

**TECHNICAL MANUAL**

**MAINTENANCE INSTRUCTIONS  
WITH ILLUSTRATED PARTS BREAKDOWN  
(DEPOT)**

**RADIO RECEIVER-TRANSMITTER,  
RT-1446/URC, P/N 10085-0000**

**THIS TECHNICAL MANUAL IS BEING PREPARED BY THE AUTOMATED TECHNICAL ORDER SYSTEM (ATOS). AS CHANGE PAGES ARE GENERATED THEY WILL REFLECT CURRENT SPECIFICATION REQUIREMENTS.**

Basic and All Changes  
Have Been Merged to  
Make This a Complete  
Publication.

**DISTRIBUTION STATEMENT B - Distribution authorized to US Government agencies only for administrative or operational use (9 September 1995). Other requests for this document shall be referred to Sacramento ALC/TILB, 3200 Peacekeeper Way, Suite 1, McClellan AFB CA 95652-1026.**

**HANDLING AND DESTRUCTION NOTICE - Handle in compliance with distribution statement and destroy by any method that will prevent disclosure of the contents or reconstruction of the document.**

Published under authority of the Secretary of the Air Force

---

**15 JANUARY 1986  
CHANGE 6 - 9 SEPTEMBER 1995**

**LIST OF EFFECTIVE PAGES**

NOTE: The portion of the text affected by the changes is indicated by a vertical line in the outer margins of the page. Changes to illustrations are indicated by miniature pointing hands. Changes to wiring diagrams are indicated by shaded areas.

**Dates of issue for original and changed pages are:**

Original ..... 0 ..... 15 Jan 86      Change ..... 5 ..... 26 Jan 95  
 Change ..... 1 ..... 27 Feb 89      Change ..... 6 ..... 9 Sep 95  
 Change ..... 2 ..... 21 Aug 89  
 Change ..... 3 ..... 13 Aug 91  
 Change ..... 4 ..... 29 May 92

**TOTAL NUMBER OF PAGES IN THIS PUBLICATION IS 485, CONSISTING OF THE FOLLOWING:**

Page No.	*Change No.	Page No.	*Change No.	Page No.	*Change No.
<b>Title</b> .....	<b>6</b>	7-84 - 7-86 .....	<b>0</b>	FP-31 .....	<b>0</b>
<b>A</b> .....	<b>6</b>	7-87 Blank .....	<b>0</b>	FP-32 Blank .....	<b>0</b>
<b>B</b> .....	<b>6</b>	7-88 - 7-110 .....	<b>0</b>	FP-33 .....	<b>0</b>
<b>C</b> Blank .....	<b>6</b>	7-111 Blank .....	<b>0</b>	FP-34 Blank .....	<b>0</b>
i - x .....	<b>0</b>	7-112 - 7-114 .....	<b>0</b>	FP-35 .....	<b>0</b>
6-1 .....	<b>0</b>	7-115 Blank .....	<b>0</b>	FP-36 Blank .....	<b>0</b>
6-2 .....	<b>3</b>	7-116 - 7-123 .....	<b>0</b>	FP-37 .....	<b>0</b>
6-3 - 6-6 .....	<b>0</b>	7-124 .....	<b>5</b>	FP-38 Blank .....	<b>0</b>
6-7 .....	<b>1</b>	7-125 - 7-160 .....	<b>0</b>	FP-39 .....	<b>0</b>
6-8 .....	<b>5</b>	8-1 - 8-2 .....	<b>0</b>	FP-40 Blank .....	<b>0</b>
6-9 - 6-12 .....	<b>0</b>	FP-1 .....	<b>0</b>	FP-41 .....	<b>0</b>
6-13 .....	<b>2</b>	FP-2 Blank .....	<b>0</b>	FP-42 Blank .....	<b>0</b>
6-14 - 6-17 .....	<b>0</b>	FP-3 .....	<b>0</b>	FP-43 .....	<b>0</b>
6-18 .....	<b>2</b>	FP-4 Blank .....	<b>0</b>	FP-44 Blank .....	<b>0</b>
6-19 - 6-76 .....	<b>0</b>	FP-5 .....	<b>0</b>	FP-45 .....	<b>0</b>
6-76.1 Added .....	<b>4</b>	FP-6 Blank .....	<b>0</b>	FP-46 Blank .....	<b>0</b>
6-76.2 Blank Added .....	<b>4</b>	<b>FP-7</b> .....	<b>6</b>	FP-47 .....	<b>0</b>
6-77 .....	<b>4</b>	<b>FP-8</b> Blank .....	<b>6</b>	FP-48 Blank .....	<b>0</b>
6-78 - 6-109 .....	<b>0</b>	FP-9 .....	<b>0</b>	FP-49 .....	<b>0</b>
6-110 Blank .....	<b>0</b>	FP-10 Blank .....	<b>0</b>	FP-50 Blank .....	<b>0</b>
7-1 - 7-13 .....	<b>0</b>	FP-11 .....	<b>0</b>	FP-51 .....	<b>0</b>
7-14 - 7-15 .....	<b>5</b>	FP-12 Blank .....	<b>0</b>	FP-52 Blank .....	<b>0</b>
7-16 .....	<b>4</b>	FP-13 .....	<b>0</b>	FP-53 .....	<b>0</b>
7-17 .....	<b>5</b>	FP-14 Blank .....	<b>0</b>	FP-54 Blank .....	<b>0</b>
7-18 .....	<b>4</b>	FP-15 .....	<b>0</b>	FP-55 .....	<b>0</b>
7-19 Blank .....	<b>0</b>	FP-16 Blank .....	<b>0</b>	FP-56 Blank .....	<b>0</b>
7-20 - 7-24 .....	<b>0</b>	FP-17 .....	<b>0</b>	FP-57 .....	<b>0</b>
7-25 .....	<b>2</b>	FP-18 Blank .....	<b>0</b>	FP-58 Blank .....	<b>0</b>
7-26 .....	<b>0</b>	FP-19 .....	<b>0</b>	FP-59 .....	<b>0</b>
7-27 .....	<b>1</b>	FP-20 Blank .....	<b>0</b>	FP-60 Blank .....	<b>0</b>
7-28 - 7-46 .....	<b>0</b>	FP-21 .....	<b>0</b>	FP-61 .....	<b>0</b>
7-47 .....	<b>2</b>	FP-22 Blank .....	<b>0</b>	FP-62 Blank .....	<b>0</b>
7-48 - 7-50 .....	<b>0</b>	FP-23 .....	<b>0</b>	FP-63 .....	<b>0</b>
7-51 Blank .....	<b>0</b>	FP-24 Blank .....	<b>0</b>	FP-64 Blank .....	<b>0</b>
7-52 - 7-64 .....	<b>0</b>	FP-25 .....	<b>0</b>	FP-65 .....	<b>0</b>
7-65 Blank .....	<b>0</b>	FP-26 Blank .....	<b>0</b>	FP-66 Blank .....	<b>0</b>
7-66 - 7-80 .....	<b>0</b>	FP-27 .....	<b>0</b>	FP-67 .....	<b>0</b>
7-81 .....	<b>2</b>	FP-28 Blank .....	<b>0</b>	FP-68 Blank .....	<b>0</b>
7-82 Blank .....	<b>2</b>	FP-29 .....	<b>0</b>	FP-69 .....	<b>0</b>
7-83 .....	<b>4</b>	FP-30 Blank .....	<b>0</b>	FP-70 Blank .....	<b>0</b>

\*Zero in this column indicates an original page



**LIST OF EFFECTIVE PAGES**

Page No.	*Change No.	Page No.	*Change No.	Page No.	*Change No.
FP-71	.....0	FP-125	.....0	FP-179	.....0
FP-72 Blank	.....0	FP-126 Blank	.....0	FP-180 Blank	.....0
FP-73	.....0	FP-127	.....0	FP-181	.....0
FP-74 Blank	.....0	FP-128 Blank	.....0	FP-182 Blank	.....0
FP-75	.....0	FP-129	.....0	FP-183	.....0
FP-76 Blank	.....0	FP-130 Blank	.....0	FP-184 Blank	.....0
FP-77	.....0	FP-131	.....0	FP-185	.....0
FP-78 Blank	.....0	FP-132 Blank	.....0	FP-186 Blank	.....0
FP-79	.....0	FP-133	.....0	FP-187	.....0
FP-80 Blank	.....0	FP-134 Blank	.....0	FP-188 Blank	.....0
FP-81	.....0	FP-135	.....0	FP-189	.....0
FP-82 Blank	.....0	FP-136 Blank	.....0	FP-190 Blank	.....0
FP-83	.....0	FP-137	.....0	FP-191	.....5
FP-84 Blank	.....0	FP-138 Blank	.....0	FP-192 Blank	.....5
FP-85	.....0	FP-139	.....0	FP-193	.....0
FP-86 Blank	.....0	FP-140 Blank	.....0	FP-194 Blank	.....0
FP-87	.....0	FP-141	.....0	FP-195	.....0
FP-88 Blank	.....0	FP-142 Blank	.....0	FP-196 Blank	.....0
FP-89	.....5	FP-143	.....0	FP-197	.....0
FP-90 Blank	.....5	FP-144 Blank	.....0	FP-198 Blank	.....0
FP-91	.....0	FP-145	.....0		
FP-92 Blank	.....0	FP-146 Blank	.....0		
FP-93	.....0	FP-147	.....0		
FP-94 Blank	.....0	FP-148 Blank	.....0		
FP-95	.....0	FP-149	.....0		
FP-96 Blank	.....0	FP-150 Blank	.....0		
FP-97	.....0	FP-151	.....0		
FP-98 Blank	.....0	FP-152 Blank	.....0		
FP-99	.....0	FP-153	.....0		
FP-100 Blank	.....0	FP-154 Blank	.....0		
FP-101	.....0	FP-155	.....0		
FP-102 Blank	.....0	FP-156 Blank	.....0		
FP-103	.....0	FP-157	.....0		
FP-104 Blank	.....0	FP-158 Blank	.....0		
FP-105	.....0	FP-159	.....0		
FP-106 Blank	.....0	FP-160 Blank	.....0		
FP-107	.....0	FP-161	.....0		
FP-108 Blank	.....0	FP-162 Blank	.....0		
FP-109	.....0	FP-163	.....0		
FP-110 Blank	.....0	FP-164 Blank	.....0		
FP-111	.....0	FP-165	.....0		
FP-112 Blank	.....0	FP-166 Blank	.....0		
FP-113	.....0	FP-167	.....0		
FP-114 Blank	.....0	FP-168 Blank	.....0		
FP-115	.....0	FP-169	.....0		
FP-116 Blank	.....0	FP-170 Blank	.....0		
FP-117	.....0	FP-171	.....0		
FP-118 Blank	.....0	FP-172 Blank	.....0		
FP-119	.....0	FP-173	.....0		
FP-120 Blank	.....0	FP-174 Blank	.....0		
FP-121	.....0	FP-175	.....0		
FP-122 Blank	.....0	FP-176 Blank	.....0		
FP-123	.....0	FP-177	.....0		
FP-124 Blank	.....0	FP-178 Blank	.....0		

\*Zero in this column indicates an original page



## SAFETY SUMMARY

The following are general safety precautions that are not related to any specific procedures and therefore do not appear elsewhere in this publication. These are recommended precautions that personnel must understand and apply during many phases of operation and maintenance.

### KEEP AWAY FROM LIVE CIRCUITS

Operating personnel must at all times observe all safety regulations. Do not replace components inside the equipment with the power supply turned on. Under certain conditions, dangerous potentials may exist when the power control is in the off position, due to charges retained by capacitors. To avoid casualties, always remove power and discharge circuits to ground before touching any circuit components. Remove watches and rings before performing any maintenance procedures.

### DO NOT SERVICE OR ADJUST ALONE

Under no circumstances should any person reach into or enter the enclosure for the purpose of servicing or adjusting the equipment except in the presence of someone who is capable of rendering aid.

### RESUSCITATION

Personnel working with or near high voltages should be familiar with modern methods of resuscitation.

Cardiopulmonary resuscitation procedures are outlined in T.O. 31-1-141-1, and annual refresher training requirements are outlined in AFOSH STD 127-50.

The following warning appears in the text in this volume, and is repeated here for emphasis.

**WARNING**

Dangerous voltages exist in this radio equipment. Before removing any covers, disconnect the primary power.

### HANDLING OF ELECTROSTATIC DISCHARGE SENSITIVE DEVICES (EDSD)

Electrostatic Discharge Sensitive Devices (EDSD) must be handled with certain precautions that must be followed to minimize the effect of static build-up. Consult T.O. 00-25-234, DOD Std-1686, and DOD HDBK 263. EDSD devices are identified in this technical order by the following symbol:



TABLE OF CONTENTS

Section/Para	Page
<b>NOTE</b>	
For chapters 1-5, see the On-Equipment Manual, T.O. 31R2-2URC-81.	
<b>CHAPTER 6. MAINTENANCE</b>	
I	INTRODUCTION
6-1.	Chapter Organization..... 6-1
II	ALIGNMENT PROCEDURES
6-2.	Introduction..... 6-2
6-3.	Alignment Procedures..... 6-3
III	DIAGNOSTIC PROCEDURES
6-4.	Depot Maintenance Philosophy..... 6-34
6-5.	Exciter PWB Assy, A1A1..... 6-34
6-6.	IF Filter PWB Assy, A1A2..... 6-38
6-7.	First Converter PWB Assy, A1A3..... 6-40
6-8.	Power Amplifier PWB Assy, A1A4A1..... 6-42
6-9.	Low Pass Filter PWB Assy, A1A5..... 6-43
6-10.	AGC PWB Assy, A1A6..... 6-45
6-11.	Receiver PWB Assy, A1A7..... 6-47
6-12.	Crystal Oscillator Assy, A1A8..... 6-66
6-13.	Reference/BFO PWB Assy, A1A9..... 6-67
6-14.	Synthesizer PWB Assy, A1A10..... 6-70
6-15.	Front Panel PWB Assy, A1A11A1..... 6-76
6-16.	Display Assy, A1A11A2..... 6-77
6-17.	Transceiver Control PWB Assy, A1A12..... 6-77
6-18.	LPA/Coupler Interface PWB Assy, A1A13..... 6-78
6-19.	Multivoltage Supply Assy, A1A14..... 6-80
6-20.	Interconnect PWB Assy, A1A15..... 6-85
6-21.	Audio Interface PWB Assy, A1A16..... 6-85
6-22.	Coupler Connector PWB Assy, A1A17..... 6-87
6-23.	AFSK Module Assy, A1A18..... 6-88
6-24.	Remote Control Interface PWB Assy, A1A19..... 6-90
6-25.	Power Supply Protection and Control PWB Assy, A2A1..... 6-92
6-26.	13.6 V Power Supply, A2A2..... 6-94
APPENDIX	..... 6-96

**TABLE OF CONTENTS (Continued)**

<b>Section/Para</b>	<b>Page</b>
<b>CHAPTER 7. ILLUSTRATED PARTS BREAKDOWN</b>	
I	INTRODUCTION
	7-1. Purpose..... 7-1
	7-2. Scope..... 7-1
	7-3. Chapter Organization..... 7-1
	7-4. Source, Maintenance, and Recoverability (SMR) Codes..... 7-1
	7-5. Federal Supply Codes for Manufacturers (FSCM)..... 7-1
II	MAINTENANCE PARTS LIST
III	NUMERICAL INDEX
IV	REFERENCE DESIGNATOR INDEX

**CHAPTER 8. FOLDOUT DRAWINGS**

LIST OF ILLUSTRATIONS

Figure		Page
CHAPTER 6. MAINTENANCE		
6-1.	Carrier Null Adjustment.....	6-4
6-2.	Exciter PWB Assy.....	6-5
6-3.	IF Filter PWB Assy.....	6-7
6-4.	First Converter PWB Assy.....	6-10
6-5.	Power Amplifier.....	6-12
6-6.	Low Pass Filter PWB Assy.....	6-14
6-7.	AGC/TGC PWB Assy.....	6-16
6-8.	Receiver PWB Assy.....	6-18
6-9.	Crystal Oscillator Assembly.....	6-20
6-10.	Reference/BFO PWB Assy.....	6-21
6-11.	Synthesizer PWB Assy.....	6-22
6-12.	Transceiver Control PWB Assy.....	6-25
6-13.	Multivoltage Supply PWB Assy.....	6-27
6-14.	Audio Interface PWB Assy.....	6-28
6-15.	AFSK Keyer/Converter PWB Assy.....	6-30
6-16.	AFSK IF Filter PSB Assy.....	6-31
6-17.	13.6 Vdc Power Supply PWB Assy.....	6-33
6-18.	AGC Flowchart.....	6-48
6-19.	TP2 and the Cathodes of CR3, CR4.....	6-75
6-20.	Composite Wave.....	6-83
6-21.	Base Signal for Q8, Q9.....	6-84

CHAPTER 7. ILLUSTRATED PARTS BREAKDOWN

7-1.	100 Watt Transceiver, RT-1446/URC, Front View.....	7-14
7-2.	100 Watt Transceiver, RT-1446/URC, Bottom Half.....	7-16
7-3.	100 Watt Transceiver, RT-1446/URC, Internal Components.....	7-20
7-4.	100 Watt Transceiver, RT-1446/URC, Front Panel Assy, A1A11.....	7-22
7-5.	100 Watt Transceiver, RT-1446/URC, Top Side View.....	7-24
7-6.	100 Watt Transceiver, RT-1446/URC, Rear View.....	7-26
7-7.	Coaxial Cables .....	7-28
7-8.	Module Assy, AFSK, A1A18.....	7-30
7-9.	Installation Kit for the 100 Watt Transceiver.....	7-32
7-10.	Non-Pendant Cable List.....	7-33
7-11.	Exciter PWB Assy, A1A1.....	7-34
7-12.	IF Filter PWB Assy, A1A2.....	7-40
7-13.	First Converter PWB Assy, A1A3.....	7-42
7-14.	Power Amplifier Assy, A1A4.....	7-46
7-15.	Power Amplifier PWB Assy, A1A4A1.....	7-48
7-16.	Low Pass Filter PWB Assy, A1A5.....	7-52
7-17.	AGC/TGC PWB Assy, A1A6.....	7-56
7-18.	Receiver PWB Assy, A1A7.....	7-60
7-19.	Crystal Oscillator Assy, A1A8.....	7-66
7-20.	Reference/BFO PWB Assy, A1A9.....	7-68
7-21.	Synthesizer PWB Assy, A1A10.....	7-72
7-22.	VCO PWB Assy, A1A10A1.....	7-76
7-23.	Front Panel PWB Assy, A1A11A1.....	7-78

## LIST OF ILLUSTRATIONS (Continued)

Figure		Page
7-24.	Display Assy, A1A11A2.....	7-82
7-25.	Transceiver Control PWB Assy A1A12.....	7-84
7-26.	LPA/Coupler Interface PWB Assy, A1A13.....	7-88
7-27.	Multivoltage Supply Assy, A1A14.....	7-90
7-28.	Multivoltage Supply PWB Assy, A1A14A1.....	7-92
7-29.	Interconnect PWB Assy, A1A15.....	7-96
7-30.	Audio Interface PWB Assy, A1A16.....	7-98
7-31.	Coupler Connector PWB Assy, A1A17.....	7-100
7-32.	AFSK Keyer/Converter PWB Assy, A1A18A1.....	7-102
7-33.	AFSK IF Filter PWB Assy, A1A18A2.....	7-106
7-34.	Power Supply Protection and Control PWB Assy, A2A1.....	7-108
7-35.	13.6 V Power Supply, A2A2.....	7-112
7-36.	13.6 V Power Supply PWB Assy, A2A2A1.....	7-116

## CHAPTER 8. FOLDOUT DRAWINGS

FO-1	Family Tree 100 Watt Transceiver.....	FP-1
FO-2	Transceiver Assy, A1, Interconnection Diagram.....	FP-3
FO-3	Exciter PWB Assy, A1A1.....	FP-29
FO-4	IF Filter PWB Assy, A1A2.....	FP-51
FO-5	First Converter PWB Assy, A1A3.....	FP-53
FO-6	Power Amplifier PWB Assy, A1A4A1.....	FP-57
FO-7	Low Pass Filter PWB Assy, A1A5.....	FP-61
FO-8	AGC/TGC PWB Assy, A1A6.....	FP-69
FO-9	Receiver PWB Assy, A1A7.....	FP-87
FO-10	REF/BFO PWB Assy, A1A9.....	FP-103
FO-11	Synthesizer PWB Assy, A1A10.....	FP-115
FO-12	Front Panel Assy, A1A11.....	FP-129
FO-13	Front Panel Assy, A1A11A1.....	FP-131
FO-14	Display Assy, A1A11A2.....	FP-135
FO-15	Transceiver Control PWB Assy, A1A12.....	FP-141
FO-16	LPA/Coupler Interface PWB Assy, A1A13.....	FP-159
FO-17	Multivoltage Supply PWB Assy, A1A14A1.....	FP-167
FO-18	Interconnect PWB Assy, A1A15.....	FP-171
FO-19	Audio Interface PWB Assy, A1A16.....	FP-177
FO-20	Coupler Connector PWB Assy, A1A17.....	FP-179
FO-21	AFSK Module Assy, A1A18.....	FP-181
FO-22	Power Supply Assy, A2, Interconnection Diagram.....	FP-193
FO-23	Power Supply Protection and Control PWB Assy, A2A1.....	FP-195
FO-24	13.6V Power Supply Assy, A2A2.....	FP-197

LIST OF TABLES

Table		Page
6-1	Test Equipment.....	6-2



## GLOSSARY

A	Ampere(s)
A/D	Analog-to-Digital (Converter)
AFSK	Audio frequency shift keying; a baseband modulation scheme in which two audio frequencies are used to represent binary coded data; the frequency is shifted to one frequency to represent a 1 (mark) and to the other to represent a 0 (space).
AGC	Automatic gain control
ALE	Address latch enable
AM	Amplitude modulation; a modulation scheme in which the carrier is made to vary in amplitude in accordance with the modulating signal.
AME	Amplitude modulation equivalent
ANTIVOX	Prevents false VOX operation; see VOX
BFO	Beat Frequency Oscillator, used in SSB detection circuits
BIT	Built-in Test
BIU	Bus interface unit
BW	Bandwidth
CPU	Central processing unit
CREV	Converter reverse
CW	Continuous wave; a wave that does not vary in amplitude or frequency and is turned on and off to carry intelligence, e.g., Morse Code
D/A	Digital-to-Analog (Converter)
dB	Decibel(s)
dBm	Decibel(s) relative to one milliwatt
EMI	Electromagnetic interference
EPROM	Erasable programmable read-only memory
EU	Execution unit
HF	High frequency; a radio frequency band extending from about 3 MHz to 30 MHz; in this manual, HF includes 1.6 to 30 MHz.
HV	High voltage
IF	Intermediate frequency
IM	Intermodulation (distortion)
I/O	Input/Output
KREV	Keyer reverse
LCD	Liquid crystal display
LED	Light emitting diode
LPA	Linear power amplifier
LSB	Lower sideband; a modulation scheme in which the intelligence is carried on the first sideband below the carrier frequency; see SSB
MIC	Microphone
mA	Milliampere(s)
mV	Millivolt(s)
NBSV	Narrow band secure voice
PEP	Peak envelope power
PPC	Peak power control
PWB	Printed wiring board
RAM	Random access memory
rms	Root mean square
RTC	Real time clock
RX	Receive

**GLOSSARY (Continued)**

S TONE	Sidetone
SSB	Single sideband; a modulation scheme in which the intelligence is carried by one of the carrier sidebands, the other sideband and the carrier center frequency being suppressed
TGC	Transmitter gain control
TX	Transmit
uA	Microampere(s)
uP	Microprocessor
USB	Upper sideband; a modulation scheme in which the intelligence is carried on the first sideband above the carrier frequency; see SSB
uV	Microvolt(s)
Vac	Volts, alternating current
VCO	Voltage controlled oscillator
Vdc	Volts, direct current
VOX	Voice operated transmission
VSWR	Voltage standing wave ratio; the ratio of the maximum to the minimum voltage of a standing wave on a radio frequency transmission line
W	Watt(s)

## INTRODUCTION

The purpose of this manual is to provide information necessary for the depot-level maintenance of Receiver-Transmitter, Radio, RT-1446/URC, manufactured by the RF Communications Group of Harris Corporation, Rochester, New York. The manual is divided into three chapters. The contents of each chapter are briefly described in the following paragraphs.

### NOTE

This manual only contains three chapters, because chapters 1-5 are contained in the On-Equipment Manual, T.O. 31R2-2URC-81. For a description of the contents of these chapters, see the INTRODUCTION in T.O. 31R2-2URC-81.

Chapter 6 describes the depot-level maintenance procedures. The maintenance procedures in this chapter are based on performance testing and trouble analysis of the subassembly or PWB to locate and replace faulty parts at the lowest replaceable unit level (LRU).

Chapter 7 contains the Illustrated Parts Breakdown (IPB) information at the depot level. This includes assemblies and parts that may be replaced at the depot location.

Chapter 8 contains foldout (FO) drawings, which consist of the schematic diagrams for all the PWB assemblies. A cross reference list is also provided. The diagrams are numbered FO-1, FO-2, etc. They are printed on sheets with page-size blank aprons to permit viewing the diagram with the rest of the book closed or opened to another page.

The following specifications, standards, and publications were used in the preparation of this manual.

**APPLICABLE SPECIFICATIONS**

<b>SPECIFICATION</b>	<b>NAME</b>
MIL-M-38798B, para. 3.4	Combined Operation and Maintenance Instructions Manual (Equipment).
MIL-M-38807, Amend. 4	Preparation of Illustrated Parts Breakdown.
MIL-M-38790 and MIL-M-38784A	General Requirements for Preparation of Technical Manuals.

**APPLICABLE STANDARDS**

<b>STANDARD</b>	<b>NAME</b>
MIL-STD-12	Abbreviations for use on Drawings and in Technical Type Publications.
MIL-STD-15-1A	Graphic Symbols for Electrical Components.
MIL-STD-17-1	Mechanical Symbols.
MIL-STD-806	Graphic Symbols for Logic Diagrams.

**APPLICABLE PUBLICATIONS**

<b>PUBLICATION</b>	<b>NAME</b>
DOD 5200.20	Distribution Statements on Technical Documents.
USAS Y14.15-1966	Electrical and Electronic Diagrams.
USAS Y32.16-1968	Electrical and Electronic Reference Designations.
T.O. 31-1-141 (Series)	Technical Manual-Basic Electronic Technology and Testing Practices.

**CHAPTER 6****MAINTENANCE**

---

**WARNING**

Dangerous voltages exist in this radio equipment. Before removing any covers, disconnect the primary power.

**Section I. INTRODUCTION**

**6-1. CHAPTER ORGANIZATION.** This chapter is divided into three sections. Section I tells how the chapter is organized. Section II contains alignment procedures for the replaceable modules. This information is also contained in the On-Equipment Manual, T.O. 31R2-2URC-81 , and is repeated here for convenience. Section III consists

of diagnostic procedures which will enable you to troubleshoot faulty modules to the component level. These procedures are based on use of the BIT feature. For more information on BIT, as well as removal/replacement procedures and periodic maintenance procedures, see the On-Equipment Manual, T.O. 31R2-2URC-81.

## Section II. ALIGNMENT PROCEDURES

**6-2. INTRODUCTION.** This section contains instructions for checking and adjusting the replaceable subassemblies in the 100 Watt Transceiver. This section also contains circuit board

layouts to help you identify the components that can be adjusted. To do the procedures described in this section, you need the test equipment listed in Table 6-1 or equivalents.

Table 6-1. Test Equipment\*

Generic Name	Military Designation	Manufacturer, Model No.	National Stock No.	Required Range
Oscilloscope	AN/USM-425 (V) 1	Tektronix, Model 465m	6625-01-032-6914	5 mV to 200 V AC or DC; DC to 100 MHz
Signal Generator (RF)	SG-1093/U	Hewlett Packard, Model 8640B	6625-00-318-6304	-120 to +20 dBm, 440 KHz to 70.5 MHz in 10 Hz increments
Signal Generator (audio)		Hewlett Packard, Model 204D	6625-00-427-4513	-70 to +10 dBm; 300 Hz to 3.3 KHz
Electronic Voltmeter w/ AC Probe & T-connector		Hewlett Packard, Model 410C	6625-00-469-2258	10 to 100 V rms; 1.6 to 30 MHz (peak reading)
AC Voltmeter		Model 11036A	6625-00-910-5973	
		Model 11042A	5985-00-713-4356	
Digital Multimeter		Hewlett Packard, Model 400F	6625-00-403-6526	300 uV to 3 V (audio frequency)
		Fluke, Model 8012A	6625-01-140-0221	200 mV to 250 Vac; 200 mV to 40 Vdc; 0 to 20 megohms
Microprocessor, Adapter	9000A-8088	Fluke	6625-01-210-7865	
Spectrum Analyzers		Textronix Model 496 or Model 492	6625-01-156-6760 6625-01-074-2550	-70 to +20 dBm; 455 KHz to 70.5 MHz
10:1 Probe (for oscilloscope)		Hewlett Packard, Model 10080A		Input impedance: 1 megohm
10 dB Pad		Texscan, Model FP-50-10	5985-01-089-3229	

\* NOTE: Equivalent Items Authorized

Table 6-1. Test Equipment (continued)

Generic Name	Military Designation	Manufacturer, Model No.	National Stock No.	Required Range
In-Line fuse	MX-1730/U	Hewlett Packard, Model 11509A	5920-00-636-0679	DC-480 MHz
Frequency Counter*		Hewlett Packard, Model 5335A	6625-01-099-8151	Calibrate 10 MHz to within 1 part in $10^9$
DC Power Supply		Raytheon, Model DCR40-70B	6130-01-136-3142	28 Vdc at 15 A; 13.6 Vdc at 30 A
Dummy Load		Bird, Model 8833	6625-00-225-9074	100 W, 50 ohms
Wattmeter	AN/USM-298	Bird, Model 43	6625-00-880-5119	100 W, 50 ohms
PROM Programmer		Data I/O, Model System 19	7045-01-115-8993	
DC Milli-ammeter		Hewlett Packard, Model HP 4288		0 - 500 mA, DC
Inductive Current Probe	ME-488/U	Hewlett Packard, Model HP428B	6625-00-816-9324	0 - 500 mA, DC
100 Watt Transceiver	RT-1446/URC	RF Communications Model RF-350K	5820-01-162-3402	
AFSK Option		RF Communications Model RF-358	5820-01-174-7219	
Remote Control Interface Board		RF Communications P/N 10088-6000	5820-01-162-1112	

\* Must be connected to an external frequency standard with a stability of at least 1 part in  $10^9$  per day.

### 6-3. ALIGNMENT PROCEDURES.

#### NOTE

After each of the following alignments, disconnect test equipment and reconfigure equipment (module or circuit card) to normal operating condition.

#### NOTE

Disconnect LPA, antenna coupler, and remote control unit before performing alignments. Connect transceiver to dummy load.

#### a. EXCITER PWB ASSY., A1A1 (figure 6-2)

(1) **R110/R117, Carrier Null Adjustments**

(a) Disconnect A1A7J3 from P1. Connect a spectrum analyzer to P1, with setup as follows:

- Input Attn.....20 DB
- Scan Width.....0.5 KHZ/Div.
- Band Width.....0.1 KHZ
- Scan Time/Div..... 0.1 Sec
- Log Ref Level.....-30 dBm
- Scan Trigger.....Auto
- Scan Mode.....Int
- Video Fltr.....Off
- Log/Linear..... 10 DB Log

**NOTE**

It may be necessary to start at a higher scan width to find the desired signal initially.

(b) Key the transceiver in CW mode with the CW key.

(c) You should see a signal something like figure 6-1.

(d) Adjust R110 and R117 for a minimum carrier level (at least 40 dB down from sidetones).

**NOTE**

THE ILLUSTRATION BELOW ASSUMES THAT SWITCH S1 ON IF FILTER PWB A1A2 IS IN THE UPPER SIDE BAND POSITION (U). IF S1 IS IN THE LOWER SIDE BAND POSITION (L), THE FREQUENCIES SHOWN WILL BE SHIFTED DOWNWARD BY 2 KHZ.

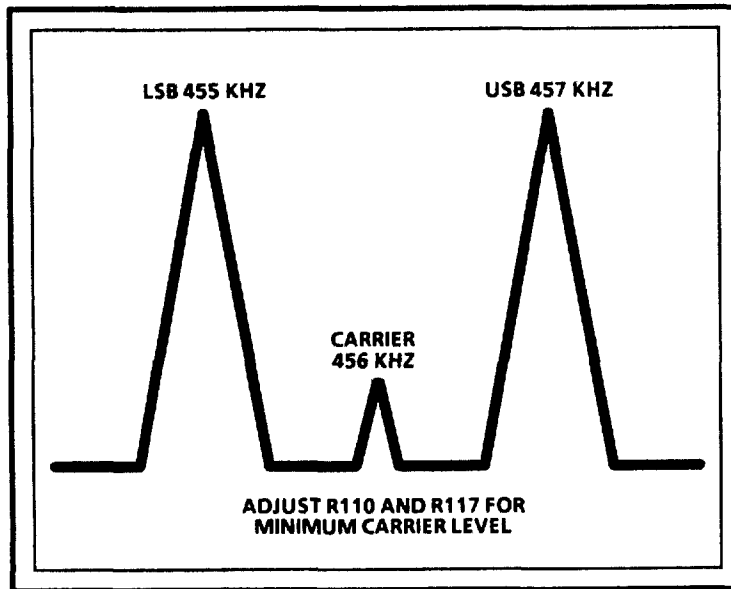

\*350-074

Figure 6-1. Carrier Null Adjustment



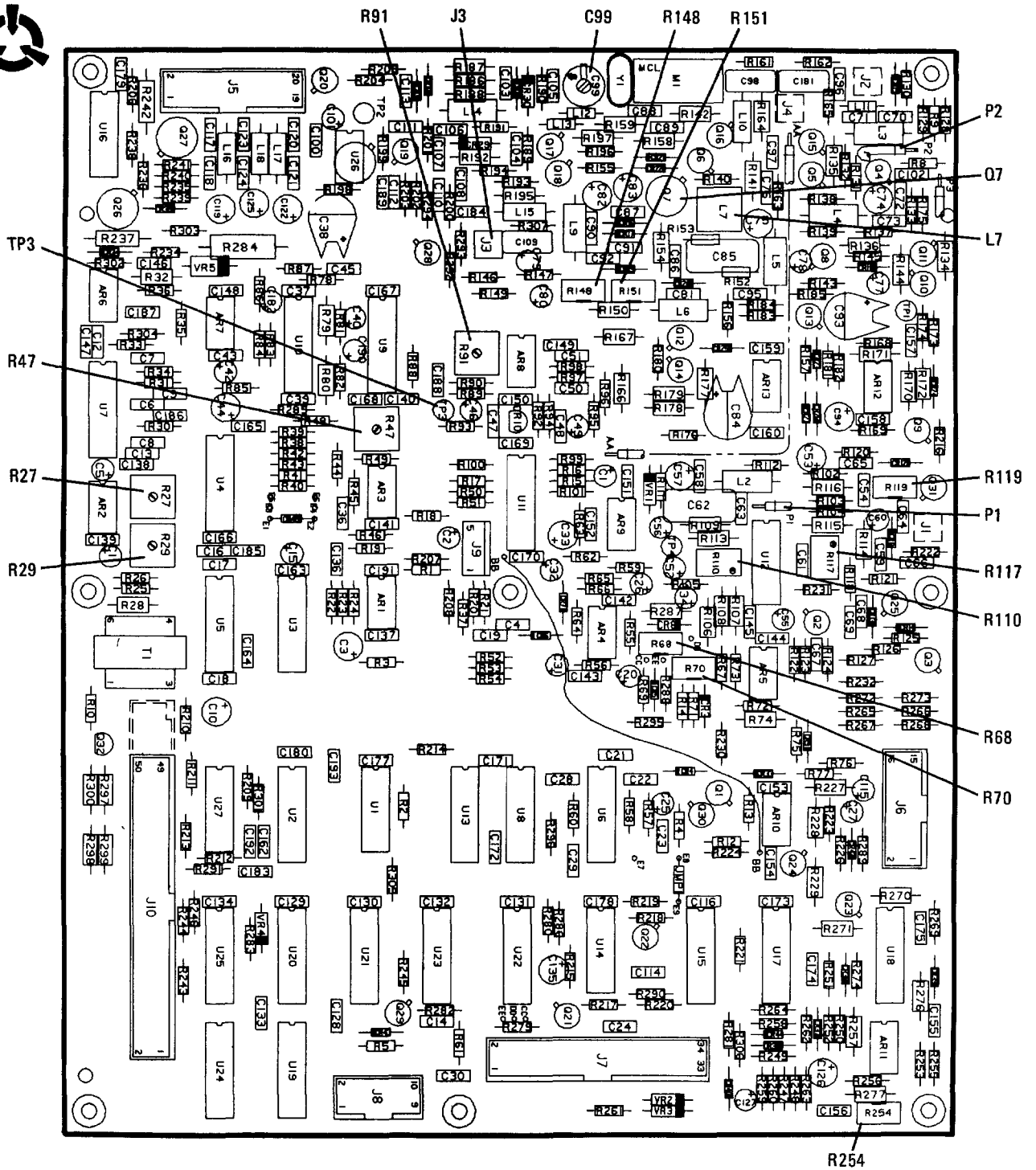

350-076A

Figure 6-2. Exciter PWB Assy

**(2) L7, 455 KHZ Presence Det Peaking Adj.**

- (a) Using a signal generator, inject an unmodulated 455 KHz, -28 dBm signal into P2.
- (b) Connect J3 to a 50 ohm dummy load.
- (c) Observe the collector of Q7 with an oscilloscope.
- (d) Adjust L7 for the peak signal on the oscilloscope.

**(3) R119, AME Inserted Carrier Level Adjustment**

- (a) Connect J1 (RF in/out) of the transceiver to a wattmeter and 50 ohm dummy load.
- (b) Key the transceiver in AME mode with no modulation.
- (c) Adjust R119 for a level of 25 watts on the wattmeter.

**(4) R148, Tune Power Adjustment**

- (a) Connect an antenna coupler to the transceiver with an antenna coupler control cable.
- (b) Connect J1 (RF in/out) of the transceiver to a wattmeter and 50 ohm dummy load.
- (c) Key the transceiver.
- (d) Adjust R148 for 35 watts, as indicated on the meter.

**NOTE**

Performing this adjustment causes the tune power to lock up. After completing the adjustment, turn the transceiver off and on again to reset the tune power flag.

**(5) C99, Bandstop Filter Adjustment**

- (a) Connect a spectrum analyzer to J3, with a 10 dB attenuator pad between the analyzer and J3. Setup as follows:
  - Input Attn.....50 DB
  - Scan Width.....0.5 KHZ/Div.
  - Band Width.....0.3 KHZ
  - Scan Time/Div.....50 msec
  - Log Ref Level.....+10 dBm
  - Scan Trigger.....Auto
  - Scan Mode.....Int
  - Video Fltr.....Off
  - Log/Linear..... 10 DB Log

**NOTE**

It may be necessary to start at a higher scan width to find the desired signal initially.

- (b) Using a signal generator, inject an unmodulated 454 KHz signal at -18 dBm into P2.
- (c) Key the transceiver, and observe the signal on the spectrum analyzer. 40.454 MHz signal will be observed.
- (d) Adjust C99 for maximum signal strength, as indicated on the analyzer.

**(6) R254, Low Power Threshold Adjustment.**

- (a) Select AME mode on the transceiver front panel.
- (b) Disconnect the cable from J4 on the First Converter PWB Assy.
- (c) Connect a signal generator to this cable (color coded yellow).
- (d) Set the signal generator for the frequency selected on the transceiver front panel. Set the output level to -20 dBm, with a modulating tone of 1 KHz at 30% modulation.
- (e) Key the transceiver with the 2ND, TX KEY buttons on the front panel. Set meter to FWD.

(f) Adjust the signal generator level so that the output power of the transceiver is 50 W, as indicated on the front panel meter.

(g) Adjust R254 so that the LOW PWR Indicator just comes on.

**(7) R47, Audio Meter Calibration Adjustment.**

(a) Select the AUDIO meter on the transceiver front panel.

(b) Select CW mode.

(c) Key the transceiver with the CW key, and adjust R47 for 0 dB on the meter.

**(8) R27 (LINE) and R29 (AUDIO 2), Levelling Adjustments.**

These potentiometers are used to compensate for varying input levels in these signals. Adjust them as follows:

(a) For AUDIO 2, inject a 1 KHz signal at +10 dBm into J4, pins 4 and 5, at the rear of the transceiver. For LINE, connect the Remote Control Unit's control cable into J9 at the rear of the transceiver.

(b) For AUDIO 2, select AUDIO 2 as the audio source on the transceiver front panel. For LINE, select REMOTE operation and audio source of MIC on the transceiver front panel.

(c) Select the AUDIO meter on the transceiver front panel (for AUDIO 2) or on the Remote Control Unit (for LINE).

(d) Key the transceiver, and adjust R29 (AUDIO 2) or R27 (LINE) for an indication of 0 on the transceiver meter. (For the LINE adjustment, you will have to talk into the microphone on the Remote Control Unit.)

**(9) R68 (VOX) and R70 (CW), Delay Adjustments**

These potentiometers set the "hang time" for VOX and CW keying; that is, they determine the amount of time it takes for the transceiver to unkey. These adjustments are preferential, but the normal factory setting is 1/2 to 3/4 second for VOX voice and 1 second for CW.

(a) To adjust R68 select CW mode and connect a CW key, estimate the elapsed time before the transceiver unkeys. Adjust R68 until the desired time delay is achieved.

(b) Select USB mode and VOX voice. Using MIC as the AUDIO SOURCE, adjust R70 so that the end of a test count, the desired time elapses before the transceiver unkeys.

**(10) R91, Clipper Level Adjustment.**

This adjustment is preferential. The range is from 0 dB (no clipping, R91 fully counterclockwise) to 12 dB (maximum clipping, R91 fully clockwise), with the normal factory setting at 6dB. To obtain this factory setting, do the following.

**NOTE**

A close approximation to the following adjustment can be obtained by simply setting R91 to the center of its turning range.

(a) Select CLIP on the transceiver.

(b) Connect an oscilloscope to TP3 on the Exciter PWB Assy.

(c) Connect an audio signal generator to PATCH IN on the rear panel terminal strip of the transceiver.

(d) Select PATCH as the AUDIO SOURCE on the transceiver. (Make sure that the Audio Interface PWB Assy is set for 4-wire PATCH.)

- (e) Turn R91 fully counterclockwise.
- (f) Set the signal generator frequency to 1 KHz. Adjust the signal generator level for a 1V pk-pk signal on the oscilloscope. Oscilloscope is still connected to TP3.
- (g) Turn R91 clockwise until the signal on the oscilloscope increases to 2 V pk-pk.

b. IF FILTER PWB ASSY., A1A2 (figure 6-3)

- (1) L2, 455 KHZ Fltr Input Adj.
  - (a) Select USB mode on the transceiver.
  - (b) Connect a spectrum analyzer to J2 on the IF Filter PWB Assy. and setup as follows:

- Input Attn..... 0 DB
- Scan Width ..... 1 KHZ/Div.
- Band Width..... 0.3 KHZ
- Scan Time/Div ..... 50 msec
- Log Ref Level..... -40 dBm
- Scan Trigger ..... Auto
- Scan Mode..... Int
- Video Fltr ..... Off
- Log/Linear..... 10 DB Log

**NOTE**

It may be necessary to start at a higher scan width to find the desired signal initially.

- (c) Connect a signal generator to J1 on the IF Filter PWB Assy, and inject a 454 KHz test signal at -60 dBm.
  - (d) Adjust L2 for peak output at J2.
- (2) R5, IF Gain Adjustment.

Using the hookup in the above procedure, adjust R5 for an amplitude of -43 dBm (17 dB gain over the input at J1) on the spectrum analyzer.

c. FIRST CONVERTER PWB ASSY A1A3 (figure 6-4).

- (1) L7 - L9, Low Pass Filter Adjustment.
  - (a) Inject a -20 dBm signal into J1 at 59.3 MHz. Unsolder JMP1.

- (b) Connect a spectrum analyzer to J7, pin 1 with a 50 ohm probe, and setup as follows:

- Input Attn..... 0 DB
- Scan Width ..... 0.5 KHZ/Div.
- Band Width..... 0.3 KHZ
- Scan Time/Div ..... 50 msec
- Log Ref Level..... -60 dBm
- Scan Trigger ..... Auto
- Scan Mode..... Int
- Video Fltr ..... Off
- Log/Linear..... 10 DB Log

**NOTE**

It may be necessary to start at a higher scan width to find the desired signal initially.

- (c) Adjust L7 for a null (minimum signal indication) at 59.3 MHz.
  - (d) Change the signal generator frequency to 40.455 MHz.
  - (e) Adjust L8 for a null at this frequency.
  - (f) Change the signal generator frequency to 44.0 MHz.
  - (g) Adjust L9 for a null at 44.0 MHz.
  - (h) Resolder JMP1.
- (2) L17, and L14, 40 MHZ IF Fltr Peaking/Adj.
- (a) Inject a -20 dBm signal into J1 at the transceiver's operating frequency.
  - (b) Connect a spectrum analyzer to J2 and setup as follows:

- Input Attn..... 40 DB
- Scan Width ..... 0.5 KHZ/Div.
- Band Width..... 0.3 KHZ
- Scan Time/Div ..... 50 msec
- Log Ref Level..... 0 dBm
- Scan Trigger ..... Auto
- Scan Mode..... Int

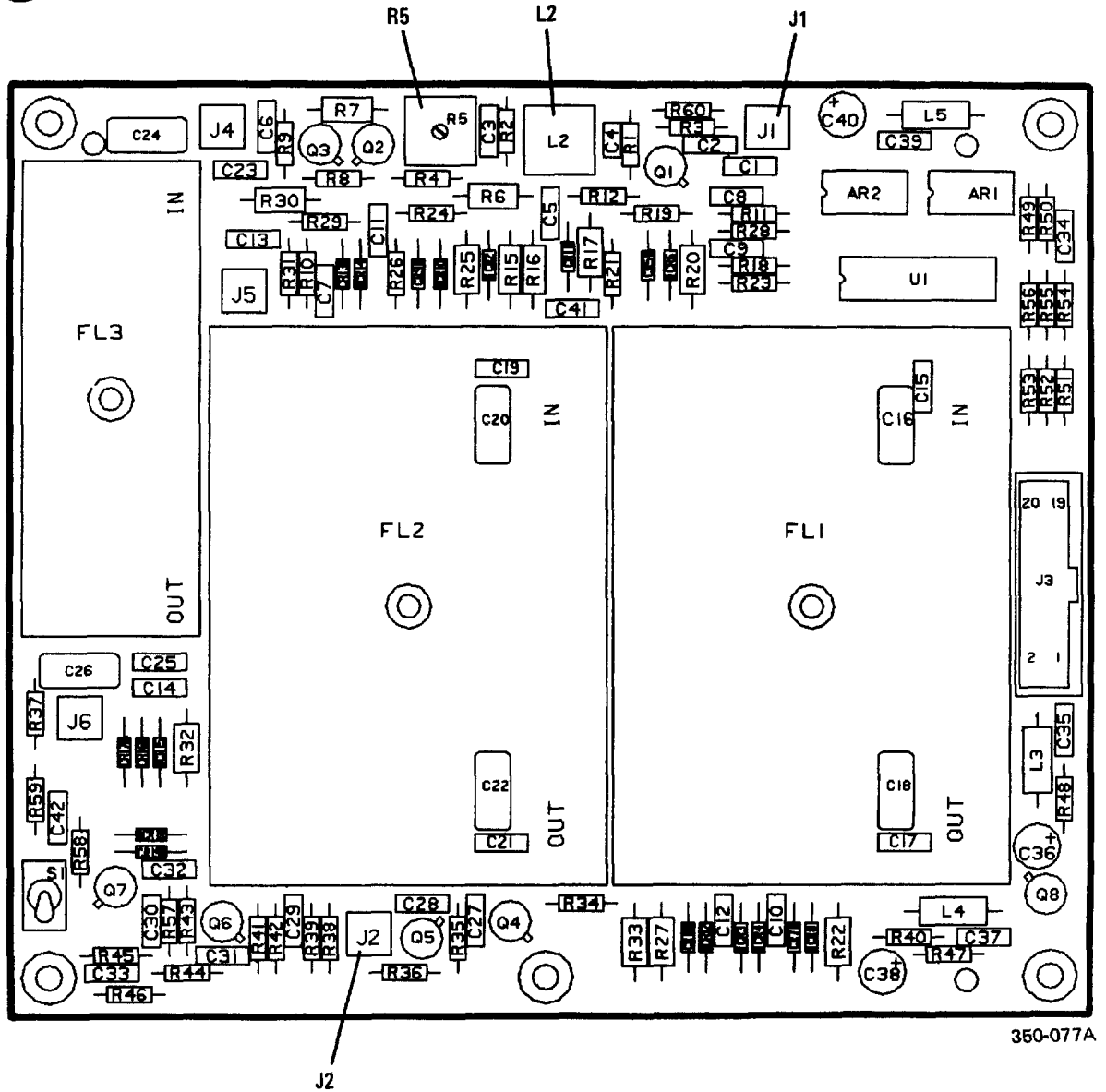

Figure 6-3. IF Filter PWB Assy

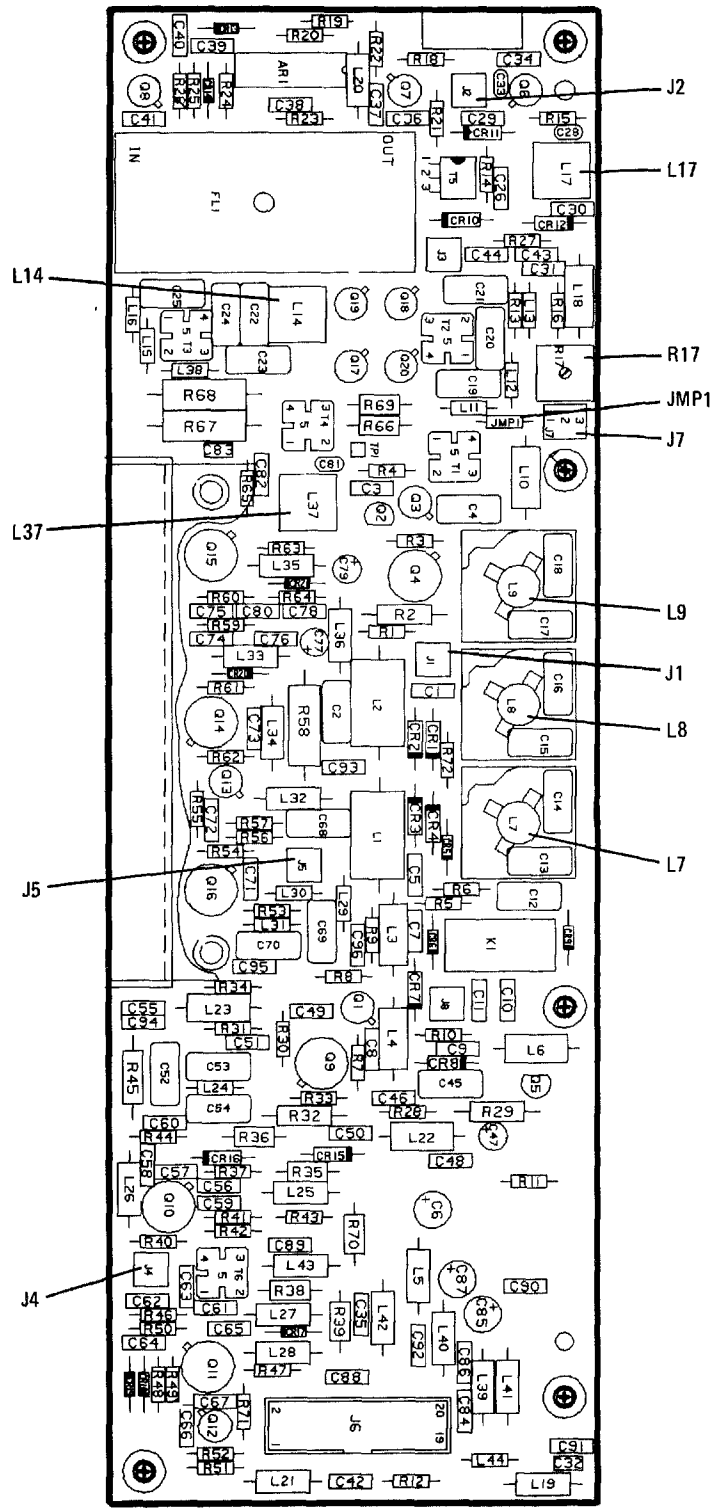

Figure 6-4. First Converter PWB Assy

- Video Filtr..... Off
- Log/Linear..... 10 DB Log

**NOTE**

It may be necessary to start at a higher scan width to find the desired signal initially.

- (c) Adjust L17 and L14 for maximum level at 40.455 MHz on the spectrum analyzer.

**(3) R17, AGC Adjustment**

- (a) Select AGC: OFF on the front panel of the transceiver.
- (b) Set the RF GAIN control on the front panel fully clockwise.
- (c) Connect a spectrum analyzer to J2. Setup as follows:

- Input Attn.....40 DB
- Scan Width.....0.5 KHZ/Div.
- Band Width..... 0.3 KHZ
- Scan Time/Div..... 50 msec
- Log Ref Level.....0 dBm
- Scan Trigger.....Auto
- Scan Mode.....Int
- Video Filtr..... Off
- Log/Linear..... 10 DB Log

**NOTE**

It may be necessary to start at a higher scan width to find the desired signal initially.

- (d) Inject a -30 dBm signal at the operating frequency into J1 (RF in/out) on the back of the transceiver.
- (e) Observe the level of the 40.455 MHz signal on the analyzer.
- (f) Rotate the RF GAIN control fully counterclockwise.
- (g) Adjust R17 so that the signal on the analyzer is 20 dB less than it was when the RF GAIN control was fully clockwise.

**(4) L37, 40 MHZ If Trap Adj.**

- (a) Inject a 0 dBm signal at 40.455 MHz into J5.

- (b) Connect a spectrum analyzer to J2. Setup as follows:

- Input Attn.....40 DB
- Scan Width.....0.5 KHZ/Div.
- Band Width..... 0.3 KHZ
- Scan Time/Div..... 50 msec
- Log Ref Level.....0 dBm
- Scan Trigger.....Auto
- Scan Mode.....Int
- Video Filtr..... Off
- Log/Linear..... 10 DB Log

**NOTE**

It may be necessary to start at a higher scan width to find the desired signal initially.

- (c) With no signal coming in at J1, adjust L37 for minimum signal indication on the spectrum analyzer at 40.455 MHz.

d. POWER AMPLIFIER A1A4 (figure 6-5).

**NOTE**

Disconnect P1 for all of the power amplifier procedures.

Power-on Checkout and Alignment Procedure.

**(1) R1 and R4, Bias Current Adjustment**

- (a) Disconnect internal connections to E17 and E13. Connect external DC power supply (13.6 V at 30 A) to E13 (13.6 V) and E17 (GND) on the Power Amplifier Board.

**CAUTION**

Insulate internal connections to E13.

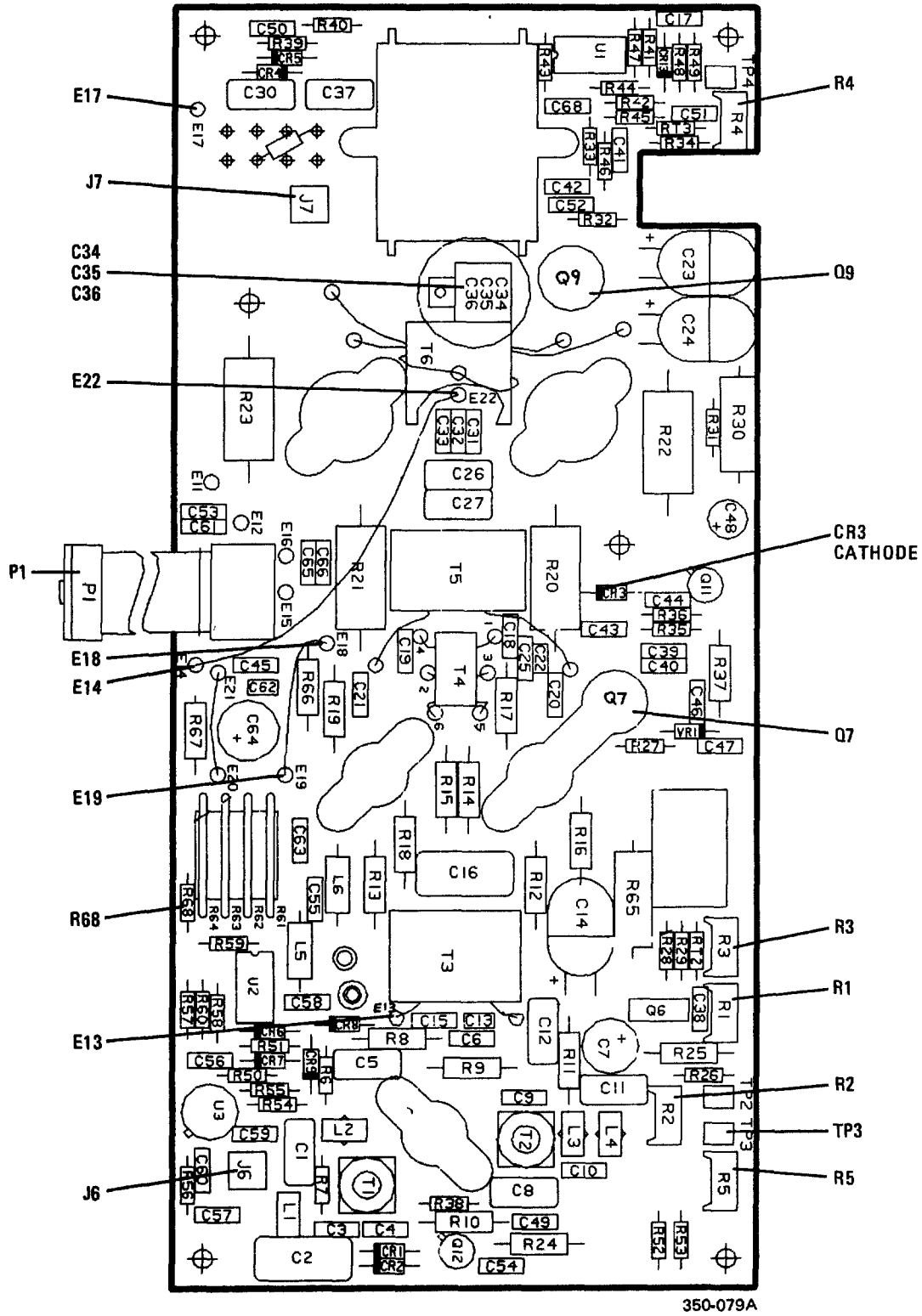

Figure 6-5. Power Amplifier PWB



- (b) Using an HP4288 DC milliammeter with an HP428B inductive current probe, connect the probe to the 14 AWG wire between E14 and E22.
- (c) Using a jumper wire, place a ground on cathode of CR3. This keys the Power Amplifier.
- (d) Adjust R4 for 300 mA on the meter (R4 and R3 are very sensitive adjustments).
- (e) Connect the probe to the 18 AWG wire between E18 and E19, and adjust R3 for 110 mA on the meter.
- (f) Connect a DC voltmeter to TP3, and adjust R1 for 0.4 Vdc on the meter.

## (2) Gain Slope Adjustment

- (a) Using an SMB to BNC adapter, connect an RF signal generator to the RF input connector J6 on the Power Amplifier Board.
- (b) Using a BNC to SMB adapter, connect the RF output connector J7 to a wattmeter and 50 ohm dummy load.
- (c) Set the output frequency of the signal generator to 30 MHz.
- (d) Adjust the RF output level of the signal generator for an output power indication of 100 watts on the wattmeter. The output power of the signal generator required to do this should not be more than approximately +12 dBm.
- (e) Without changing the power output, adjust the frequency of signal generator to 1.6 MHz.
- (f) Adjust R2 for an indication of 100 watts on the wattmeter.

## (3) Current Limit Adjustment

### CAUTION

Turn off the signal generator and allow the Power Amplifier to cool down for a few minutes before doing this part of the procedure.

- (a) Turn the signal generator back on, using the test setup of the previous section.

### CAUTION

You will be overdriving the Power Amplifier for a brief period in order to perform the current limit adjustment. Do not overdrive the Power Amplifier for more than 10 seconds.

- (b) Connect a DC voltmeter to the end of R68 that is closer to the ribbon cable connector.
- (c) With the signal generator frequency at 1.6 MHz, increase the RF output power until the current meter on the DC power supply indicates 24 A.
- (d) Adjust R5 for +5.0 Vdc on the voltmeter.
- (e) Turn off the signal generator and allow the Power Amplifier to cool down for a few minutes.

### NOTE

Reconnect P1 after completing power amplifier alignment procedures.

## e. LOW PASS FILTER PWB ASSY A1A5 (figure 6-6)

### (1) C1, Frequency Adjustment; R1, Level Adjustment

- (a) On J7, place the jumper in the test position (pin 2 to pin 3).

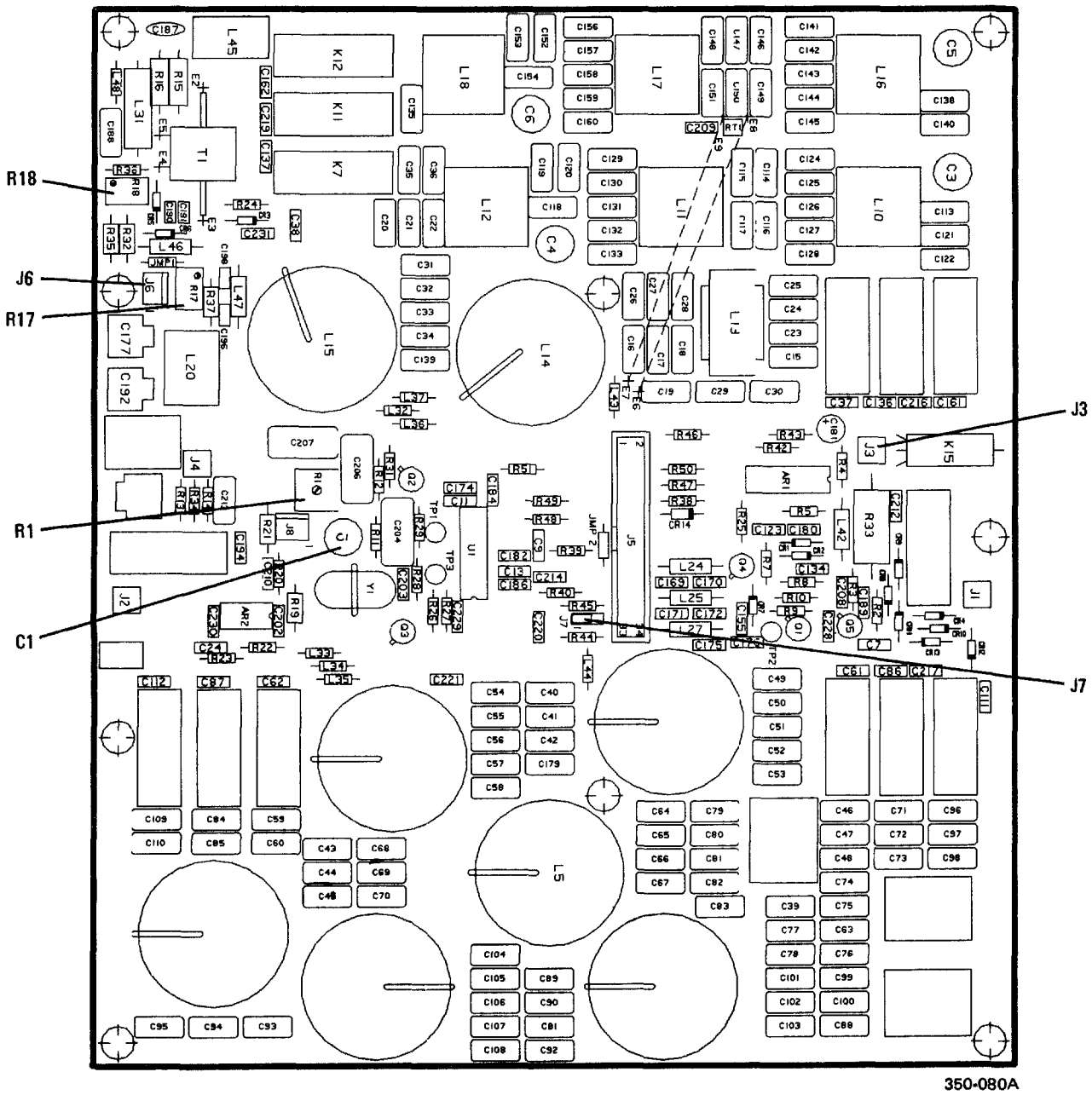

Figure 6-6. Low Pass Filter PWB Assy

- (b) Connect a frequency counter to J3, and use C1 to adjust the frequency on the counter to 2.45760 MHz.
- (c) Disconnect the frequency counter from J3, and connect a spectrum analyzer in its place. Setup as follows:
  - Input Attn.....40 DB
  - Scan Width.....0.5 KHZ/Div.
  - Band Width..... 0.3 KHZ
  - Scan Time/Div..... 50 msec
  - Log Ref Level.....0 dBm
  - Scan Trigger.....Auto
  - Scan Mode.....Int
  - Video Fitr.....Off
  - Log/Linear..... 10 DB Log

**NOTE**

It may be necessary to start at a higher scan width to find the desired signal initially.

- (d) Adjust R1 for -18 dBm at 2.4576 MHz on the spectrum analyzer.
- (e) On J7, place jumper (PN65474-001) in the normal position (pin 1 to 2).

**) R17 and R18, Forward and Reflected Power Adjustments**

- (a) Disconnect the RF input to the Power Amplifier at J6 on the Power Amplifier PWB.
- (b) Connect an RF signal generator to the Power Amplifier at J6.
- (c) Connect the output of the 100 Watt Transceiver (J1) to an RF wattmeter (50 ohms) and dummy load.
- (d) Adjust the frequency of the signal generator to 15 MHz.
- (e) Select USB on the transceiver and key the mike.
- (f) Adjust the output level of the signal generator for 100 W on the wattmeter.

- (g) Connect a DC voltmeter to J6-1 on the Low Pass Filter PWB Assy.
- (h) Adjust R18 for a null (minimum voltage) on the voltmeter. Null can be negative; if so, adjust for maximum negative voltage.
- (i) Connect the voltmeter to J6-2.
- (j) Adjust R17 for +8.0 ±05 Vdc.

f. AGC/TGC PWB ASSY A1A6 (figure 6-7).

**(1) R167, AGC Threshold Adjustment**

- (a) Inject a 15.001 MHz, -103 dBm signal at the antenna jack J1 on the transceiver. Set AGC to MED.
- (b) Set the transceiver for a frequency of 15.000 MHz USB.
- (c) Verify that a 1 KHz tone is audible.
- (d) Connect a multimeter to TP11, and adjust R167 for 0 (±0.1) Vdc on the meter

**(2) R119, TGC Clock Frequency Adjustment**

- (a) Connect a frequency counter to TP6.
- (b) Power up the transceiver and adjust R119 for 32.768 KHz ±800 Hz as indicated on the frequency counter.

**(3) R37, 100 Watt Set Point Adjustment.**

- (a) Turn R37 fully counterclockwise.
- (b) Power up the transceiver and set the frequency to 15.000 MHz.
- (c) Connect J1 (RF IN/OUT) of the transceiver to a dummy load.
- (d) Key the transceiver in CW mode.

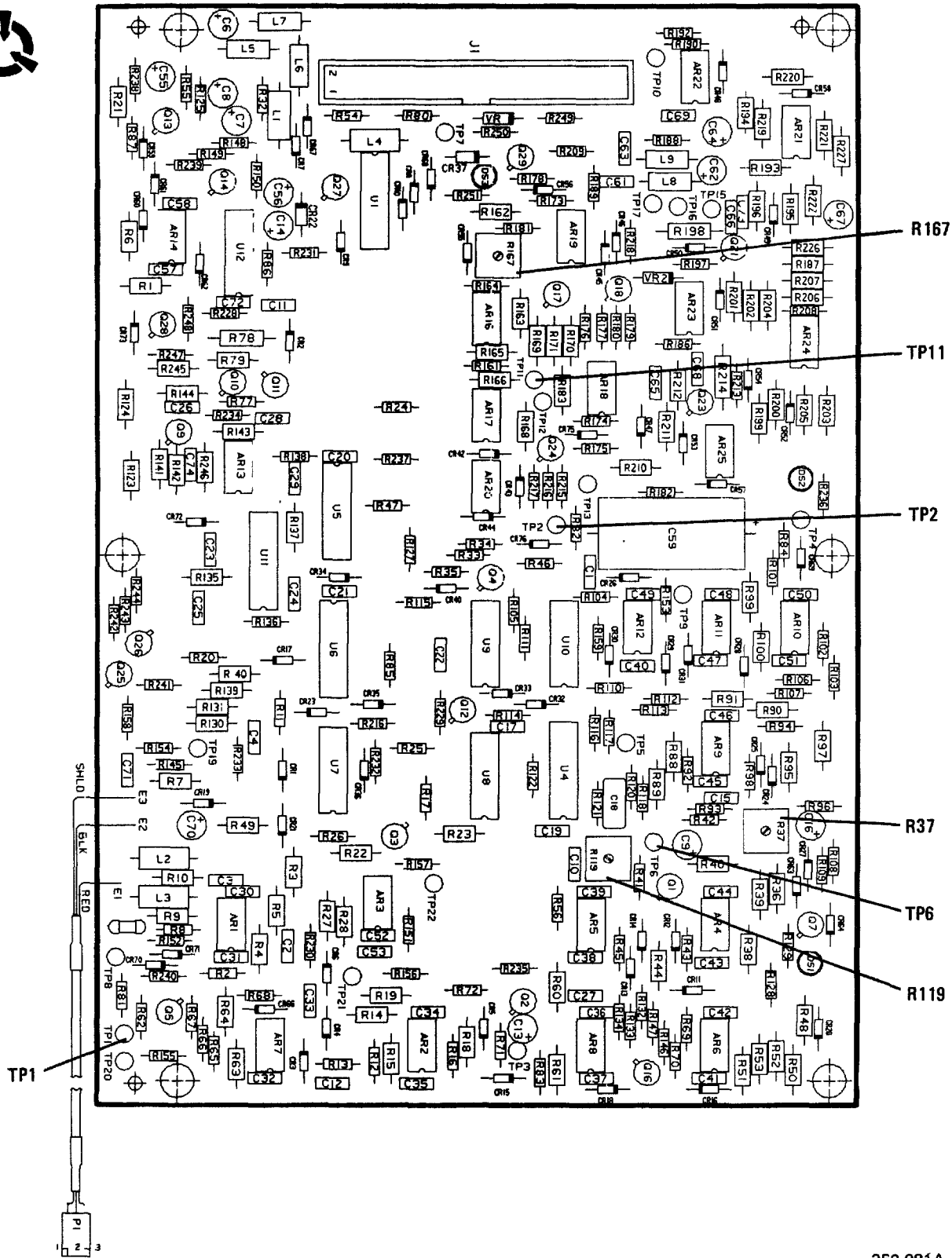

Figure 6-7. AGC/TGC PWB Assy

350-081A

- (e) Read the voltage on TP2 with a high-impedance (10 megohms or greater) DC voltmeter. This voltage should be +8 ±0.25 Vdc.
- (f) Connect the voltmeter to TP1.
- (g) Slowly turn R37 clockwise until the voltage at TP1 is within 100 mV of the TP2 voltage. For example, if the voltage at TP2 was +8.05 Vdc, you would adjust R37 clockwise until the voltage at TP1 was +7.95 to +8.15 Vdc.

g. RECEIVER PWB ASSY A1A7 (figure 6-8).

**(1) L24, 455 KHZ IF Peaking Adj.**

- (a) Select AME mode, AGC OFF on the transceiver front panel.
- (b) Inject a 455 KHz, -80 dBm signal into J5.
- (c) Connect an oscilloscope to TP1.
- (d) Adjust L24 for maximum AC signal at TP1.

**(2) R42, Gain Adjustment.**

- (a) Select AME mode, AGC OFF on the transceiver front panel.
- (b) Inject a 455 KHz signal at -80 dBm into J5.
- (c) Connect an oscilloscope to TP1.
- (d) Adjust RF GAIN control fully clockwise.
- (e) Adjust R42 for 35 mV pk-pk on the oscilloscope.

**(3) R197, AGC Adjustment**

- (a) Select AME mode, AGC OFF on the transceiver front panel.
- (b) Adjust the RF GAIN control fully clockwise.
- (c) Inject a 455 KHz signal at -80 dBm into J5.

- (d) With an oscilloscope, verify that the signal at TP1 is 35 mV pk-pk. If it is not, adjust R42 (GAIN ADJUST). See paragraph 2 above.

- (e) Rotate the RF GAIN control fully counterclockwise.

- (f) Increase the signal strength to -20 dBm.

- (g) Adjust R197 for 35 mV pk-pk at TP1.

- (h) Reduce the signal strength to -80 dBm, rotate the RF GAIN control fully clockwise, and check the signal at TP1. It should be 35 mV pk-pk. If it is not, adjust R42 (GAIN ADJUST) and repeat steps e-h.

**(4) L6, 39.545 MHZ OSC Peaking Adj.**

- (a) At J1, inject a 40.455 MHz, -40 dBm signal.

- (b) Connect a spectrum analyzer to J2. Observe the output at 455 KHz. Set up as follows:

- Input Attn.....0 DB
- Scan Width.....0.5 KHZ/Div.
- Band Width.....0.3 KHZ
- Scan Time/Div..... 50 msec
- Log Ref Level.....0 dBm
- Scan Trigger.....Auto
- Scan Mode.....Int
- Video Fltr..... Off
- Log/Linear..... 10 DB Log

**NOTE**

It may be necessary to start at a higher scan width to find the desired signal initially.

- (c) Adjust L6 for maximum signal at this frequency (the signal should be approximately -34 dBm or greater).

**(5) R93, Sidetone Level Adjustment.**

- (a) Select CW mode.

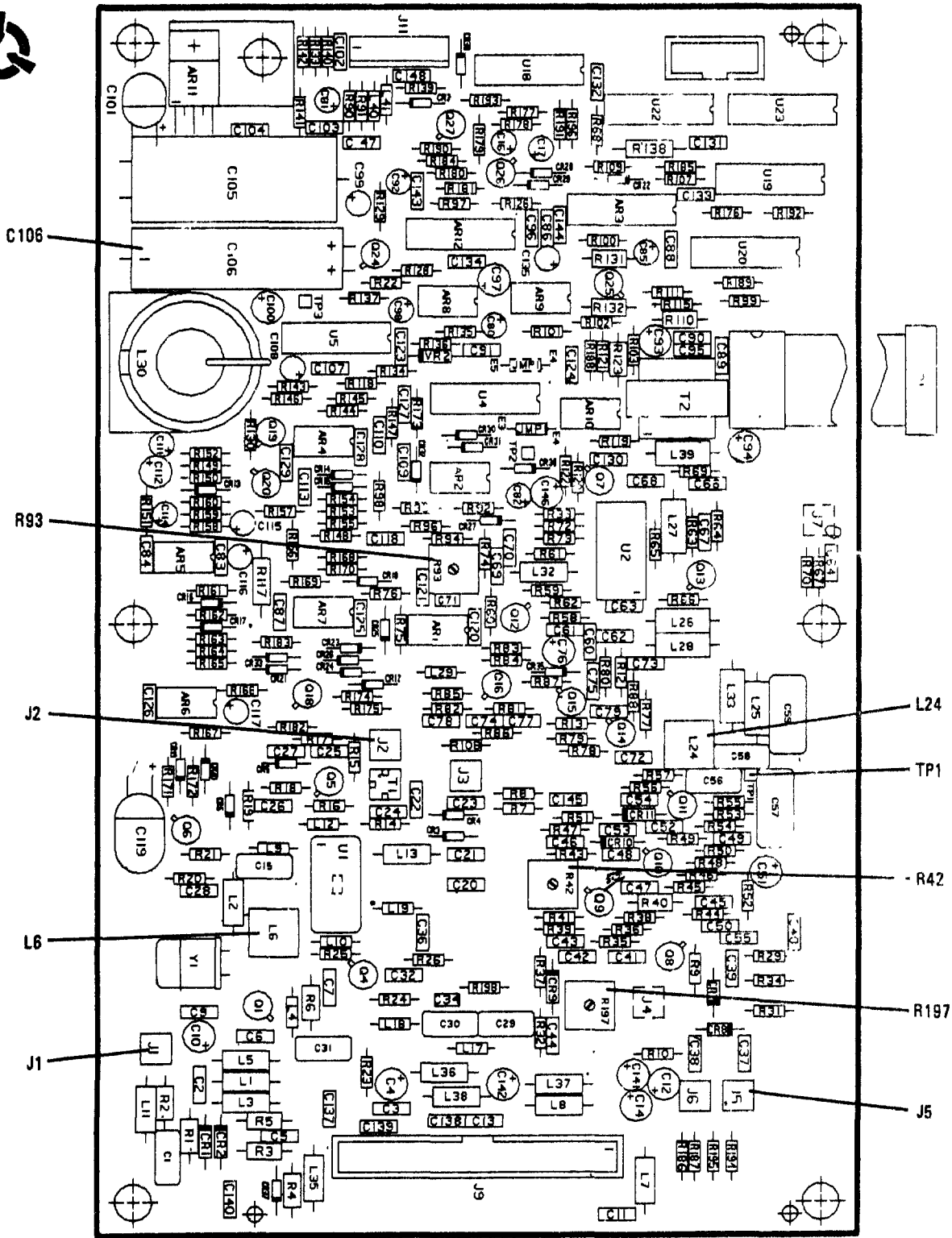

350-082A

Figure 6-8. Receiver PWB Assy

- (b) Connect oscilloscope to (-) lead of C106.
- (c) Using a signal generator, inject a 40.455 MHz signal into J1 at -40 dBm.
- (d) Adjust R93 so that, for a given volume control setting on the front panel, the audio level of the sidetone (when the transceiver is keyed) is about the same as the received audio level.

#### h. CRYSTAL OSCILLATOR ASSEMBLY A1A8.(figure 6-9).

The purpose of the following procedures is to determine whether the Crystal Oscillator Assembly is functioning properly and, if it is found to be off-frequency, to attempt to adjust the frequency to the specified value.

- (1) Obtain an SMB female to BNC adapter cable of 18 inches (or less) in length. Connect the SMB female end to the Crystal Oscillator Assembly, and connect the BNC end to a frequency counter. The frequency counter should be referenced to a frequency source whose stability is better than 1 part in  $10^8$  per day.
- (2) Check that the frequency of the Crystal Oscillator Assembly is 10.000000 ( $\pm$  the offset, if specified on the label) MHz.

#### NOTE

Some Crystal Oscillator Assemblies may have an offset. The reason for this offset is to enable the Crystal Oscillator Assembly to meet the temperature stability specification. For example, the Crystal Oscillator Assembly may have to be set for a room-temperature ( $25^{\circ}$  C) frequency of 10.000001 MHz in order to meet the temperature stability specification. In this case, the offset would be +1 Hz.

- (3) If the frequency is not correct, do the adjustment procedure below.

- (a) Remove the screw from the top of the Crystal Oscillator Assembly.
- (b) Insert a tuning tool, and adjust the variable capacitor for 10.000000 ( $\pm$ the offset, if specified on the label) MHz on the frequency counter.
- (c) If the Crystal Oscillator Assembly cannot be adjusted to specification, discard it.

#### i. REFERENCE/BFO PWB ASSY A1A9 (figure 6-10).

##### (1) **L1, L2, 40 MHz REF Output Peaking Adj.**

- (a) Connect an oscilloscope to the end of R15 closer to L2.
- (b) Adjust both L1 and L2 for maximum amplitude of the 40 MHz sine wave. These adjustments are interactive, so you may have to go back and forth a couple of times to get the best result.

##### (2) **C35, VCO Frequency Adjust**

- (a) Center-tune the BFO (455.00 KHz). (The BFO is automatically center-tuned in USB or LSB receive mode, as long as the BFO key on the transceiver front panel is not activated.)
- (b) Connect a DC voltmeter to TP2
- (c) Adjust C35 for +6.5 Vdc at TP2.

##### (3) **L14, 10 MHz Standard Input Adjustment**

- (a) Connect an oscilloscope to the ungrounded end of R99.
- (b) Adjust L14 for maximum signal on the oscilloscope.

#### j. SYNTHESIZER PWB ASSY A1A10 (figure 6-11).

##### (1) **R1, R3, R4: API Alignment Procedure**

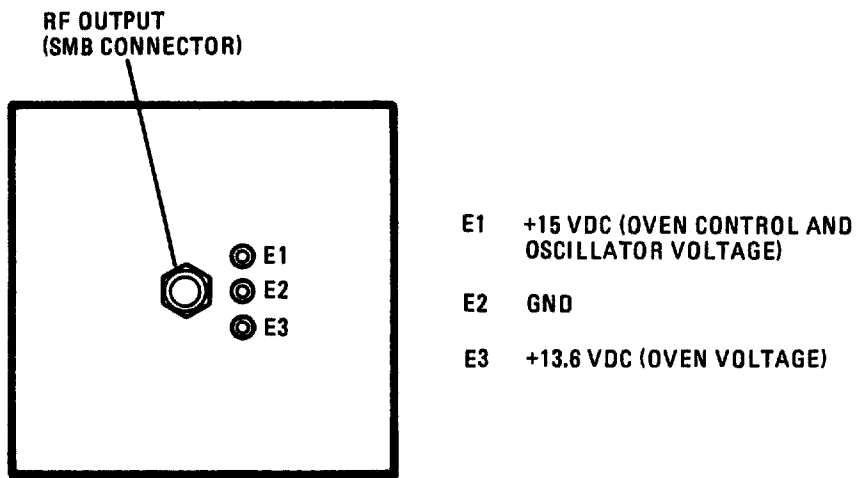

350-049A

Figure 6-9. Crystal Oscillator Assy (Bottom View)



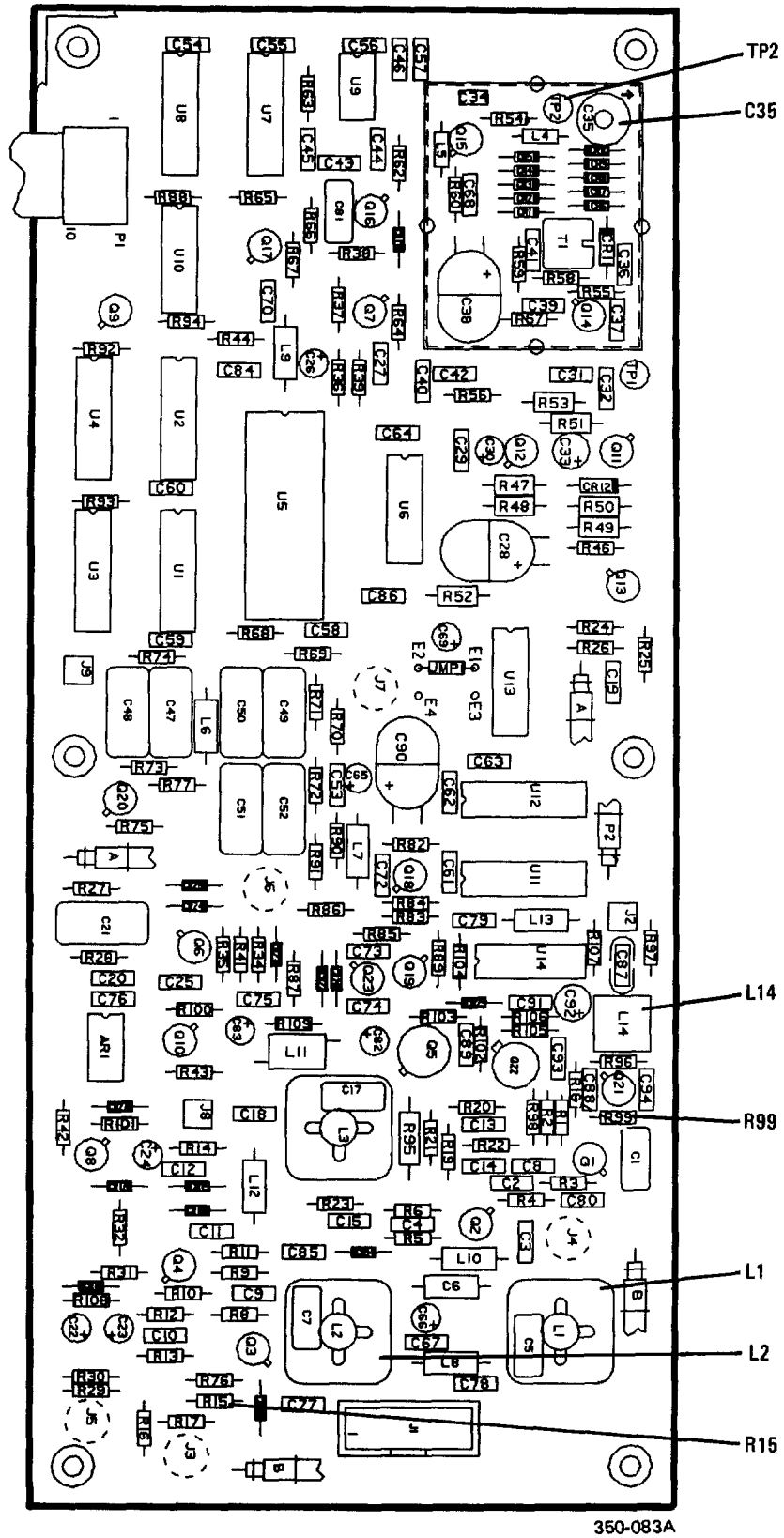

350-083A

Figure 6-10. Reference/BFO PWB Assy

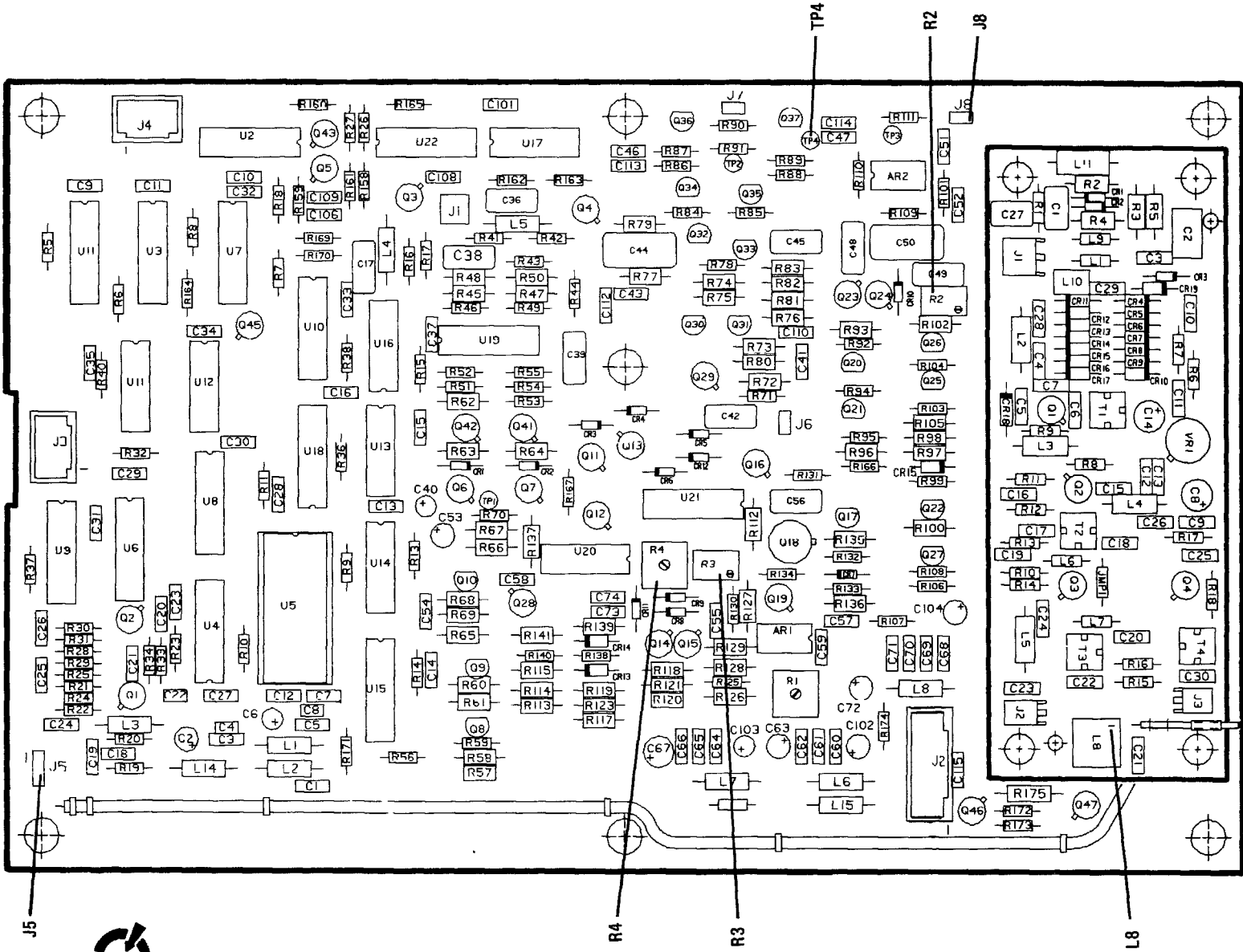

350-084A

Figure 6-11. Synthesizer PWB Assy

- (a) Remove the cover from the Synthesizer PWB Assy. sideband (45.00600 MHz), which should be at the center of the display
- (b) Set the transceiver to 4.54800 MHz USB.
- (c) Disconnect the coax cable from J5 on the First Converter PWB Assy. Using an SMB to BNC adapter, connect this cable to the RF input of a spectrum analyzer.
- (d) Set the spectrum analyzer controls as follows:
  - Input Attenuation: .....20 dB
  - Scan Width:.....05 MHz per division
  - Bandwidth: .....10 KHz
  - Scan Time Per Division: .2 ms
  - Log Reference Level: ...+10 dBm
  - Scan Trigger: .....Auto
  - Scan Mode: .....Int
  - Video Filter: .....Off
  - Log/Linear: .....10 dB log
- (e) Adjust the frequency control on the spectrum analyzer to center the Synthesizer output, which is at 45.00300 MHz.
- (f) Readjust the spectrum analyzer to give a center frequency of 45.00600 MHz with a bandwidth of 100 Hz and a scan width of 1 KHz per division. Adjust the scan time to maintain a calibrated display.
- (g) Set the video filter to 10 KHz, and adjust the log reference level to place the peak of the Synthesizer output on the top line of the display.
- (h) The spectrum analyzer display should now be centered on the API sideband, which is 3 KHz above the Synthesizer output at 45.00300 MHz.
- (i) Set the spectrum analyzer scan mode to manual, and set the video filter to 10 Hz.
- (j) Adjust the manual scan control on the analyzer to display the peak of the API
- (k) Adjust trim pot R3 on the Synthesizer to reduce the sideband level (at 45.00600 MHz) to a minimum. If the API circuitry is functioning properly, you should be able to reduce the sideband level at least 50 dB below the Synthesizer output level (at 45.00300 MHz), and typically better than 60 dB.
- (l) Set the transceiver frequency to 4.54530 MHz.
- (m) Adjust the center frequency of the spectrum analyzer to 45.00000 MHz, the scan width to 1 KHz per division, and the bandwidth to 100 Hz. Adjust the log reference level to place the peak of the Synthesizer output at the top line of the display.
- (n) Set the analyzer scan mode to manual, set the video filter to 10 Hz, and use the manual scan control to display the peak of the API sideband 3 KHz above the Synthesizer output (at 45.0030 MHz).
- (o) Adjust trim pot R4 on the Synthesizer to reduce the sideband level (at 45.0030 MHz) to a minimum. If the API circuitry is functioning properly, you should be able to reduce the sideband level at least 50 dB below the Synthesizer output level (at 45.0030 MHz), and typically better than 60 dB.

**NOTE**

The API 4 adjustment potentiometer, R1, need not be adjusted, since the maximum frequency resolution of the transceiver is 10 Hz.

**(2) L8, 40.455 MHz Trap Adjustment.**

- (a) Remove the covers from the Synthesizer PWB Assy and the VCO Assy. (The VCO Assy is the subassembly at the back of the Synthesizer PWB Assy.)

- (b) Remove jumper P3 from J5, pins 2 and 3.
- (c) Connect a suitable test cable (ITT Pomona Electronics 3787-C-36 or equivalent) from J5 pin 3 and J5 pin 1 (ground) to a frequency counter.
- (d) Remove jumper P2 from J8.
- (e) Connect the + terminal of a DC power supply to pin 2 of J8 (pin 2 is the one closer to the VCO Assembly) and the - terminal to TP4 (ground).

**CAUTION**

The voltage on the power supply should not exceed 12 Vdc.

- (f) Disconnect the coax cable from J5 on the First Converter PWB Assy. Using an SMB to BNC adapter, connect this cable to the RF input of a spectrum analyzer.
  - (g) Adjust the power supply to produce a frequency reading of  $40.455 \pm 0.100$  MHz on the frequency counter.
  - (h) Adjust the spectrum analyzer controls to center the Synthesizer output signal at  $40.455 \pm 0.1$  MHz. Set the analyzer scan width to .05 MHz per division. Set bandwidth to 30 KHz.
  - (i) Using a non-inductive tuning tool, adjust L8 on the VCO Assembly for a minimum signal level on the spectrum analyzer.
- (3) **R2, 100 KHz Sideband Null Adjustment**
- (a) Remove the cover from the Synthesizer PWB Assy.
  - (b) Disconnect the coaxial cable from J5 on the First Converter PWB Assy.

- (c) Using an SMB to BNC adapter, connect this cable to the RF input of the spectrum analyzer.
- (d) Set the transceiver to 14.54500 MHz USB.
- (e) Adjust the spectrum analyzer to center the Synthesizer output at 55.000 MHz on the analyzer display.
- (f) Set the input attenuation on the spectrum analyzer to 20 dB.
- (g) Adjust the Log Ref Level controls to place the peak of the Synthesizer signal (55.000 MHz) at the top line of the analyzer display (0 dB line).
- (h) Retune the center frequency of the spectrum analyzer to 55.100 MHz. The Synthesizer sideband at 55.100 MHz should now be displayed.
- (i) Decrease the Log Ref Level of the spectrum analyzer by 10 dB.
- (j) Adjust potentiometer R2 on the Synthesizer to reduce the sideband at 55.100 MHz to a minimum.

k. FRONT PANEL PWB ASSY A1A11A1. Aside from the AUDIO, RF GAIN, and SQUELCH controls, which are adjusted by the operator while the equipment is in use, there are six other potentiometers on the Front Panel PWB Assy. These are the VOX, ANTIVOX, MIC, LINE, PATCH RCV, and PATCH XMIT potentiometers, which are accessible through holes in the front panel. Since these are also adjustable by operators in the field, the adjustment procedures are contained in Chapter 4, Operation.

l. DISPLAY ASSEMBLY A1A11A2.

No adjustments.

m. TRANSCEIVER CONTROL PWB ASSY A1A12 (figure 6-12).

**Power Off Reset Potentiometer R2 Adjustment**

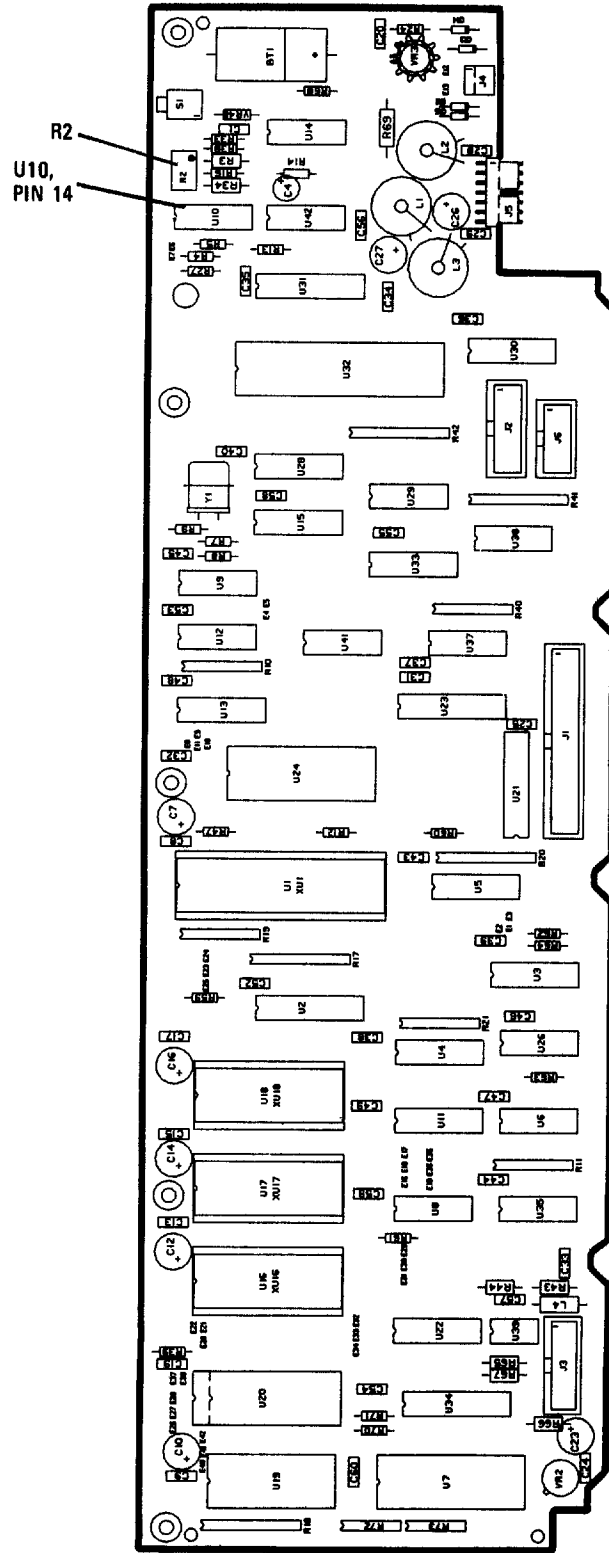

350-085A

Figure 6-12. Transceiver Control PWB Assy

- (a) Measure the +13.6 Vdc supply line at TP4 (yellow) on the Interconnect PWB Assy with a multimeter. Note the actual voltage.
- (b) Monitor the dc voltage at U10 pin 14 on the Transceiver Control PWB Assy with a multimeter.
- (c) Adjust R2 to produce a dc voltage at U10 pin 14 which is 0.56 times the voltage measured at TP4 on the Interconnect PWB Assy.

n. LPA/COUPLER INTERFACE PWB ASSY A1A13.

No adjustments.

o. MULTIVOLTAGE SUPPLY ASSY A1A14 (figure 6-13).

(1) **R61 (+5 V Adjustment)**

Adjust R61 for +5 Vdc at TP5 (green) on the Interconnect PWB Assy.

(2) **R4 (+15 V Adjustment)**

Adjust R4 for +15 Vdc at TP3 (orange) on the Interconnect PWB Assy.

p. INTERCONNECT PWB ASSY A1A15.

No adjustments.

q. AUDIO INTERFACE PWB ASSY A1A16 (figure 6-14).

(1) **PATCH Nulling Potentiometer R1**

**NOTE**

This adjustment only affects a 2-wire PATCH hookup.

- (a) Set the PATCH selector switch (S1) on the Audio Interface PWB Assy to the "2W" position.
- (b) Connect the nominal 600-ohm system termination across the "2W" PATCH terminals on TB1 (pins 2 and 3) at the rear of the transceiver.

- (c) Set the transceiver to receive USB mode at 2.4560 MHz.
- (d) Activate the BIT test tone by placing the jumper plug (PN65474-001, FSCM 00779) at J7 on the Low Pass Filter PWB Assy to the test position (between pins 2 and 3).
- (e) Listen for an audio tone from the speaker.
- (f) Select PATCH for the audio source, and select PATCH for the meter. Note the output level. Temporarily adjust the PATCH RCV potentiometer on the front panel to maximum clockwise.
- (g) Select AUDIO for the front panel meter, and adjust potentiometer R1 (accessible through a hole in the Audio Interface PWB Assy's frame) for a null (minimum reading) on the front panel meter.
- (h) Readjust the front panel PATCH RCV potentiometer to its original setting by using the PATCH meter position on the front panel. After completing the adjustment, be sure to replace the jumper plug at J7 on the Low Pass Filter PWB Assy to the normal position (between pins 1 and 2).

(2) **LINE Nulling Potentiometer R5**

**NOTE**

This adjustment only affects a 2-wire LINE hookup (as when a REMOTE CONTROL UNIT is connected to the 100 Watt Transceiver).

- (a) On the transceiver, select CW mode at 15 MHz. Connect J1 (RF in/out) on the rear of the transceiver to a 50 ohm dummy load.
- (b) Select the LINE meter.
- (c) Ensure sidetone is present.

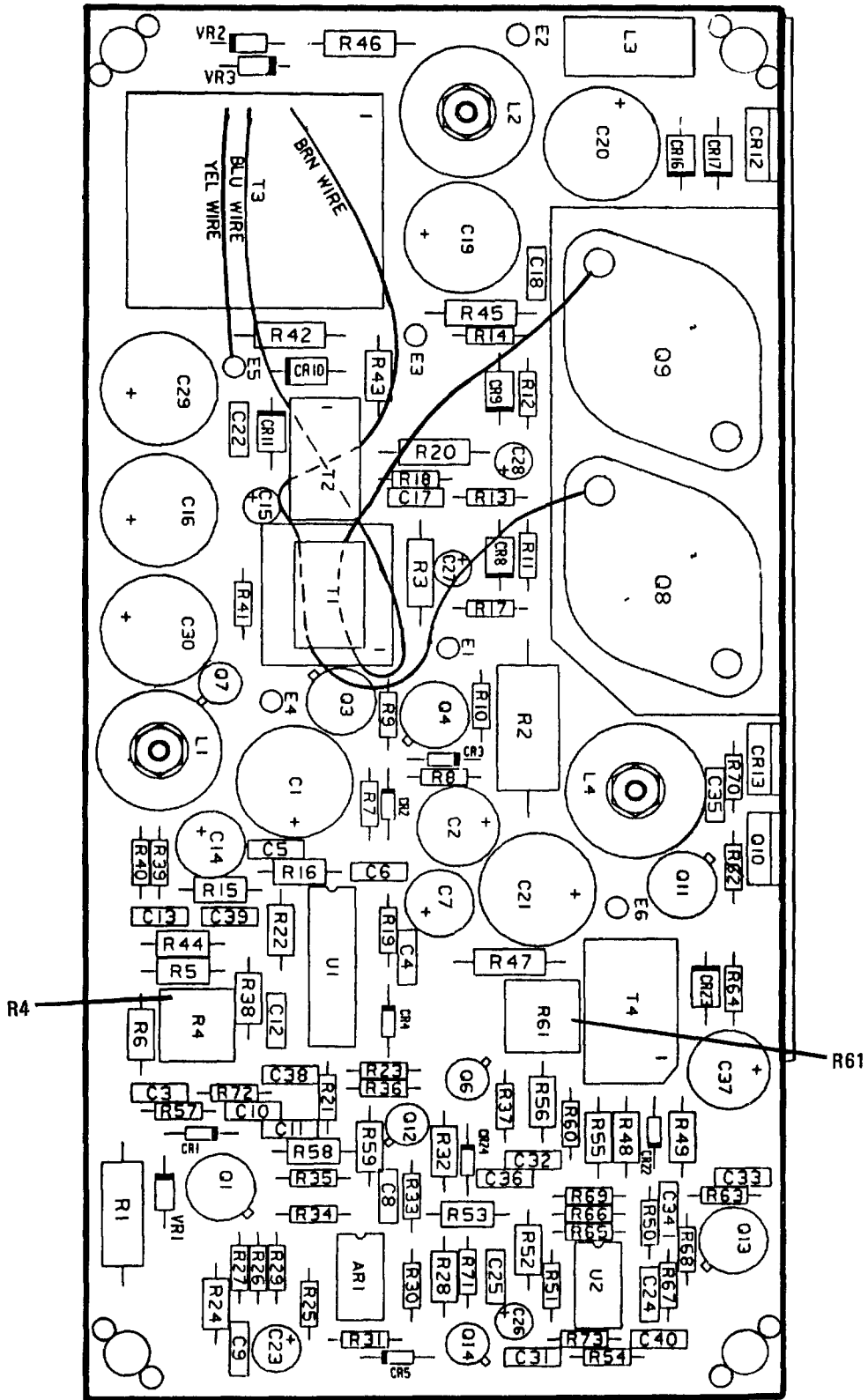
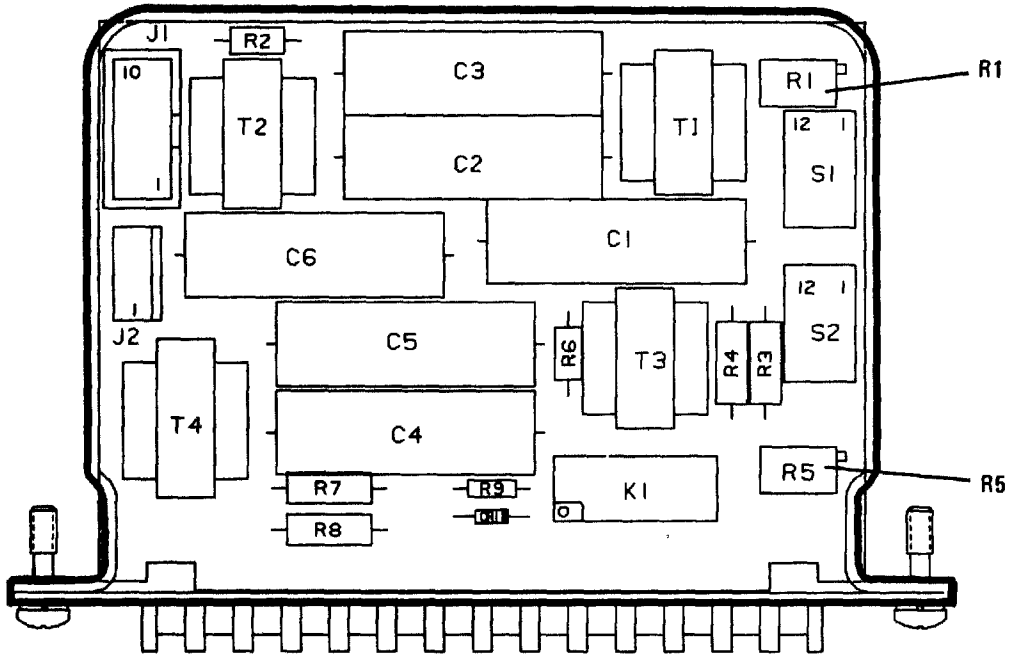

Figure 6-13. Multivoltage Supply PWB Assy



350-087A

Figure 6-14. Audio Interface PWB Assy



- (d) Connect the nominal 600-ohm termination across the "2W" LINE terminals on TB1 at the rear of the transceiver.
- (e) Set the LINE selector switch (S2) on the Audio Interface PWB Assy to the "2W" position. Note line level reading on front panel meter.
- (f) Adjust the LINE potentiometer on the front panel of the transceiver fully clockwise.
- (g) Key the transceiver with the CW key, and adjust R5 (accessible through a hole in the chassis frame and the Audio Interface PWB Assy's frame) for a null (minimum reading) on the meter.
- (h) Rotate the LINE potentiometer to its former position.

r. COUPLER CONNECTOR PWB ASSY A1A17.

No adjustments.

s. AFSK MODULE ASSY A1A18 (figure 6-15).

**(1) C22, Oscillator Frequency Adjust**

- (a) Select AFSK on the transceiver front panel.
- (b) Connect a frequency counter to TP3.
- (c) Adjust C22 for 1.24890 MHz  $\pm$ 100 Hz at TP3.

**(2) R8, TTL DC Offset Adjust**

- (a) Set the AFSK shift to 170 Hz with S1 on the AFSK IF Filter PWB Assy (figure 6-16).
- (b) Inject a 1000 Hz audio signal at pin 19 of J2. The signal level should be 50 mV rms.
- (c) Connect an oscilloscope to TP1.
- (d) Adjust R8 for equally spaced pulses on the oscilloscope (R8 has only minimal affect).

**(3) R21, Duty Cycle (+/-12 V) Balance Adjust**

- (a) Set the AFSK shift to 170 Hz with S1 on the AFSK IF Filter PWB Assy.
- (b) Inject a 1000 Hz audio signal at pin 19 of J2. The signal level should be 100 mV rms.
- (c) Connect an oscilloscope to TP2. (Use the DC coupled input to the oscilloscope.)
- (d) Adjust R21 so that the signal at TP2 is a symmetrical signal approximately  $\pm$  12 Vdc relative to ground at twice the audio input frequency.

**(4) R86, AFSK Meter Balance Adjust**

- (a) Set the AFSK shift to 170 Hz with S1 on the AFSK IF Filter PWB Assy.
- (b) Inject a 1000 Hz audio signal at pin 19 of J2. The signal level should be 100 mV rms.
- (c) Connect a DC voltmeter to the junction of R87 and R88.
- (d) Adjust R86 for +2.50 ( $\pm$ 0.05) Vdc on the meter.

**(5) R73, Detector Threshold Adjust**

- (a) Set the AFSK shift to 170 Hz with S1 on the AFSK IF Filter PWB Assy.
- (b) Inject a 1000 Hz audio signal at pin 19 of J2. The signal level should be 5 mV rms.
- (c) Connect a DC voltmeter to pin 1 of AR7A.
- (d) Adjust R73 for a positive transition to +13 Vdc or more on the meter. It maybe necessary to initially set R73 in the CW direction until a negative voltage is indicated.

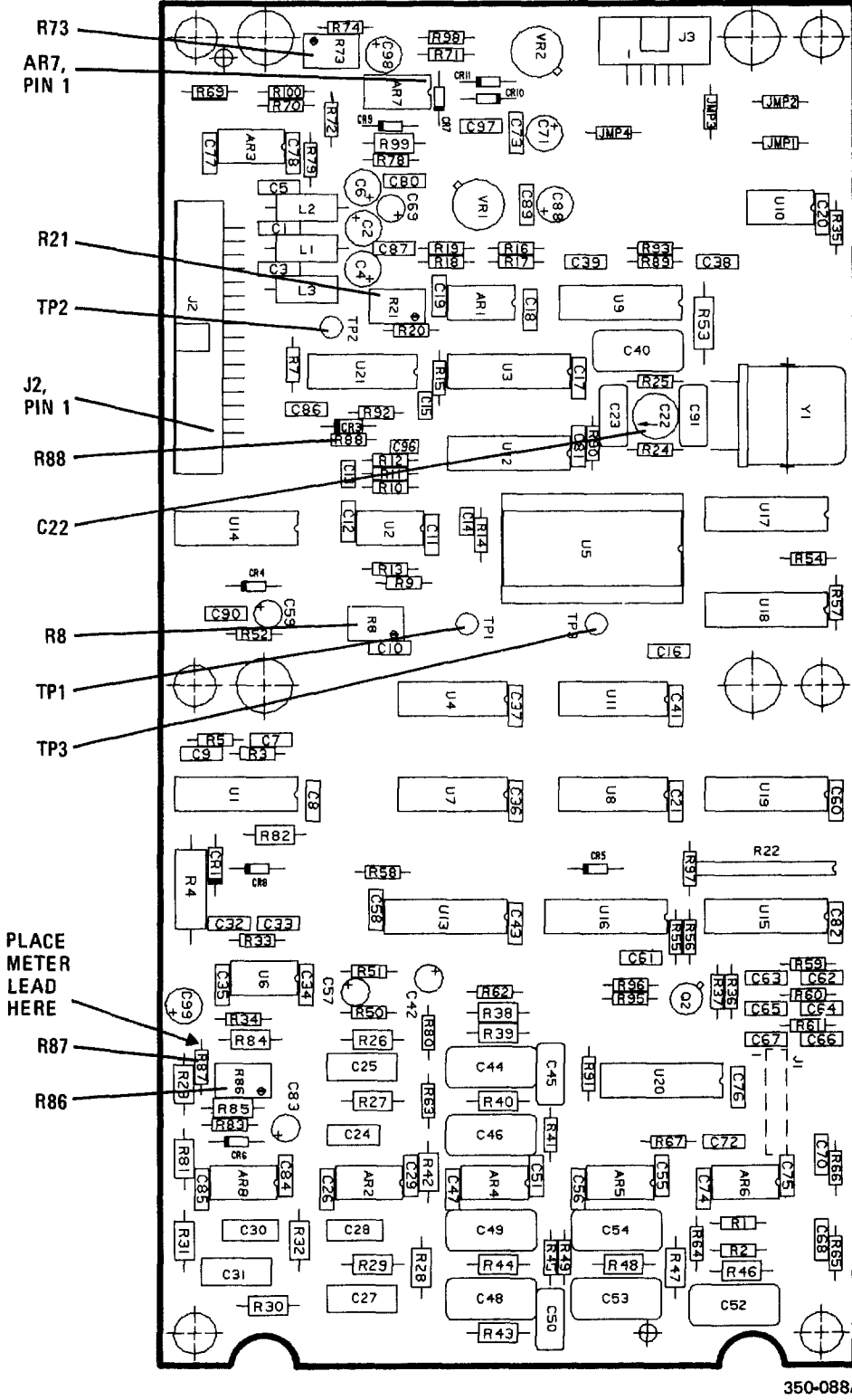
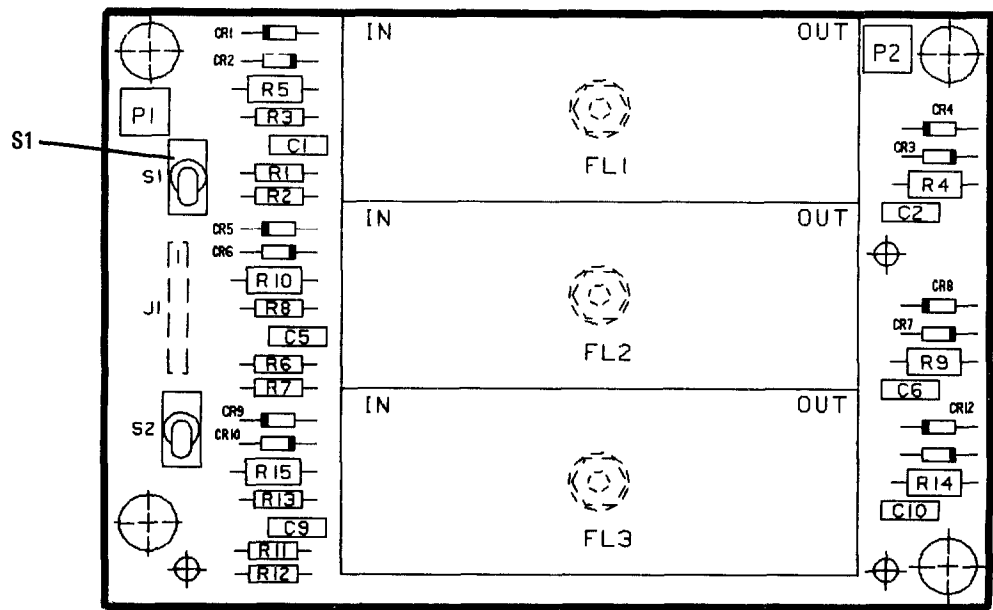

Figure 6-15. AFSK Keyer/Converter PWB Assy



350-090A

Figure 6-16. AFSK IF Filter PWB Assy

t. REMOTE CONTROL INTERFACE PWB ASSY A1A19.

No adjustments.

u. POWER SUPPLY PROTECTION AND CONTROL PWB ASSY A2A1.

No adjustments.

v. 13.6 V POWER SUPPLY ASSY A2A2 (figure 6-17).

**(1) R26, +13.6 Vdc Voltage Adjustment.**

(a) Set mode to USB.

(b) Adjust R26 for +13.6 Vdc ( $\pm 0.05$  Vdc) at TP4 (yellow) on the Interconnect PWB Assy, A1A15.

**(2) R28, AFSK/CW Voltage Cutback Adjustment**

(a) Set mode at CW or AFSK Mode.

(b) Adjust R28 for +12.3 Vdc ( $\pm 0.05$  Vdc) at TP4 (yellow) on the Interconnect PWB Assy A1A15.

**NOTE**

Maximum AC ripple at TP4 is 50 mVac.

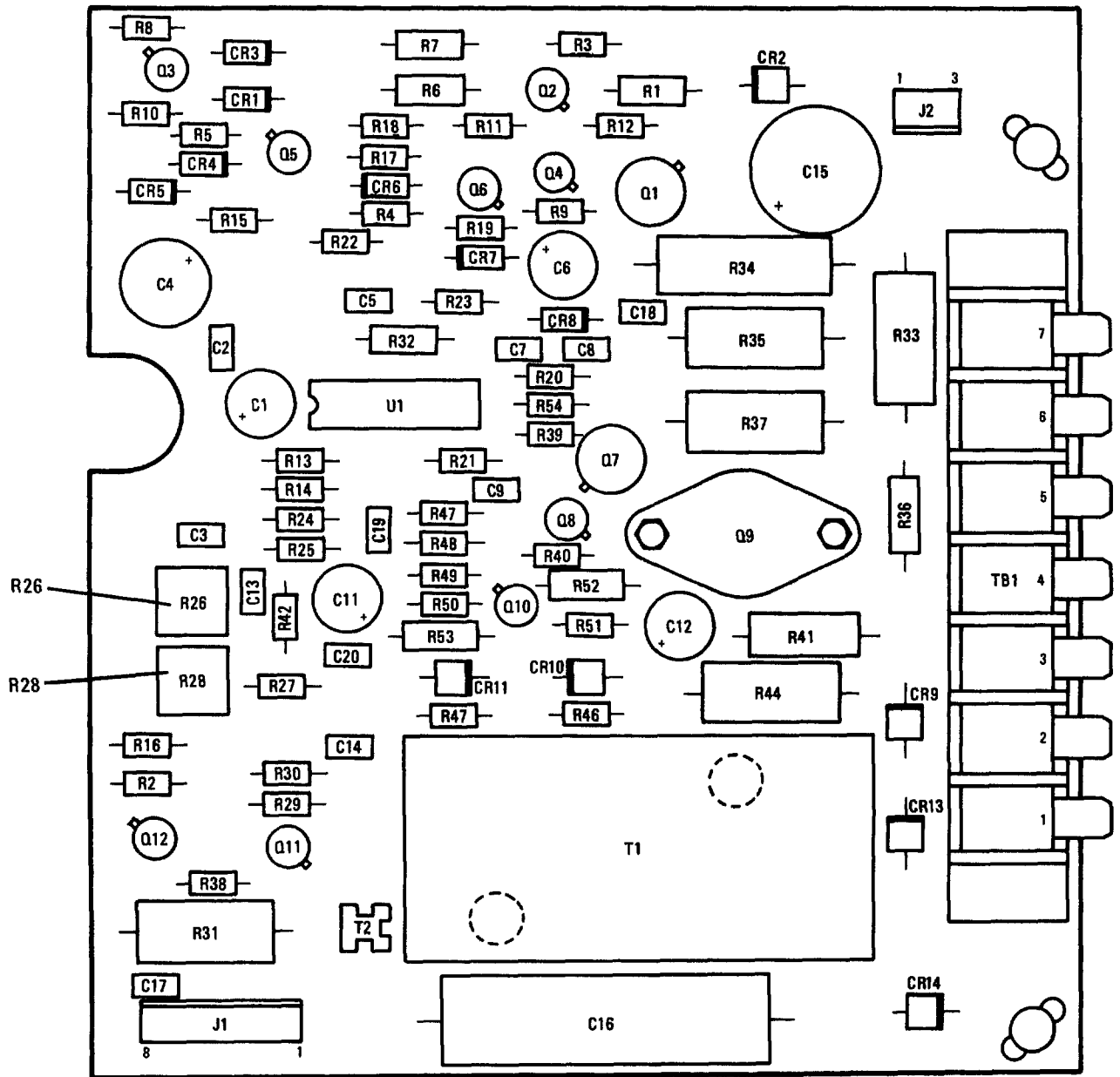

350-089A

Figure 6-17. 13.6 Vdc Power Supply PWB Assy

**MAINTENANCE**

**Section III. DIAGNOSTIC PROCEDURES**

**6-4. DEPOT MAINTENANCE PHILOSOPHY.** The diagnostic procedures presented in this chapter assume that equipment problems have already been isolated to one of the replaceable subassemblies listed below. This has been accomplished in the field using the BIT (Built-In Test) troubleshooting approach. (For a detailed description of BIT, see Chapter 6 in the On-Equipment Manual for the 100 Watt Transceiver, T.O. 31R2-2URC-81.) As a depot maintenance technician, your job is to take these defective subassemblies returned from the field, swap them with known good subassemblies in a properly functioning 100 Watt Transceiver (the "test bed"), and troubleshoot the defective subassemblies to the component level. Once you have identified and replaced the faulty component (resistor, capacitor, transistor, etc.), you will then perform whatever adjustment or alignment procedures are required to restore the subassembly to peak operating condition. To accomplish these tasks, you will need the procedures contained in this chapter, a complete set of schematics (in Chapter 8 of this manual), and the test equipment listed in Table 6-1. Also, refer to Appendix B, "Meter Functions." The following is a list of the subassemblies covered in Section III:

Multivoltage Supply Assy, A1A14..... 6-19  
 Interconnect PWB Assy, A1A15 ..... 6-20  
 Audio Interface PWB Assy, A1A16..... 6-21  
 Coupler Connector PWB Assy, A1A17..... 6-22  
 AFSK Module Assy, A1A18..... 6-23  
 Remote Control Interface PWB Assy,  
 A1A19..... 6-24  
 Power Supply Protection and Control  
 PWB Assy, A2A1..... 6-25  
 13.6 V Power Supply, A2A2..... 6-26

**6-5. EXCITER PWB ASSY, A1A1.**

a. Preliminary Procedure.

- (1) Remove the good Exciter PWB Assy from the test-bed 100 Watt Transceiver, and replace it with the faulty Exciter PWB Assy.
- (2) Power up the transceiver.
- (3) Connect a dummy load to the transceiver.
- (4) Check for the presence of the following power supply voltages on the board. Voltages should be within 0.5 V of the nominal value, except for the +10 Vdc, which should be within 0.25 V of the nominal value.

<u>Voltage:</u>	<u>Measure at:</u>
+5 Vdc	+ side of C119
+15 Vdc	+ side of C125
-15 Vdc	- side of C122
+10 Vdc	TP2

- (5) If the voltages check good, run the receive-transmit BIT test.

b. Interpreting the BIT Fault Codes. Use the fault codes listed below as a guide in troubleshooting the Exciter PWB Assy. Refer to the section corresponding to the fault code you get. In the event that the BIT test runs without generating a fault code, look for other obvious symptoms, such as no VOX operation or no PATCH transmit. Then refer to the "ADDITIONAL SYMPTOMS" section following the BIT code sections.

**NOTE**

In order to find the location of components on circuit boards, refer to the circuit board layout drawings in the Alignments section of this chapter or in the Illustrated Parts Breakdown in chapter 7.

<b>SUBASSEMBLY</b>	<b>PARAGRAPH</b>
Exciter PWB Assy, A1A1.....	6-5
IF Filter PWB Assy, A1A2.....	6-6
First Converter PWB Assy, A1A3 .....	6-7
Power Amplifier Assy, A1A4.....	6-8
Low Pass Filter PWB Assy, A1A5.....	6-9
AGC/TGC PWB Assy, A1A6.....	6-10
Receiver PWB Assy, A1A7.....	6-11
Crystal Oscillator Assembly, A1A8.....	6-12
Reference/BFO PWB Assy, A1A9.....	6-13
Synthesizer PWB Assy, A1A10.....	6-14
Front Panel PWB Assy, A1A11A1.....	6-15
Display Assembly, A1A11A2.....	6-16
Transceiver Control PWB Assy, A1A12.....	6-17
LPA/Coupler Interface PWB Assy, A1A13....	6-18

BIT Test Description for the  
Exciter PWB Assy

- (1) Checks for the presence of the Exciter PWB Assy by sending data to the board and receiving the MCB loopback bit in reply.
- (2) Applies a 1 KHz test signal to the MIC input, selects USB, and keys the transceiver.
- (3) Verifies the presence of the 455 KHz IF output from the Exciter PWB Assy.
- (4) Verifies the presence of the 40.455 MHz IF output from the Exciter PWB Assy.
- (5) Disables the 1 KHz test signal, selects AME mode, and verifies the presence of the 40.455 MHz IF output from the Exciter PWB Assy.
- (6) Selects CW mode and verifies the presence of the 40.455 MHz IF output from the Exciter PWB Assy.

1A1A1-0

This fault code indicates that the microprocessor sent data to the Exciter PWB Assy but did not receive the expected MCB loopback bit in reply.

Connect an oscilloscope (a storage scope is best) to pin 11 of U24. This pin should go high momentarily at the start of the receive-transmit BIT test. If it does not, the problem is U19-U24 or their associated circuitry. If the signal at pin 11 of U24 is good, then the problem is U25, U20D, U20C, or their associated components.

1A1A1-1

This fault code indicates that there is no 455 KHz IF output from P1 on the Exciter PWB Assy.

- (1) Connect an oscilloscope (a storage scope is best) to pin 15 of U11. Run the receive-transmit BIT test. You should see a 1 KHz signal at 50 mV pk-pk momentarily on the oscilloscope. If you do not, U11 or one of its surrounding components is probably bad. If the signal is good, proceed to step 2.

- (2) Check the audio signal path as follows:
  - (a) On the transceiver, select MIC as the audio source.
  - (b) Set the CLIP function to off.
  - (c) Inject a 1 KHz, 600 uV audio signal into pin D of the front panel HANDSET/MIC connector J2.
  - (d) Key the transceiver with the 2ND, TX KEY buttons on the front panel.
  - (e) Look at TP4 with the oscilloscope. You should see a 1 KHz signal at approximately 100 mV pk-pk.
  - (f) If the signal at TP4 is not good, check for the signal at AR1 pin 6. If the signal is bad there, the problem is AR1 or its associated components. If the signal is good at AR1, trace the signal through the following stages:
 

U3, pin 14	AR7, pin 7
U5, pin 10	U9, pin 15
AR3A, pin 1	U9, pin 12
U9, pin 3	U11, pin 4
  - (g) If the signal at TP4 is good, proceed to step 3.

- (3) Check the BFO as follows:

**NOTE**

The transceiver is keyed during the following steps.

- (a) Check pin 8 of U12 for a 455 KHz signal at 300 mV pk-pk.
- (b) If the signal is not good there, check for a problem in CR11 or its associated components. If these components appear good, check for a problem in the CARRIER ENABLE line. Skip to step 4.
- (c) If the signal is good at U12 pin 8, connect a spectrum analyzer to P1 and check for 454 and 456 KHz at -35 dBm each. If these signals are bad, the

problem is probably U12. If the signals are good, the problem is in the BIT Detector circuit (Q2, Q3, and their associated components).

- (4) Check the CARRIER ENABLE line as follows:

**NOTE**

The transceiver is keyed during the following steps.

- (a) Check the collector of Q25. You should see approximately +5.50 Vdc. If it is high, there is probably something wrong in the CR11 circuitry at the pin 8 input to U12.
- (b) If the collector of Q25 is low, check for a low at pin 9 of U15. If it is low, either Q25 is bad or the CARRIER ENABLE line is shorted to ground.
- (c) If pin 9 of U15 is high, check for a high at pin 5. If pin 5 is not high, the problem is in U27, U11, U13, U14A, U14B, or Q21.
- (d) If pin 5 is high, check for a low at pin 6. If pin 6 is not low, the fault is probably in U14C or Q22.
- (e) If pin 6 is low, verify that pins 3 and 7 are high. Check for a low at pin 10. If these levels are not correct, U15 is probably bad.
- (f) If pins 3, 7, and 10 are good, check for a high at pin 2. If pin 2 is not high, the fault is probably in AR10A, Q24, or U16 (less likely).
- (g) If pin 2 is high, the problem is probably U15.

**1A1A1-2**

This fault code indicates that there is no 40 MHz IF output at J3 in the transmit USB mode.

- (1) Set up the transceiver as follows:
- (a) Select USB on the front panel.

- (b) Inject a 455 KHz, -18 dBm signal at P2.
- (c) Connect a spectrum analyzer to J3, with a 10 dB attenuator pad between the analyzer and J3.

- (2) Key the transceiver by pressing 2ND, TX KEY. You should see a 40.455 MHz signal at -6 dBm (+/-2 dB) on the analyzer (this takes into account the attenuator pad). If the signal is good, proceed to step 3. If it is bad, proceed to step 4.

- (3) The BIT Detector circuit is at fault. Check it as follows:

- (a) Since the BIT Detector is active only during the BIT test, you must unsolder the end of R200 that connects to pin 11 of U21.
- (b) Apply +5 Vdc to the disconnected end of R200. (You may use the +5 Vdc on the board by connecting a jumper to R200.) The BIT Detector is now activated.
- (c) Check for a low on the collector of Q20. If it is not low, work your way back through Q20, Q19, Q28, and their associated components.

- (4) Look at the collector of Q7 with an oscilloscope. You should see a 455 KHz signal at 17 V pk-pk. If this signal is bad, the problem is in Q4-Q7 or their associated components. Another possibility is a fault in the ALC circuitry. Check it as follows:

- (a) Look at AR12 pin 1 with a DC voltmeter.
- (b) If the voltage is +8.2 Vdc or greater, then the problem is in CR17 through AR12.
- (c) If the voltage at AR12 pin 1 is less than +7.8 Vdc, check TP1.
- (d) If TP1 is +2.0 Vdc or greater, the problem is in the AR12 or Q9 circuitry. If TP1 is less than +1.6 Vdc, then the problem is the Q10, Q11, or CR15 circuitry.



- (5) If the signal at the collector of Q7 is good, look at the collector of Q15 with the oscilloscope. You should see a 40 MHz signal at 2.3 V pk-pk (minimum). If the signal is bad, the problem must be Q15 and its associated components.
- (6) If the signal at the collector of Q15 is good, check the TGC Attenuator as follows:
  - (a) CR29 should be forward biased by more than 0.5 V, and CR30 should not be forward biased by more than 0.4 V.
  - (b) If not, troubleshoot the CR29, CR30 circuitry.
- (7) If the TGC Attenuator circuitry is good, the problem is in the IF Amplifier (Q17, Q18, and their associated components) or the Mixer circuitry (M1 etc.).

**NOTE**

To do signal tracing in this area, you need a high-impedance probe for your spectrum analyzer.

**1A1A1-3**

This fault code indicates that there is no 40 MHz IF output at J3 in the transmit AME mode.

Since the BIT test passed in USB mode, the problem has to be in that part of the circuitry that is unique to AME, which is Q8 and its associated components or CR19, CR20, and CR12. With AME selected, CR12 should be forward biased; CR19 and CR20 should be reverse biased.

**1A1A1-4**

This fault code indicates that there is no 40 MHz IF output at J3 in the transmit CW mode.

Since the BIT test passed in both USB and AME modes, the problem has to be in the circuitry that is unique to CW.

- (1) Check the CW keyline circuitry as follows:
  - (a) Select CW mode on the transceiver.

- (b) Check pin 10 of U2. When the transceiver is keyed with the CW key, this pin should go to +5 Vdc.
- (c) If this is not the case, you have a keyline problem. The problem is most likely U1.

- (2) Connect an oscilloscope to pin 15 of U3. Check for a 1 KHz signal at 50 mV pk-pk when the transceiver is keyed with the CW key.
- (3) If the signal at pin 15 of U3 is bad, trace back through U3 and U2 to find the problem.

**1A1A6-4**

When you get this fault code, check the PPC light on the AGC/TGC Board. If the PPC light is on all the time when you key the transceiver in CW mode (with the CW key), then this fault code indicates that there is a problem in the 455 KHz Envelope Detector or in the TGC Attenuator.

Check the 455 KHz Envelope Detector as follows:

- (1) Key the transceiver in CW mode with the CW key.
- (2) Look at AR12 pin 1 with a DC voltmeter.
- (3) If the voltage is +8 Vdc or less, the fault is probably in the 455 KHz Envelope Detector (CR17, AR12, and their associated components).
- (4) If the voltage is greater than +8 Vdc, the problem is probably in the TGC Attenuator (CR28, CR29, CR30, and their associated components).

**ADDITIONAL SYMPTOMS**

The above fault codes cover the main signal path, but there are several other circuits on the Exciter PWB Assy that could cause problems. However, these circuits are readily identified by the following obvious symptoms:

**LOW PWR Indicator Comes On When FWD  
Power Meter Indicates Full Output**

The problem is probably in the LOW PWR Indicator circuitry: AR11A and its associated components. Also, check the adjustment of R254 (see the Alignments section).

**Incorrect VOX, ANTIVOX Operation**

Check AR4A, U6A, U6B, AR4B, and their associated components.

**Incorrect CLIPPER Operation**

Check AR8A, AR8B, U11A, and their associated components. The clipper level adjustment (R91) is preferential.

**METER SELECT Inoperative**

For the audio functions, check U18A, U18B, U18C, U17C, and their associated components. For power and VSWR functions, check U17A, U17B, and their associated components.

**No PATCH Transmit Audio**

Check U7A, U4C, and their associated components.

**No PATCH Receive Audio**

Check U7B, AR6A, and their associated components.

**No NBSV Transmit Audio**

Check T1, AR2B, U4B, and their associated components.

**No LINE (REMOTE) Transmit Audio**

Check AR2A, U4A, and their associated components.

**No AFSK Transmit Audio**

Check U3C and its associated components.

**6-6. IF FILTER PWB ASSY, A1A2.**

a. Preliminary Procedure.

- (1) Remove the good IF Filter PWB Assy from the test-bed 100 Watt Transceiver, and replace it with the faulty IF Filter PWB Assy.
- (2) Power up the transceiver.
- (3) Check for the presence of the following power supply voltages on the board. Voltages should be within 0.5 V of the nominal value.

<u>Voltage:</u>	<u>Measure at:</u>
+15 Vdc	+ side of C38
-15 Vdc	- side of C40
+5 Vdc	+ side of C36

- (4) If the voltages check good, run the receive-only BIT test.

b. Interpreting the BIT Codes. Use the fault codes listed below as a guide in troubleshooting the IF Filter PWB Assy. Refer to the section corresponding to the fault code you get. In the event that the test runs without generating a fault code, start at the beginning of the following procedures and work your way through to the end.

**BIT Test Description for the  
IF Filter PWB Assy**

- (1) The BIT Oscillator on the Low Pass Filter Board is activated.
- (2) Each filter is selected, and in each case the Synthesizer is used to center the BIT signal in each passband.
- (3) The presence of the 455 KHz IF output is verified at J2 for each filter selected.
- (4) If an AFSK Module is installed, the signal is sent to the AFSK filters via J5 and then returned at J6.

1A1A2-1

This fault code indicates that no IF signal (455 KHz) was detected at J5 on the IF Filter PWB Assy. The problem could be anywhere i. the signal path (except for filters 2 and 3), the control circuitry, or the BIT Detector.

- (1) Connect a signal generator to J1 on the IF Filter PWB Assy. Adjust it for a center frequency of 455 KHz at -20 dBm.
- (2) Connect a spectrum analyzer to J2 on the IF Filter PWB Assy.
- (3) Sweep the signal generator above and below the center frequency: 453 KHz to 457 KHz.
- (4) Select USB on the transceiver, and check for a peak response on the analyzer at 454 KHz.
- (5) Select LSB, and check for a peak response at 456 KHz.
- (6) Select CW, and check for a peak response at 455 KHz.
- (7) Check the gain of the board in USB mode, which should be about +17 dB at the peak filter response. The output signal at the analyzer should be about -13 dBm (this takes into account the 10 dB pad between the spectrum analyzer and the radio).
- (8) If all three filters perform as expected (peak at the correct frequency and level), the BIT Detector circuit (Q6, Q7, Q8, and their associated components) is probably faulty.
- (9) If two out of three filters perform as expected, then the remaining filter or its associated circuitry is at fault. In this case, check the output of the Filter Select Decoder, U1, and the outputs of the op amp. The following chart indicates which pin should be high for each filter selected:

	High	Low
FL1 (USB selected)	U1, pin 5	AR2, pin 1
FL2 (LSB selected)	U1, pin 6	AR1, pin 1
FL3 (CW selected)	U1, pin 7	AR1, pin 7

If the control voltages are good, then the filter is probably bad.

- (10) If none of the filters performs as expected, check the outputs of U1 as indicated in step 9 above.
- (11) Connect the spectrum analyzer to J5 on the IF Filter PWB Assy, and set the signal generator frequency to 455 KHz.
- (12) Check for a gain of +23 dB, which corresponds to an output signal level of +13 dBm on the analyzer.
- (13) If the signal is bad, the problem is in the Amplifier circuit (Q1, Q2, Q3, etc.). If the signal is good, troubleshoot the Impedance Matching circuit (Q4, Q5, and their associated components).

1A1A2-2, -3

These fault codes indicate a failure in a specific IF filter circuit (FL2 for 1A1A2-2 and FL3 for 1A1A2-3).

- (1) Connect a signal generator to J1 on the IF Filter PWB Assy.
  - (2) Inject a -20 dBm test signal at 456 KHz (for fault code 1A1A2-2) or 455 KHz (for fault code 1A1A2-3).
  - (3) Select LSB (for fault code 1A1A2-2) or CW (for fault code 1A1A2-3), and check for the correct voltage levels at U1 and AR1. Refer to the chart below:
- |                    | High      | Low        |
|--------------------|-----------|------------|
| FL2 (LSB selected) | U1, pin 6 | AR1, pin 1 |
| FL3 (CW selected)  | U1, pin 7 | AR1, pin 7 |
- (4) If the control voltages are good, check for the signal on both sides of the filter.

6-7. FIRST CONVERTER PWB ASSY, A1A3.

1A1A3-1

This fault code indicates that the received signal level at the J2 output of the First onverter PWB Assy is incorrect or missing.

- (1) Check the BIT Detector circuitry (Q7, AR1, Q8, and their associated components) as follows:
  - (a) Select USB mode, and set the operating frequency to 12.0000 MHz.
  - (b) Inject a -20 dBm RF signal into J1 at 12.001 MHz.
  - (c) Connect a spectrum analyzer to J2.
  - (d) Check for 40.454 MHz at -19 +/- 1 dBm on the analyzer (this value does not include the 10 dB attenuator pad).
  - (e) If the signal is good, check for a low (less than +0.5 Vdc) at the collector of Q8. If the collector of Q8 is not low, the problem is in the BIT Detector. If the collector of Q8 is low, the J6 connector is probably bad.
- (2) If the signal at J2 is bad, then check TP1 with an oscilloscope. You should see the amplified First Local Oscillator signal (52.455 MHz) at 18 V pk-pk (minimum). If the signal at TP 1 is bad, the problem is in the Local Oscillator Amplifier (Q13-Q16 and their associated components).

**NOTE**

Check the DC levels of all the transistors before attempting to signal trace.

- (3) If TP1 is good, check for the signal across R67 or R68. It should be 18 V pk-pk. If the signal is bad here, T4 is faulty or one of the Mixer transistors (Q17-Q20) is shorted. If the signal is good, proceed to step 4.
- (4) Unsolder one end of JMP1. Connect the spectrum analyzer to pin 1 of J7. You should see the input signal (-20 dBm) with a slight loss (1 dB or so). If the signal is bad, signal trace between J1 and J7.

a. Preliminary Procedure.

- (1) Remove the good First Converter PWB Assy from the test-bed 100 Watt Transceiver, and replace it with the faulty First Converter PWB Assy.
- (2) Power up the transceiver.
- (3) Connect a dummy load to the transceiver.
- (4) Check for the presence of the following power supply voltages on the board. Voltages should be within 0.5 V of the nominal value.

<u>Voltage:</u>	<u>Measure at:</u>
+5 Vdc	L5
+15 Vdc	+ side of C87
-15 Vdc	- side of C85
+15 V-T (keyed)	L41
+15 V-R	L42

- (5) If the voltages check good, run the receive-transmit BIT test.

- b. Interpreting the BIT Fault Codes. Use the fault codes listed below as a guide in troubleshooting the First Converter PWB Assy. Refer to the section corresponding to the fault code you get. In the event that the BIT test runs without generating a fault code, start at the beginning of the following procedures and work your way through to the end.

BIT Test Description for the First Converter PWB Assy

- (1) Activates the BIT Oscillator signal and verifies the presence of receive IF output to the Receiver Board.
- (2) In transmit, keys the transceiver in CW and verifies the presence of transmit RF output to the power amplifier.

**NOTES**

Q1, Q3, and Q4 should be on during receive.

Q2 comes on during transmit and during receive when the signal coming in is too strong.

- (5) If the signal is good at J7, do the following:
- (a) Replace JMP1.
  - (b) Inject a 40.455 MHz signal into J3 at -40 dBm.
  - (c) Key the transceiver with the 2ND, TX KEY buttons on the front panel.
  - (d) Look at J4 on the spectrum analyzer. You should see the operating frequency at a level of -20 dBm or greater (not including any pad before the analyzer). If the signal is good, the IF Amplifier (Q6 and its associated components) must be bad. If the signal is bad, proceed to step 6.
- (6) If the signal at J4 is bad, the problem is the Mixer or FL1. There are three possibilities:
- Case 1: The signal is present but low (-20 to -40 dBm). The problem is more likely the Mixer. Change all four Mixer transistors.
- Case 2: The signal is not present at all (less than -60 dBm). The problem is more likely the filter. Replace FL1.
- Case 3: This is the gray area, where the signal is between -40 and -60 dBm. In this case, replace the Mixer transistors first. If the problem persists, replace the filter.

**1A1A7-1**

This fault code indicates that the output of the Second Receiver Mixer (on the Receiver Board) is bad. Normally, this means that the fault is on the Receiver Board. However, sometimes, if the

signal out of the First Converter PWB Assy is weak, it will pass the BIT detector on that board but fail at the BIT detector on the Receiver Board.

Troubleshoot this fault code the same as fault code 1A1A3-1, except that you can skip step 1 (you can assume that the BIT detector is good and that the output from J2 is bad).

**1A1A3-2**

This fault code indicates that the RF transmit output from the First Converter PWB Assy to the Power Amplifier is bad.

- (1) Check the transmit BIT Detector circuit as follows:
- (a) Inject a 40.455 MHz signal into J3 at +4 dBm.
  - (b) Connect a spectrum analyzer to J4, with a 30 dB attenuator pad between the analyzer and J4.
  - (c) Key the transceiver with the 2ND, TX KEY buttons on the front panel.
  - (d) Check for a -12 dBm (this takes into account the 30 dB attenuator pad) signal (minimum) at the operating frequency on the spectrum analyzer.
  - (e) If the signal is good, check for a low (less than +0.5 Vdc) at the collector of Q12. If Q12's collector is low, then the J4 connector is probably bad. If Q12's collector is high, then the BIT Detector circuit (Q11, Q12, and their associated components) is bad.
- (2) If the signal at J4 is bad, then the problem has to be one of the following:
- pin diode switch CR10, CR11
  - pin diode switch CR7, CR8
  - amplifiers Q9, Q10, or their associated components
- (a) Check the diodes first. In transmit, CR10 should be forward biased and

CR11 should be reverse biased. CR8 should be forward biased, and CR7 should be reverse biased.

- (b) If the diodes check good, then the problem is in the Amplifier circuit: Q9, Q10, and their associated components.

1A1A4-1

This fault code indicates that the output from the Power Amplifier is bad. However, if the output from the First Converter PWB Assy is weak, it may pass the BIT detector on this board but may be insufficient to drive the Power Amplifier to its rated output.

Troubleshoot this fault code as follows:

- (1) Set up a test signal as in step 1 of the 1A1A3-2 fault code procedure.
- (2) Verify that the output of J4 is bad.
- (3) Proceed as in step 2 of the 1A1A3-2 fault code procedure.

6-8. POWER AMPLIFIER ASSY, A1A4.

a. Preliminary Procedures.

- (1) Visual inspection
  - (a) Check the Power Amplifier PWB Assy for damaged components.
  - (b) Check for pieces of metal lodged between the board and the heat sink.
- (2) Resistance measurements
  - (a) Using the R x 1 scale on a Simpson 260 Multimeter, check for a resistance of more than 100 ohms between E13 (+13.2 Vdc supply line) and ground. If the measurement indicates a short circuit, check to see whether Q8 and Q10 are insulated from the heat sink.
  - (b) Check for a resistance of more than 20 ohms between TP2 (+5.5 Vdc line) and ground.

If this measurement indicates a short circuit, check for a possible solder short along the +5.5 Vdc line.

- (c) Check for a short circuit between E13 and the collectors of Q1 through Q5.

If there is no continuity between E13 and the collector of Q1, check R65 and T2 to see if they are open.

If there is no continuity between E13 and the collector of Q2 or Q3, check R66, T4, and the 18 AWG jumper wire between E18 and E19.

If there is no continuity between E13 and the collector of Q4 or Q5, check R67, T6, and the 14 AWG jumper wires between E20 and E21 and between E1 and E22&

b. Alignment Procedures.

Do the alignment procedures for the Power Amplifier in Section II of this chapter. These may help to isolate or correct a fault.

c. Troubleshooting the Power Amplifier.

If the above procedures do not isolate problems in the Power Amplifier, here are a few other things you can do:

- (1) If you cannot drive the Power Amplifier to full output power at 30 MHz, check the RF Detector/VSWR Protection circuit.
  - (a) Measure the voltage at TP4. At full output power, this voltage should be approximately +4 Vdc.
  - (b) If the TP4 voltage is bad, then the problem is most likely in the RF Detector circuit.
  - (c) If the TP4 voltage checks okay, the RF Detector should be all right. Check the VSWR Protection circuit. The output of U1A, pin 1, should not be +4 Vdc unless J7 is not terminated in a 50-ohm load.

- (2) You can use an oscilloscope to check the base-to-collector signal gain for the pre-driver (Q1), drivers (Q2 and Q3), and final amplifiers (Q4 and Q5). Even though the signals are not pure sinewaves, there should be at least a 2:1 signal gain at each of these stages.
- (3) To check any of the above transistors, unsolder the base lead(s) and check the transistor with an ohmmeter.
- (4) If the Power Amplifier's performance varies significantly with temperature, check the bias control circuits for the drivers (Q2 and Q3) and final amplifiers (Q4 and Q5).

**6-9. LOW PASS FILTER PWB ASSY, A1A5.**

a. Preliminary Procedure.

- (1) Remove the good Low Pass Filter PWB Assy from the test-bed 100 Watt Transceiver, and replace it with the faulty Low Pass Filter PWB Assy.
- (2) Connect a dummy load to the output (J1) of the 100 Watt Transceiver.
- (3) Power up the transceiver.
- (4) Check for the presence of the following power supply voltages on the board. Voltages should be within 0.5 V of the nominal value.

<u>Voltage:</u>	<u>Measure at:</u>
+13.6 Vdc	L24
+15 Vdc	L25
-15 Vdc	L27
+13.6 V-A	L43
+13.6 V-B	L44

- (5) If the voltages check good, run the receive-transmit BIT test.

b. Interpreting the BIT Fault Codes. Use the fault codes listed below as a guide in troubleshooting the Low Pass Filter PWB Assy. Refer to the section corresponding to the fault code you get. In the event that the test runs without generating a fault code, start at the beginning of the

following procedures and work your way through to the end.

BIT Test Description for the Low Pass Filter PWB Assy

- (1) The BIT Oscillator on the Low Pass Filter PWB Assy is activated.
- (2) With all filters deselected, RF output is checked at J3. There should be no RF output.
- (3) RF output is checked again with each filter selected in turn.
- (4) If all filters pass this portion of the test, RF output is checked with all filters deselected again. This ensures that none of the relays is sticking.
- (5) Band 6 is then selected, and the Synthesizer is set to receive the BIT Oscillator signal.
- (6) In transmit, the transceiver is keyed in CW mode; and the RF output is checked by sampling it at J6.

1A1A5-1

This fault code indicates that the BIT Oscillator signal was not detected by the Receive BIT Detector at the J3 output. In the following steps, we will manually activate the BIT Oscillator signal and trace it through the board.

- (1) On J7, remove the jumper from pins 1 and 2 and insert it on pins 2 and 3.
- (2) Set the transceiver for a frequency of 2.456 MHz USB.
- (3) Listen for a tone with a signal strength of 16-19 segments on the front panel FWD meter.
- (4) If the tone is audible and of the correct strength, the problem has to be in the BIT ENABLE line (J5, pin 13; R40; C186) or in the Receive BIT Detector.
- (5) If the tone is not audible, do the following:

- (a) Visually check relays K1 and K7. They should be closed.
- (b) Check for +13.6 Vdc on both sides of L43 and L44.
- (c) Check the BIT ENABLE line. There should be a logic HI on pin 7 of J5 and pin 3 of U1; there should be a logic LO on pin 14 of U1.
- (d) Check to see whether K14 is closed--it should be.
- (e) Check for the presence of the BIT signal (~60 mV pk-pk) at the + side of C207. If the signal is not present, either the BIT Oscillator is not working or there is a short on the signal line--trace all the way back to J3 for shorts.
- (f) Check for the presence of the BIT signal (~60 mV pk-pk) at J8, pin 3.
- (g) Check for the presence of the BIT signal (~50-60 mV pk-pk) at K1, pin 5.
- (h) Check for the presence of the BIT signal (approximately 50-60 mV pk-pk) at J3. If the signal is not present here, but present everywhere else, K13 is probably open.

1A1A5-2 through 1A1A5-6

One of these fault codes indicates that the BIT Oscillator signal failed to pass through a specific filter (the fault code corresponds to the number of the filter; for example, 1A1A5-4 corresponds to filter 4). The fact that 1A1A5-1 was not declared indicates that all the common circuitry is good. Therefore, the problem must be in the specific filter or the relays controlling it.

- (1) Manually activate the BIT Oscillator by moving the jumper on J7 from pins 1 and 2 to pins 2 and 3.
- (2) Set the transceiver to a frequency in the faulty band. Refer to the following chart:

<u>Band</u>	<u>Frequency range</u>
2	2.6 - 4.19999 Mhz

3	4.2 - 6.79999 MHz
4	6.8 - 10.99999 MHz
5	11.0 - 17.99999 MHz
6	18.0 - 29.99999 MHz

- (3) Visually check to see whether the associated relays at either end of the suspected filter are energized. Use the following chart:

<u>Filter</u>	<u>Input relay</u>	<u>Output relay</u>
2	K8	K2
3	K9	K3
4	K10	K4
5	K11	K5
6	K12	K6

- (4) If both relays do not energize, check the control line for the suspected filter and the associated relay driver (U1).
- (5) If the relays energize, signal trace the suspected filter. Signal strength should be approximately 50-60 mV pk-pk.

1A1A5-7

This fault code indicates that one set of filter relays remained stuck in the energized position after being commanded off. (The BIT circuitry checked for the presence of the test signal at the Receive BIT Detector after all the filters were deselected.) The following procedure manually checks the operation of each set of relays.

- (1) On the front panel of the transceiver, step through all six frequency bands. As you change from one band to the next, visually check to see that the proper set of relays deenergizes and the proper set of relays energizes. Use the following chart and the component location drawing (figure 6-6) for the Low Pass Filter PWB Assy.

<u>Filter Band</u>	<u>Frequency Range</u>	<u>Relays Energized</u>
1	1.6 - 2.59999 MHz	K1, K7
2	2.6 - 4.19999 MHz	K2, K8
3	4.2 - 6.79999 MHz	K3, K9
4	6.8 - 10.99999 MHz	K4, K10
5	11.0 - 17.99999 MHz	K5, K11
6	18.0 - 29.99999 MHz	K6, K12



- (2) For example, when switching from a frequency in Band 2 to one in Band 3, relays K2 and K8 should deenergize (contacts open), and relays K3 and K9 should energize (contacts close).
- (3) When you find the set of relays that does not open when it is supposed to, check the control line and driver circuitry for that set.

1A1A5-8

This fault code occurs during the transmit phase of the BIT test. From a comparison of the voltages at J6 (V REFL, V FWD), the test determines whether the VSWR is abnormally high.

- (1) Check that K13 (the transmit/receive relay) energizes when you key the transceiver.
- (2) If K13 does not function properly, check the T/R Relay Control circuit.
- (3) Disconnect the cable at J2 on the Low Pass Filter PWB Assy. Insert a T-connector between J2 and a dummy load. Connect the other end of the T-connector to an RF voltmeter.
- (4) Set the transceiver for AME mode.
- (5) Key the transceiver with no modulation.
- (6) Check for ~35 Vac on the RF voltmeter.
- (7) If there is no power output, check for a short between J1 and K13 or between J2 and K14.
- (8) If you do get the required amount of power out, check the Directional Coupler circuit (secondary side of T1). This circuit is evidently sending out erroneous information to the BIT circuitry via J6.

1A1A5-9

This fault code indicates that there is no power out of the Low Pass Filter PWB Assy in transmit.

Troubleshoot this fault code the same way as fault code 1A1A5-8.

6-10. AGC/TGC PWB ASSY, A1A6.

a. Preliminary Procedure.

- (1) Remove the good AGC/TGC PWB Assy from the test-bed 100 Watt Transceiver, and replace it with the faulty AGC/TGC PWB Assy.
- (2) Connect a dummy load to the output (J1) of the transceiver.
- (3) Power up the transceiver.
- (4) Check for the presence of the following power supply voltages on the board. Voltages should be within 0.5 V of the nominal value, except for the +10 Vdc, which should be within 0.25 V of the nominal value.

<u>Voltage:</u>	<u>Measure at:</u>
+5 Vdc	+ side of C6
+15 Vdc	+ side of C7
+15A	+ side of C62
-15 Vdc	- side of C8
-15A	- side of C64
+10 Vdc	AR3 pin 1

- (5) If the voltages check good, run the receive-transmit BIT test.

b. Interpreting the BIT Codes. Use the fault codes listed below as a guide in troubleshooting the AGC/TGC PWB Assy. Refer to the section corresponding to the fault code you get. Note that the fault codes are divided into two groups: AGC fault codes and TGC fault codes. This is because the AGC and TGC are completely different and separate functions. They have nothing to do with each other except for their use of the same power supply voltages. In the event that the test runs without generating a fault code, start at the beginning of the following procedures and work your way through to the end.

BIT Test Description for the  
AGC/TGC PWB Assy

AGC Section (Receive Portion of the BIT Test)

- (1) Checks signal strength (looks for 16-19 segments on the "S" meter) in USB at maximum RF gain with the BIT Oscillator (on the Low Pass Filter PWB Assy) activated.
- (2) Checks signal strength in USB at maximum RF gain with the BIT Oscillator not activated.
- (3) Checks signal strength in USB at minimum RF gain with the BIT Oscillator activated.

TGC Section (Transmit Portion of the BIT Test)

- (4) Keys the transceiver in CW mode.
- (5) Verifies the correct transceiver output power level.
- (6) Verifies that the TGC system has stabilized at a normal control level.

AGC Fault Codes

1A1A6-1

This fault code indicates that the AGC voltage is too high.

- (1) Rotate the RF gain control on the front panel of the transceiver fully clockwise.
- (2) Disconnect the antenna from the transceiver so that no signal is coming in.
- (3) Check the following test points for the indicated voltages. (Measurements should be taken with the medium AGC speed selected.)

<u>Test Point</u>	<u>Voltage (+/- 0.5 Vdc)</u>
TP11 (AGC threshold)	-7 Vdc
TP12 (AGC delay)	0 Vdc
TP13 (combined AGC)	0 Vdc
TP15 (2nd IF AGC)	0 Vdc
TP16 (1st IF AGC)	-6 Vdc
TP17 (RF AGC)	0 Vdc

Record your readings.

- (4) On the Low Pass Filter PWB Assy, manually activate the BIT Oscillator by placing the

jumper on J7 into the test position (pin 2 to pin 3).

- (5) Select 2.456 MHz USB on the transceiver.
- (6) Check the test points again, and compare the results with the values listed below:

<u>Test Point</u>	<u>Voltage (+/- 0.5 Vdc)</u>
TP11 (AGC threshold)	+6.6 Vdc
TP12 (AGC delay)	+6.6 Vdc
TP13 (combined AGC)	+6.6 Vdc
TP15 (2nd IF AGC)	-3.8 Vdc
P16 (1st IF AGC)	+5.3 Vdc
TP17 (RF AGC)	0 Vdc

Record your readings.

- (7) Use the test point readings to isolate the problem.

A1A1A6-2

This fault code indicates that there is no manual RF gain control; that is, the AGC voltages do not vary correctly as the sensitivity of the transceiver goes from maximum to minimum.

- (1) Rotate the RF GAIN control on the front panel of the transceiver fully clockwise.
- (2) Disconnect the antenna from the transceiver so that no signal is coming in.
- (3) Measure the voltage at TP13. It should be 0 Vdc.
- (4) Rotate the RF GAIN control fully counterclockwise. The voltage at TP13 should now be approximately +9.6 Vdc or more.
- (5) If this is not the case, check AR22A and its associated circuitry.

1A1A7-4

This fault code indicates that the AGC set point is bad.

Perform the AGC Threshold Adjustment (R167). If the fault persists, troubleshoot this fault code the same way as fault code 1A1A6-1.

TGC Fault Codes

## 1A1A6-3

This fault code indicates that the TGC set point is incorrect, as indicated by an out-of-tolerance reading on the forward power meter. In other words, the microprocessor reads the voltage on pin 16 of J1, which is a buffered sample from the VSWR bridge on the Low Pass Filter PWB Assy, to determine whether the output power (and therefore the TGC set point) is correct.

The problem could be anywhere in the TGC circuitry. Refer to the flowchart (figure 6-18).

## 1A1A6-4

This fault code indicates that the TGC output voltage has not stabilized at a normal control level.

The problem could be anywhere in the TGC circuitry. Refer to the flowchart (figure 6-18).

## All Other Fault Codes

Normally, no fault codes other than the above should be declared during the TGC (transmit) portion of the BIT test. Therefore, when a fault code other than 1A1A6-3 or 1A1A6-4 is declared (when the AGC/TGC PWB Assy is known to be bad), the most likely suspects are the PPC circuitry and the output comparator (AR13B, Q10, and Q11).

Check the emitter of Q9 to ensure that it is at +2.7 Vdc +/- 200 mV. If the voltage is higher than that and the PPC LED is not lit, suspect a problem with Q9. If the PPC LED is lit, check out the PPC circuitry (see pages 1 and 2 of the flowchart).

**6-11. RECEIVER PWB ASSY, A1A7.**a. Preliminary Procedure.

- (1) Remove the good Receiver PWB Assy from the test-bed 100 Watt Transceiver, and replace it with the faulty Receiver PWB Assy.
- (2) Power up the transceiver.

- (3) Connect a dummy load to the transceiver.
- (4) Check for the presence of the following power supply voltages on the board. The voltages should be within 0.5 V of the nominal value.

<u>Voltage:</u>	<u>Measure at:</u>
+5 Vdc	+ side of C141
+15 Vdc	+ side of C4
-15 Vdc	- side of C142
+13.6 Vdc	+ side of C140
+15 V-R	+ side of C12 (in receive)
+15 V-T	+ side of C14 (in transmit)

- (5) If the voltages check good, run the receive-transmit BIT test.

- b. Interpreting the BIT Fault Codes. Use the fault codes listed below as a guide in troubleshooting the Receiver PWB Assy. Refer to the section corresponding to the fault code you get. In the event that the BIT test runs without generating a fault code, look for other obvious symptoms, such as no speaker audio or no sidetone. Then refer to the "ADDITIONAL SYMPTOMS" section following the BIT code sections.

## BIT Test Description for the Receiver PWB Assy

1. Checks for the presence of the board by sending data to the board and receiving the MCB loop back bit in return.
2. Disables the speaker by turning on Q27 and disables the LINE output by turning off CR38.
3. Activates the BIT Oscillator and verifies the presence of 455 KHz IF at J2 (output to IF Filter PWB Assy).
4. Bypasses the volume and squelch controls, sets the RF gain to maximum, and verifies that no LINE audio is present in USB.
5. Activates the BIT Oscillator and verifies the presence of LINE audio.
6. In transmit, verifies the presence of 455 KHz IF at J2 (output to IF Filter PWB Assy).

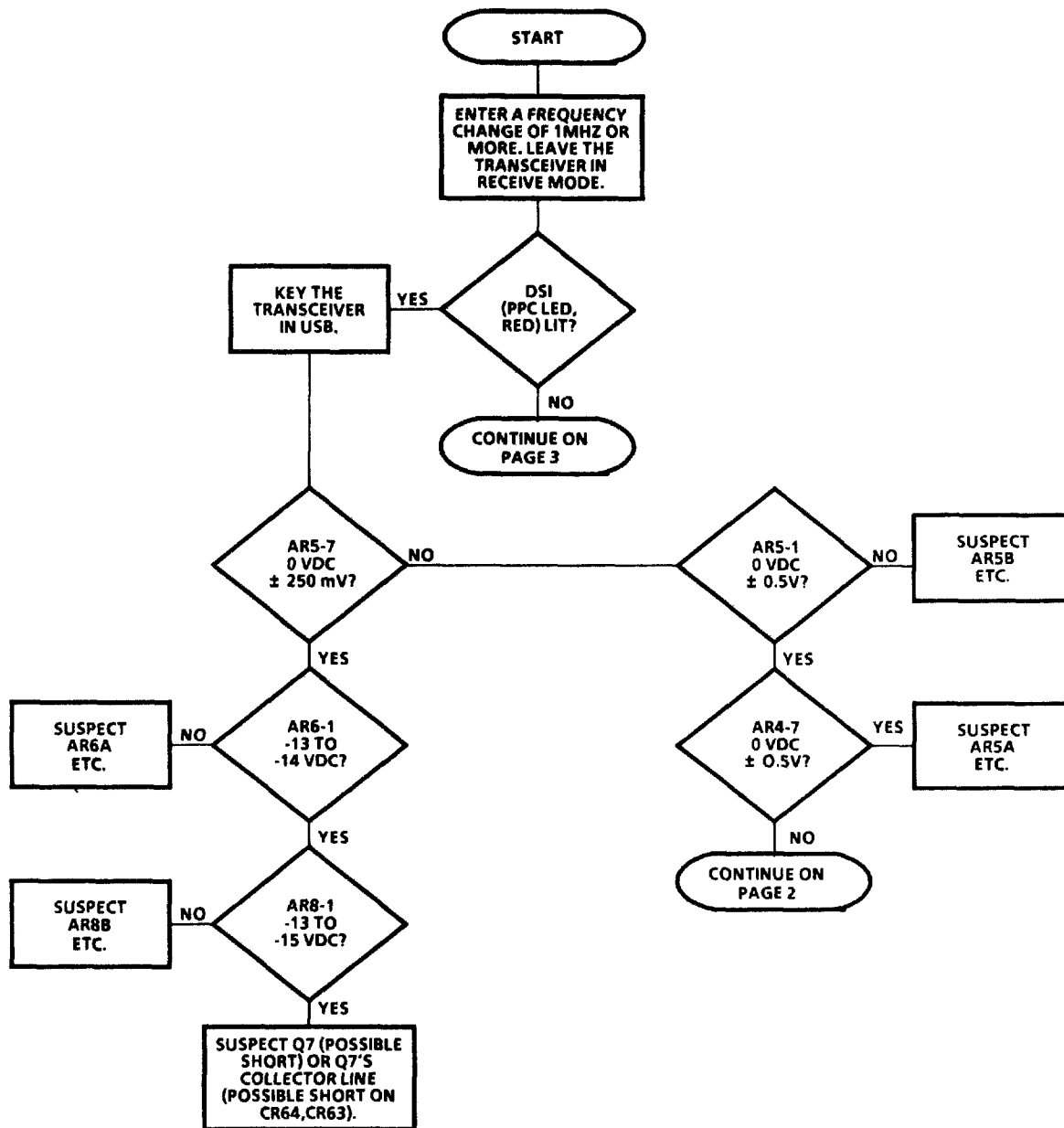

\*350-135-1

Figure 6-18. TGC Fault Isolation Chart (Page 1 of 15)

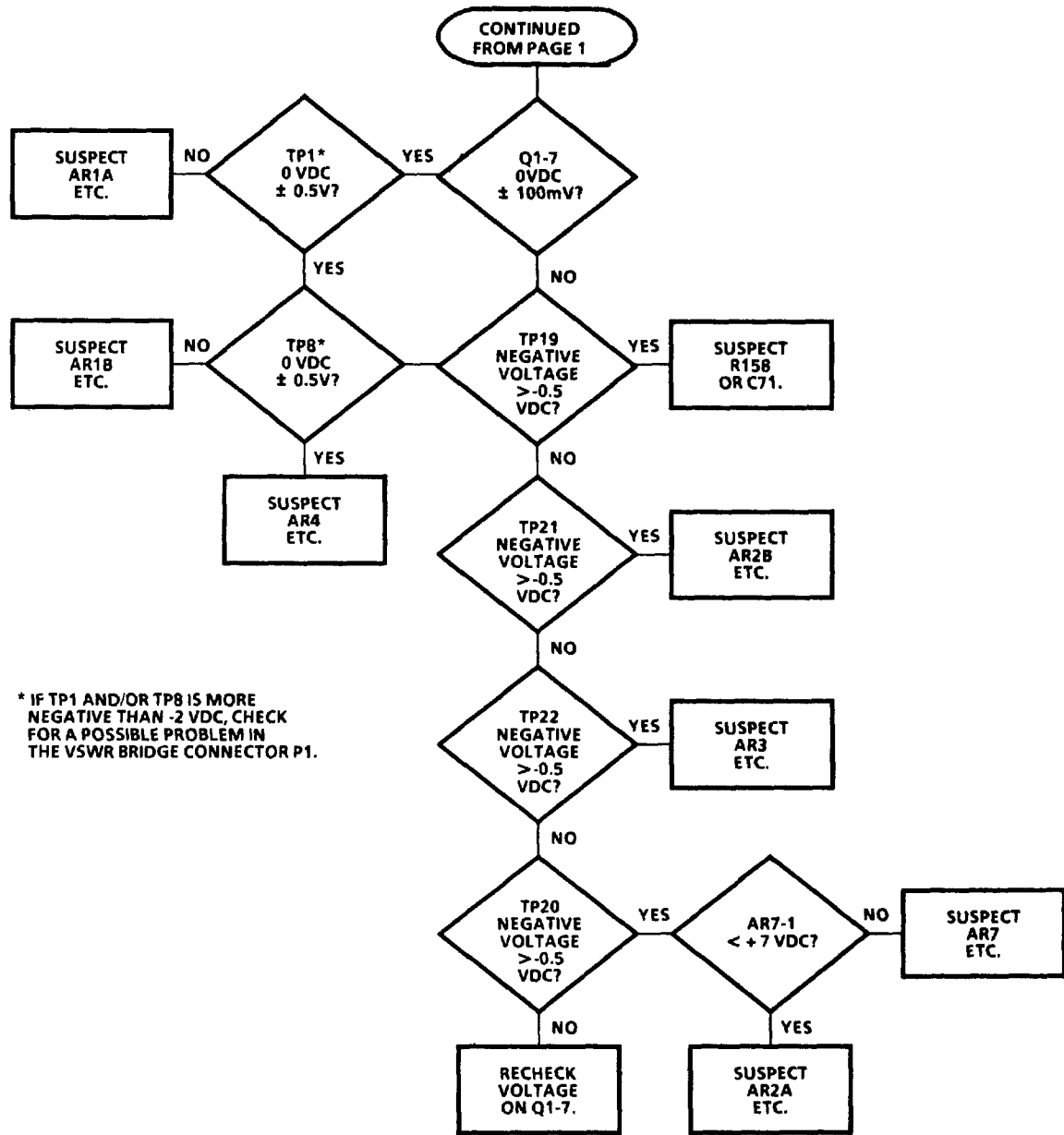

\*350-135-2

Figure 6-18. TGC Fault Isolation Chart (Page 2 of 15)

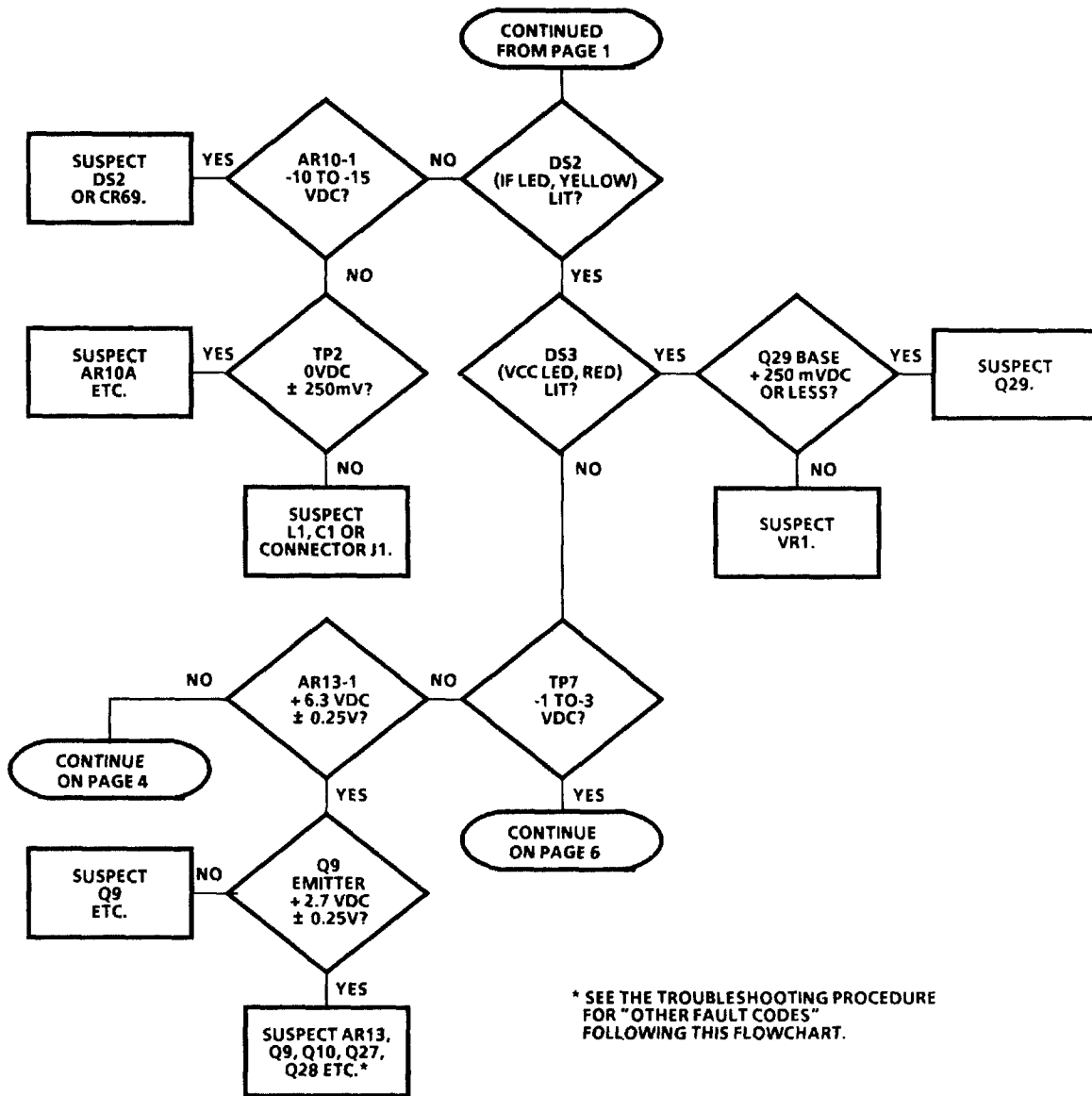

\*350-135-3

Figure 6-18. TGC Fault Isolation Chart (Page 3 of 15)

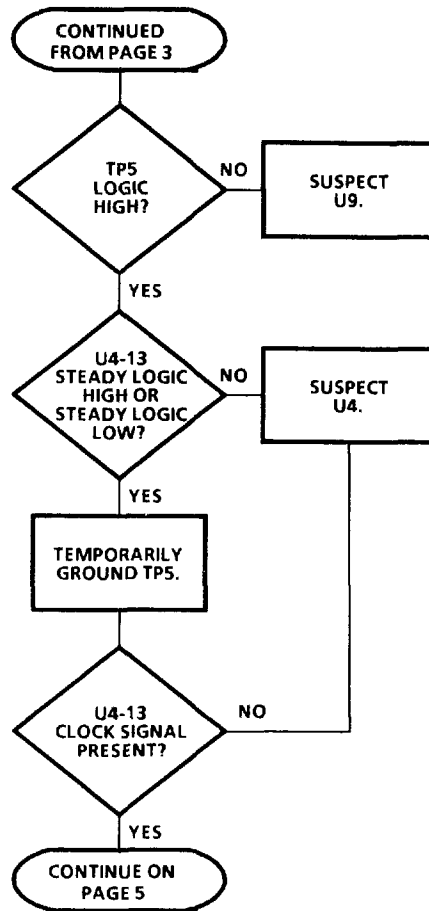

\*350-135-4

Figure 6-18. TGC Fault Isolation Chart (Page 4 of 15)

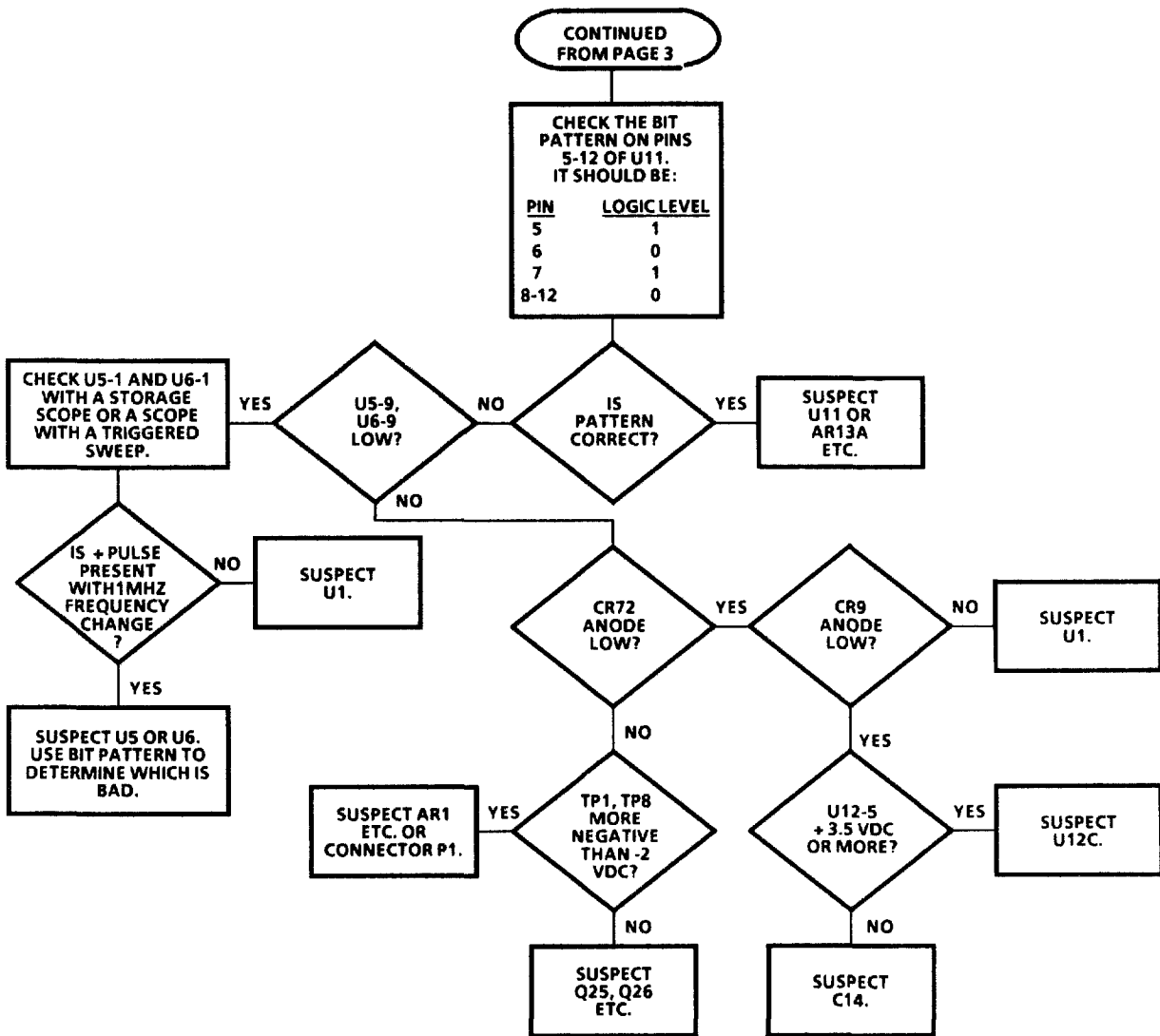

\*350-135-5

Figure 6-18. TGC Fault Isolation Chart (Page 5 of 15)



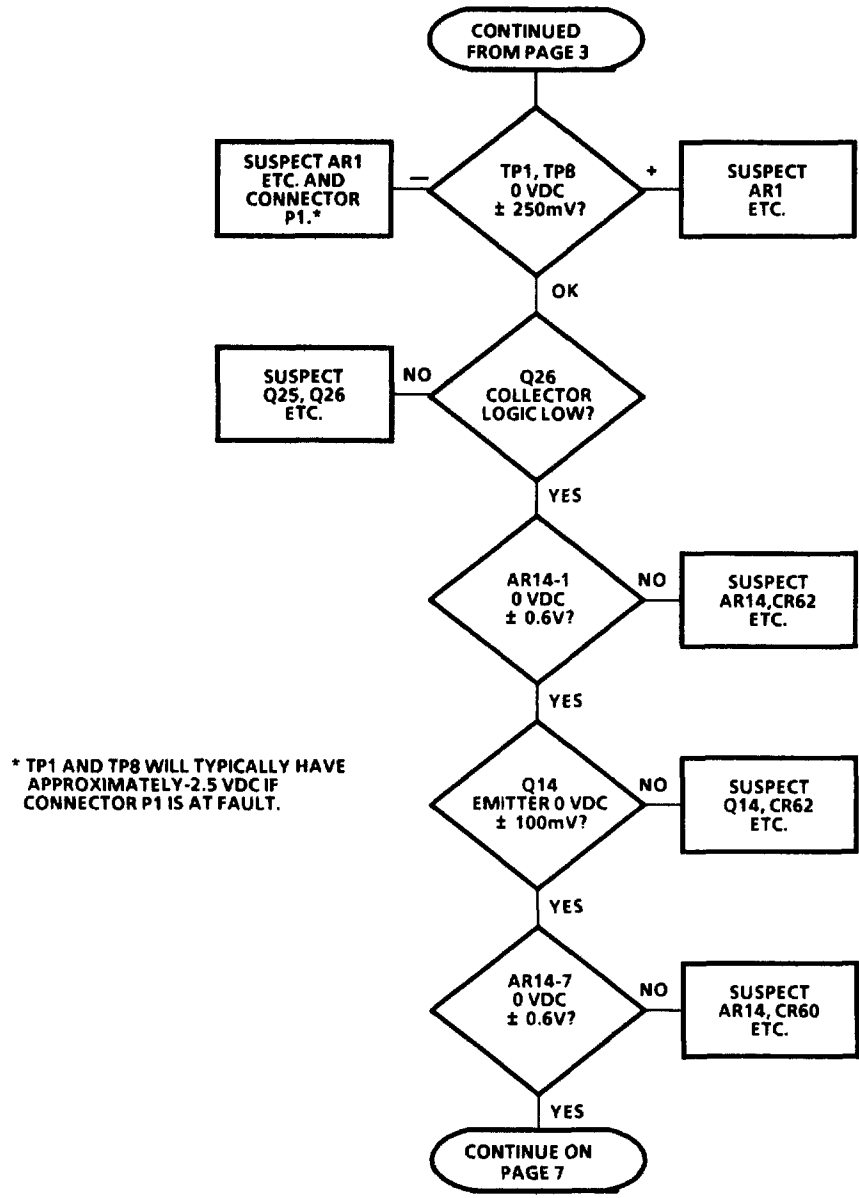

\*350-135-6

Figure 6-18. TGC Fault Isolation Chart (Page 6 of 15)

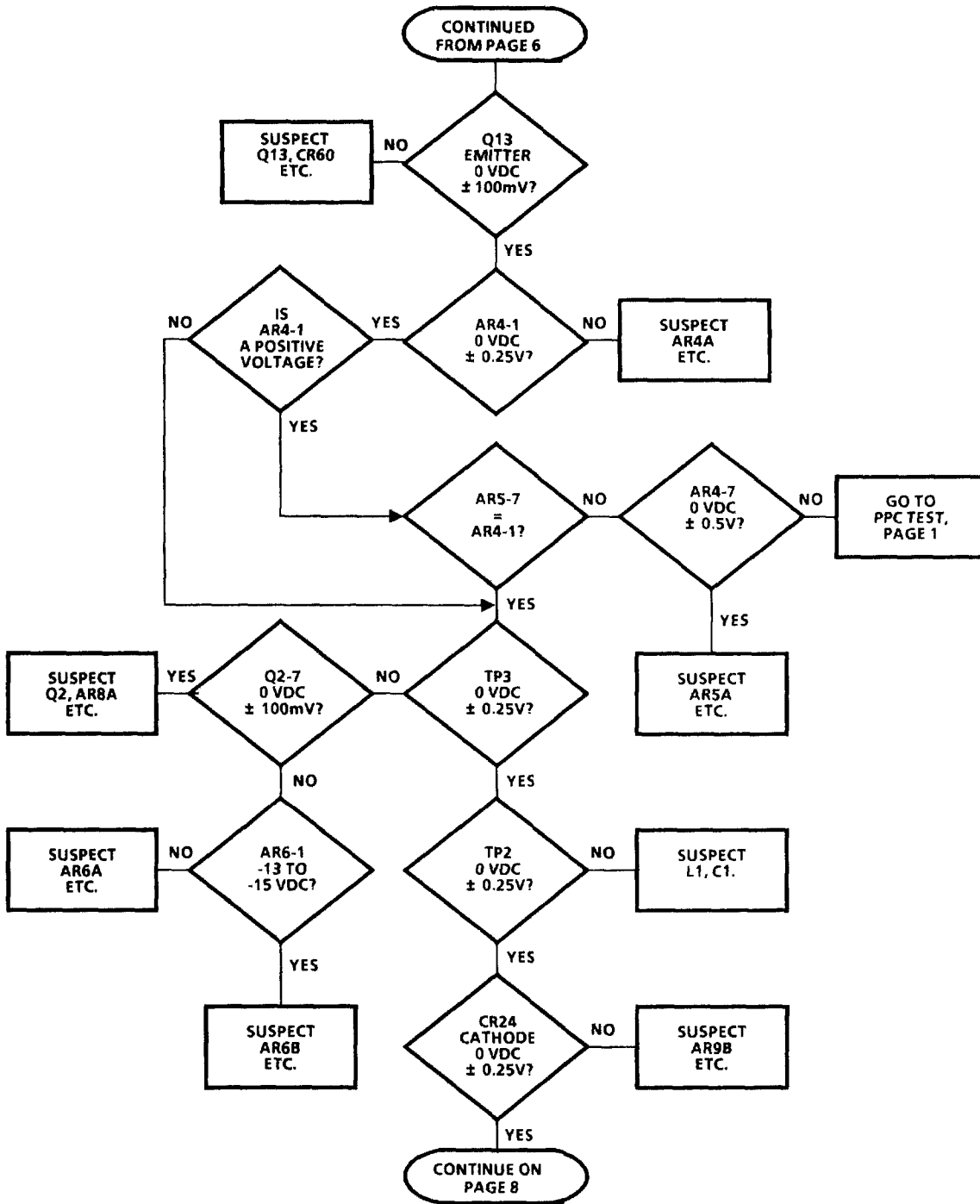

\*350-135-7

Figure 6-18. TGC Fault Isolation Chart (Page 7 of 15)

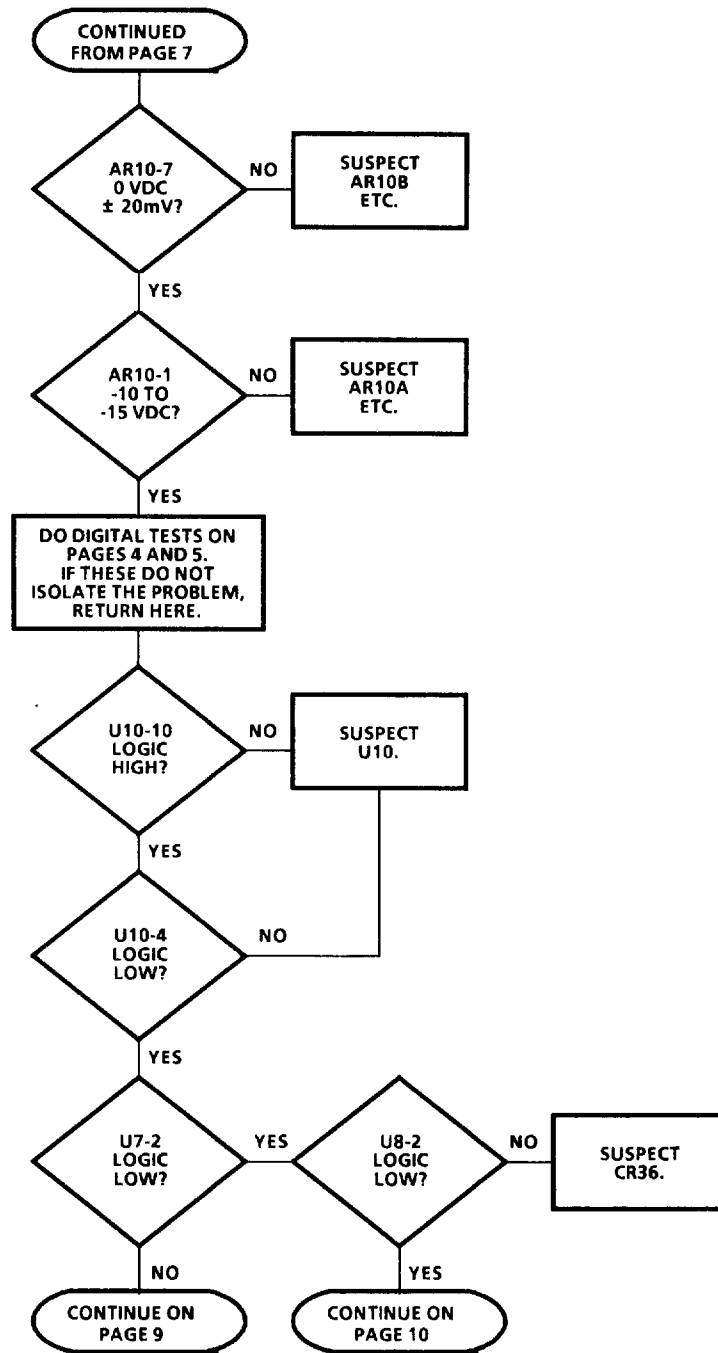

\*350-135-8

Figure 6-18. TGC Fault Isolation Chart (Page 8 of 15)

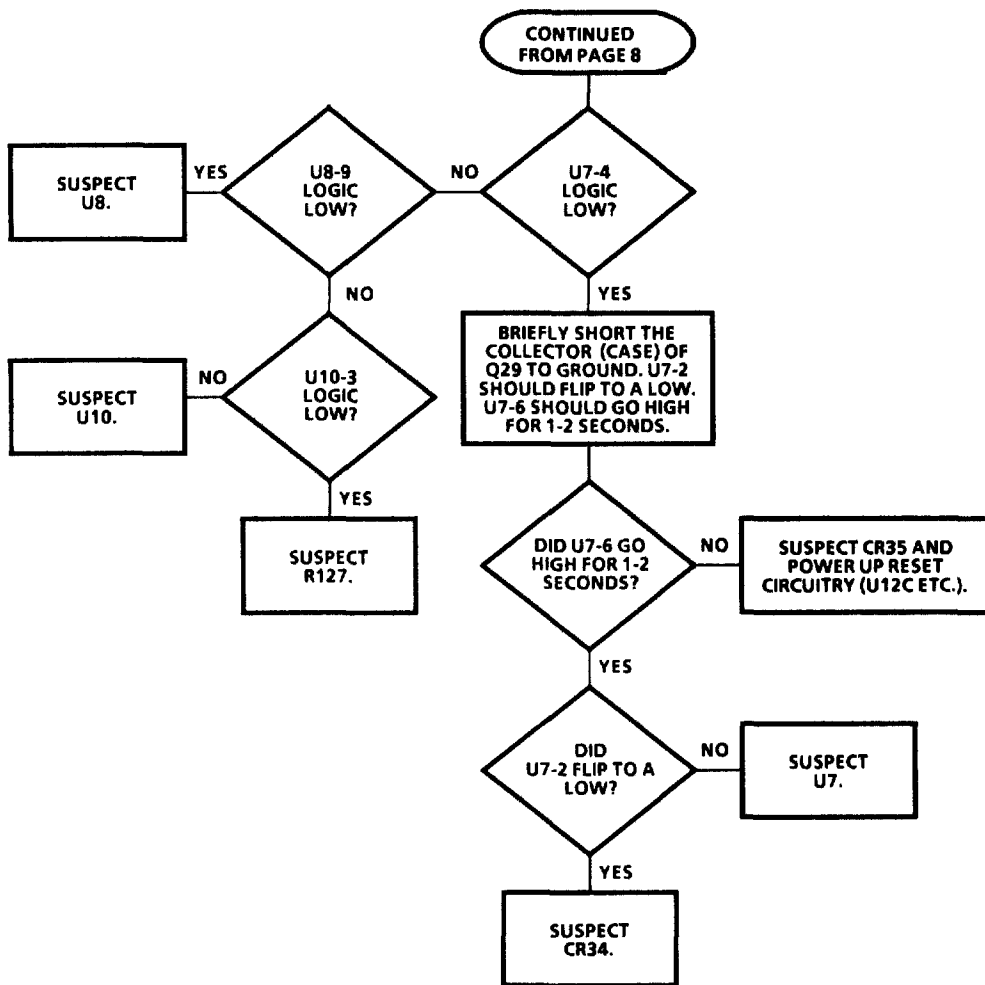

\*350-135-9

Figure 6-18. TGC Fault Isolation Chart (Page 9 of 15)

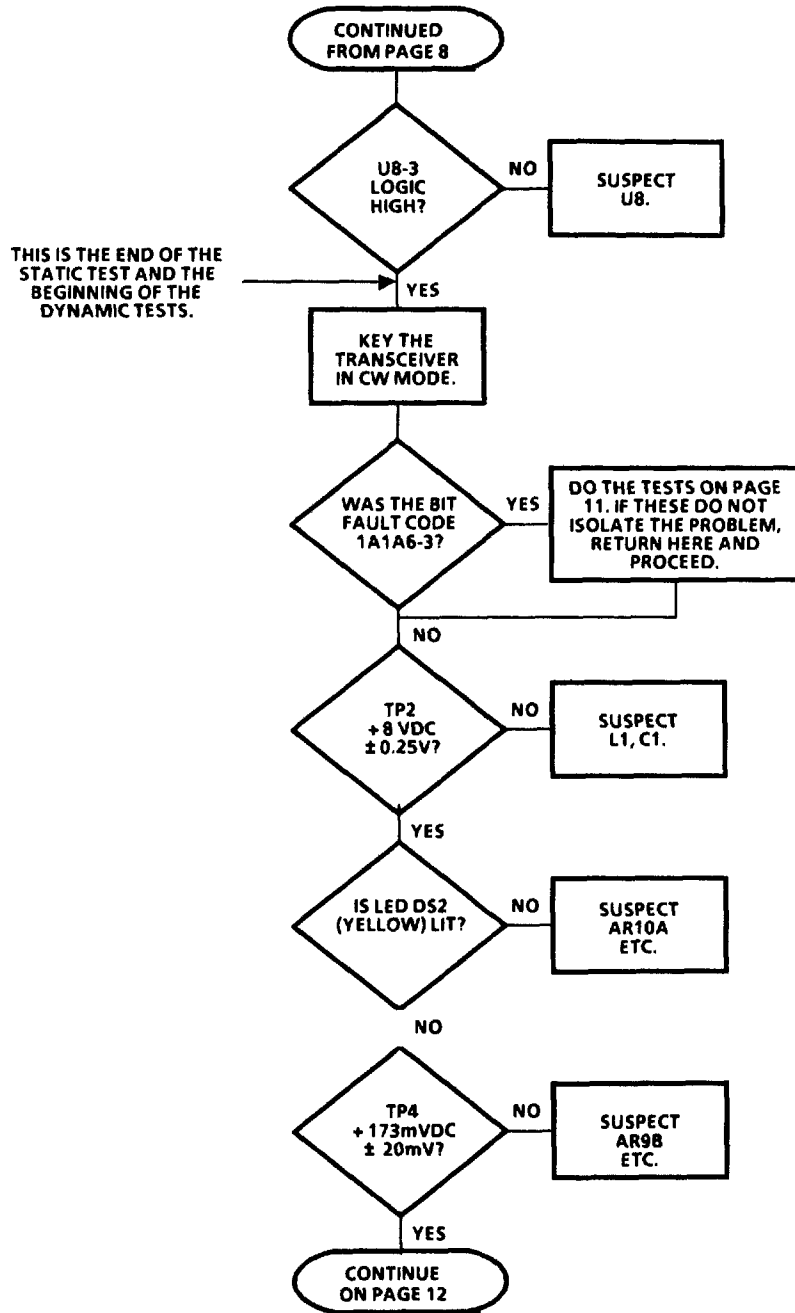

\*350-135-10

Figure 6-18. TGC Fault Isolation Chart (Page 10 of 15)

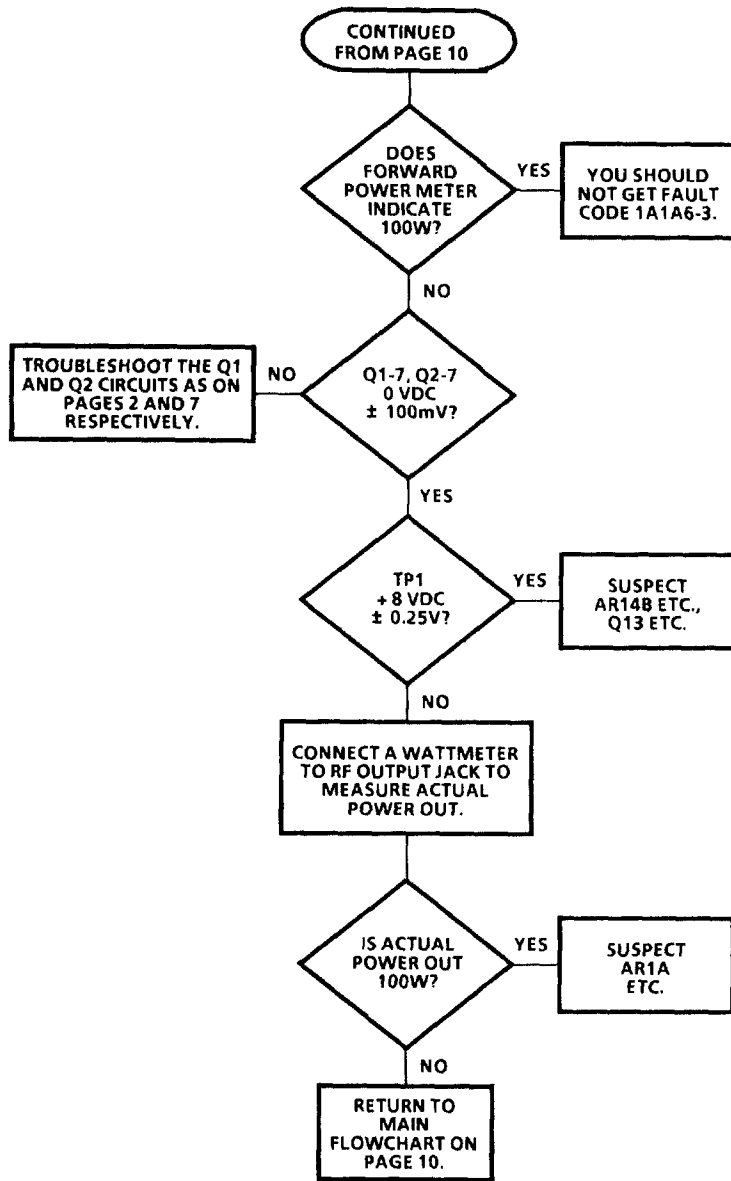

\*350-135-11

Figure 6-18. TGC Fault Isolation Chart (Page 11 of 15)

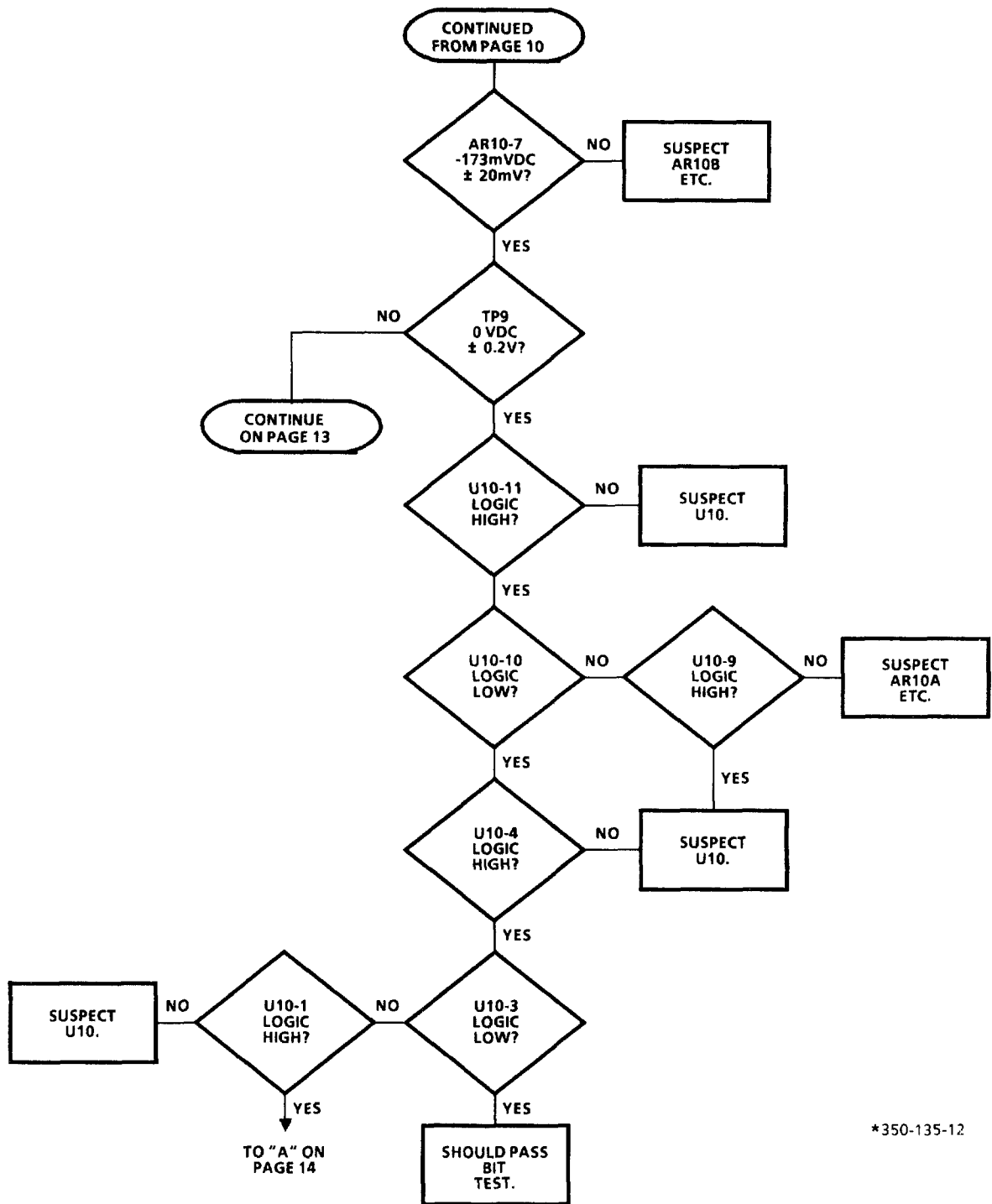

\*350-135-12

Figure 6-18. TGC Fault Isolation Chart (Page 12 of 15)

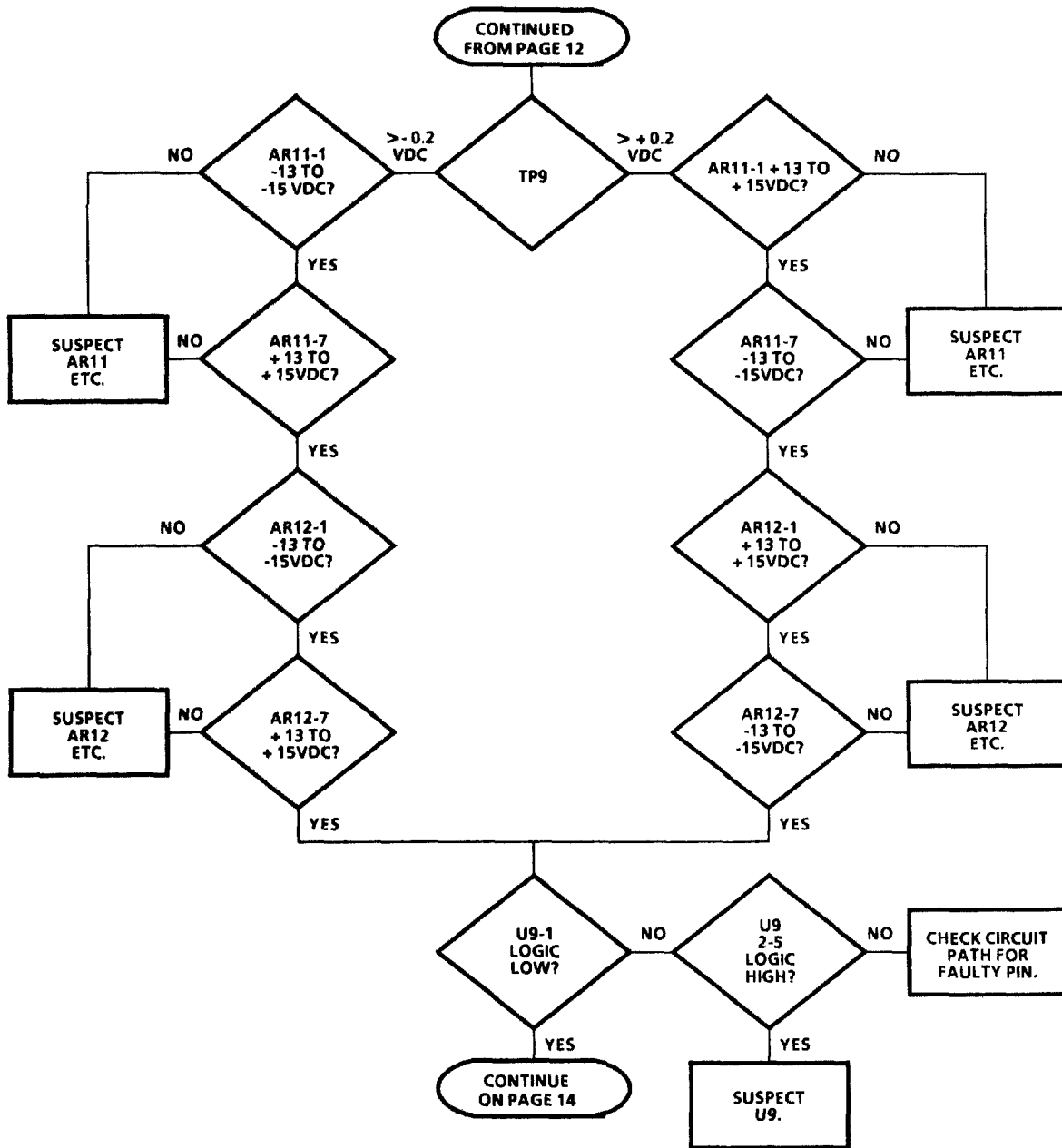

\*350-135-13

Figure 6-18. TGC Fault Isolation Chart (Page 13 of 15)



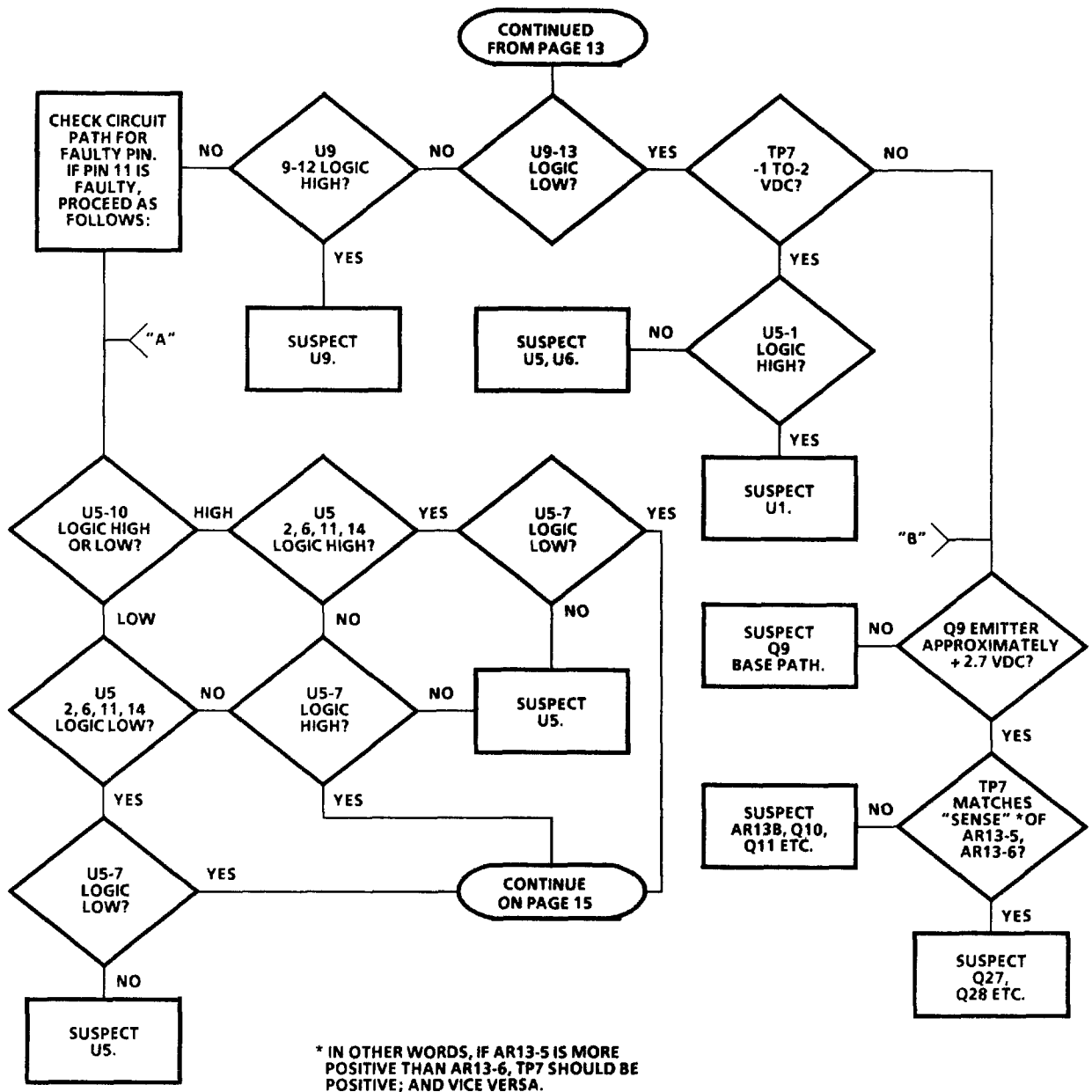

\*350-135-14

Figure 6-18. TGC Fault Isolation Chart (Page 14 of 15)

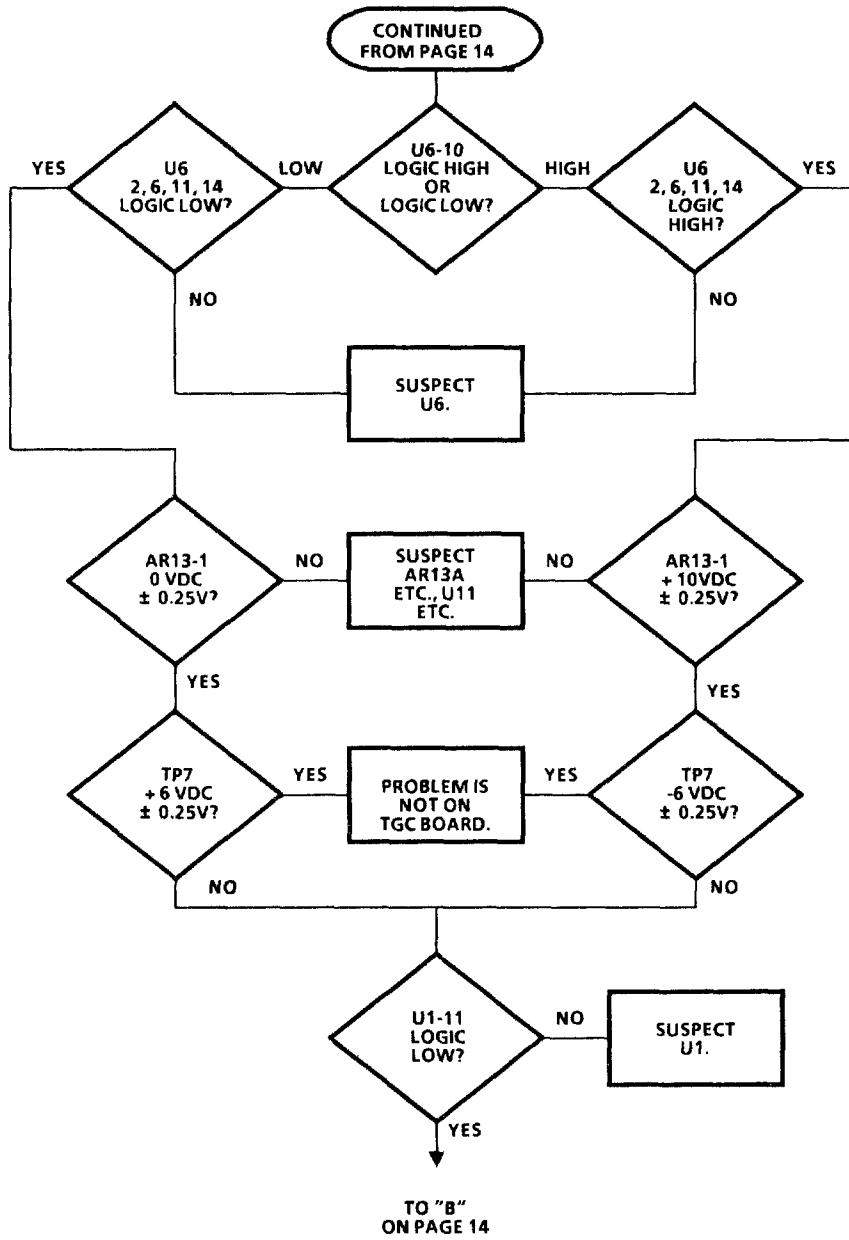

\*350-135-15

Figure 6-18. TGC Fault Isolation Chart (Page 15 of 15)

## 1A1A7-0

This fault code indicates that the microprocessor sent data to the Receiver PWB Assy but did not receive the MCB loop back bit in return.

The fault has to be in the MCB loop back circuitry (U23, U22A, U18, U19, U20, U22E, U22F) or the clock circuitry (U22B, U22D).

- (1) Check pin 11 of U19 with an oscilloscope. This pin should go momentarily high (MCB loop back bit) at the beginning of the BIT test.
- (2) If not, check U19, U18, U22A, and U23. Check also the RF CLOCK signal (625 KHz) at U22B and U22D.
- (3) If the MCB loop back bit is good at pin 11 of U19, check U20, U22F, and U22E.

## 1A1A7-1

This fault code indicates that the receive 2nd IF signal was not detected at J2 (the output to the IF Filter PWB Assy).

- (1) Check the BIT Detector circuit as follows:
  - (a) Inject a 40.455 MHz signal at -40 dBm into J1.
  - (b) Connect a spectrum analyzer to J2.
  - (c) You should see a 455 KHz signal at -36 dBm (or greater).
  - (d) If the signal is good, then the BIT Detector (Q5, Q6, and their associated components) is bad.
  - (e) If the signal is bad, proceed to step 2.
- (2) Check that CR3 is forward biased and that CR4 is reverse biased. If this is not the case, troubleshoot the pin diode T/R switch circuitry (CR3, CR4, R7, R8, R14, C21, C23). If the diodes are biased correctly, proceed to step 3.
- (3) Check the junction of L19 and pin 8 of U1 with an oscilloscope. You should see a 40 MHz signal at least 1 V pk-pk in amplitude. If

not, the problem is in the LO Amplifier Q4 and its associated circuitry. If the signal is good, proceed to step 4.

- (4) Check that CR2 is forward biased by more than 0.5 V and that CR1 is not forward biased by more than 0.4 V. If not, troubleshoot the Attenuator circuit (CR1, CR2, R1, R2, C2, L1, L3, R5, C5, R4, R3, and CR37). If the diodes are correctly biased, proceed to step 5.
- (5) The problem is either in the IF Amplifier (Q1 and its associated components) or in the Mixer (U1 and its associated components). Try replacing Q1 and U1 and/or signal tracing (this may be difficult due to the low signal level).

## 1A1A7-2

This fault code indicates that a low LINE level was detected at the output of AR9A (pin 1).

- (1) Troubleshoot the signal path as follows:
  - (a) Select AME mode on the transceiver front panel.
  - (b) Select AGC OFF.
  - (c) Inject a 454 KHz, -80 dBm signal at J5.
  - (d) Connect an oscilloscope to TP1. You should see a 454 KHz signal at 35 mV pk-pk.
  - (e) If not, check the biasing of the pin diodes: CR7 should be forward biased, and CR8 should be reverse biased. If the diodes are incorrectly biased, troubleshoot the T/R switch circuitry (CR7, CR8, R10, C38, R31, R9, C39). If the diodes are correctly biased, troubleshoot the IF Amplifier (Q8-Q11).
  - (f) If the signal at TP1 is good, proceed to step 2.
- (2) Select USB on the transceiver front panel and do the following:

- (a) Connect the oscilloscope to TP2. You should see a 1 KHz audio signal at an amplitude of 200-400 mV pk-pk.
- (b) If not, check the collector (case) of Q13 with the oscilloscope. You should see a 455 KHz signal at approximately 4.4 V pk-pk. If this signal is bad, the BFO Amplifier (Q7, Q13, and their associated components) is at fault.
- (c) If the signal at Q13 is good, the problem is in the Buffer Amplifier (Q12 and its surrounding circuitry), Mixer U2, or the Audio Amplifier (AR1 and its associated components).

(3) If TP2 is good, do the following:

- (a) Check the audio signal at pin 4 of U4 with the oscilloscope. It should be the same as at TP2.
- (b) If not, U4 is probably bad.
- (c) Check for the same audio signal at pin 15 of U5. If it is not there, U15 or its associated circuitry is probably bad.
- (d) If the signal is good at U15, then the problem is in AR3B or AR9.

**NOTE**

When troubleshooting this area, make sure that the front panel LINE potentiometer is not set for minimum output. Otherwise, you won't get any signal indication.

**1A1A7-3**

This fault code indicates that the pin diode T/R switch (CR3, CR4) at the J2 output is faulty.

- (1) Put the transceiver in the transmit mode with the 2ND, TX KEY buttons on the front panel.
- (2) Check the biasing of CR3 and CR4: CR3 should be reverse biased, and CR4 should be forward biased. If not, check the diodes and their associated components (R8, C23, C21, R7, R14).

- (3) If the diodes are correctly biased, the problem has to be a bad connector (J3) or a bad circuit board trace.

**1A1A7-4**

This fault code indicates that there is a problem with the AGC voltage. Since we can assume that our AGC/TGC PWB Assy is good and that our Receiver PWB Assy is bad, the problem has to be in either the AM Detector (where the AGC voltage originates) or the two AGC attenuators (CR1, CR2 or CR9-CR11).

- (1) Check the AM Detector as follows:
  - (a) Select AGC OFF on the transceiver front panel.
  - (b) Inject a 454 KHz, -80 dBm signal at J5.
  - (c) Check the junction of R85 and the emitter of Q16 with a DC voltmeter. You should see approximately +0.25 Vdc.
  - (d) Increase the output of the signal generator to -74 dBm.
  - (e) Check the voltage at the emitter of Q16 again. It should have increased to +0.5 Vdc.
  - (f) If the voltage in either case is bad, the problem is in the AM Detector (Q14-Q16 and their associated components).

- (2) If the voltages at Q16 are good, then the problem is in one of the AGC attenuators: CR1, CR2, and their associated components; or CR9-CR11 and their associated components.

**1A1A1-2**

This fault code indicates that the pin diode T/R switch (CR7, CR8) at the J5 input is faulty.

- (1) Put the transceiver in the transmit mode with the 2ND, TX KEY buttons on the front panel.

- (2) Check the biasing of CR7 and CR8: CR7 should be reverse biased, and CR8 should be forward biased. If not, check the diodes and their associated components (R10, C38, R31, R9, C39).
- (3) If the diodes are correctly biased, the problem has to be a bad connector (J6) or a bad circuit board trace.

1A1A6-2

This fault code indicates that one of the AGC attenuators is not functioning properly.

Check the CR1, CR2 AGC Attenuator and its associated components (C2, L1, R2, L3, R1, R5, C5, R4, CR37, R3) and the CR9-CR11 AGC Attenuator and its associated components (C42, R32, R37, C44, R197, C48, R47, C53, R51).

ADDITIONAL SYMPTOMS

The above fault codes cover the main signal path, but there are several other circuits on the Receiver PWB Assy that could cause problems. However, these circuits are readily identified by the following obvious symptoms:

No Sidetone

Check AR2B, U4A, and their associated components.

Bad PATCH Audio Output

Check AR10B and its associated components.

Bad NBSV Audio Output

Check AR10A, Q25, and their associated components.

No Speaker Audio

Check AR11, U5C, and their associated components.

No Headphone Audio

Check AR8B and its associated components.

No Speaker or Headphone Audio

Check U5A, AR12A, and their associated components. There could also be a problem in the squelch circuitry, which causes U5A to open the audio line to the speaker and headphone.

Incorrect SQUELCH Operation

Check the operation of the SQUELCH circuitry as follows:

- (1) Connect an RF signal generator to the antenna jack (J1) at the rear of the transceiver.
- (2) Select LSB on the transceiver at a frequency of 5 MHz.
- (3) Set the signal generator carrier frequency to 4.999 MHz at -20 dBm.
- (4) Manually adjust the SQUELCH control on the transceiver front panel, and check to see that the speaker audio is squelched as you rotate the control clockwise. Adjust the control so that the audio just squelches.
- (5) Modulate the carrier frequency with a 20 Hz signal at 50% modulation.
- (6) The squelch should break.

If the SQUELCH circuitry does not respond as described above, do the following:

- (7) Leaving the signal generator set up as before (with 50% modulation), connect a DC voltmeter to pin 2 of AR6A. You should see a positive DC voltage which varies in proportion to the increase or decrease in the percentage of modulation on the signal generator. If the voltage here is good, skip to step 9. If not, continue with step 8.
- (8) Check the base of Q20 for a 1 KHz audio signal modulated at 20 Hz. If the signal is not good there, the problem is in the Audio Compressor circuit (AR4A, Q19, Q20, and their associated components). If the signal

is good, check for a 20 Hz audio signal at the output of the Bandpass Filter, AR5A pin 1. If this signal is not good, the problem is in the Rectifier (AR4B and its associated components) or the Bandpass Filter (AR5A and its associated components). If the signal is good at AR5A pin 1, then the problem is in rectifier AR5B or its associated components.

- (9) Check the inputs to Comparator AR6B, pins 5 and 6. The voltage at pin 5 is determined by the setting of the SQUELCH control. With a DC voltmeter, check that this voltage varies as you adjust the SQUELCH control. The voltage on pin 6 should vary as you adjust the percentage of modulation on the signal generator. If it does not, DC Amplifier AR6A (or its associated components) is probably bad. When the voltage at pin 6 becomes more positive than the voltage at pin 5, then the output at pin 7 should go low. This is the un-squelched condition. When the voltage at pin 5 is more positive than at pin 6, pin 7 should go high. This is the squelched condition. If the output at pin 7 does not behave as described, then the problem is in AR6B.
- (10) If the output of Comparator AR6B is good, then the problem has to be in the diodes CR19, CR20, or in Buffer Amplifier AR7B (or their associated components). You can also check the SQUELCH MONITOR line at pin 11 of switch U5A. This line should be low during the un-squelched condition and high during the squelched condition.

**6-12. CRYSTAL OSCILLATOR ASSEMBLY, A1A8.** There is no troubleshooting procedure for the Crystal Oscillator Assembly. The purpose of the following procedures is (1) to determine whether the Crystal Oscillator Assembly is functioning properly; and, if it is found to be off-frequency, (2) to attempt to adjust the frequency to the specified value.

a. Output Check.

- (1) Disconnect the power cable for the Crystal Oscillator Assembly in the test-bed transceiver (this cable plugs into J12 on the Interconnect PWB Assy). In its place, connect the power cable for the Crystal

Oscillator Assembly you are testing. It is not necessary to mount this Crystal Oscillator Assembly in the transceiver.

- (2) Turn on the transceiver, and check the supply voltages at pins E1, E2, and E3 of the Crystal Oscillator Assembly. These voltages should be within 0.5 V of the nominal value.

E1,	+15 Vdc
E2,	0 Vdc
E3,	+13.6 Vdc

- (3) Obtain an SMB female to BNC adapter cable of 18 inches (or less) in length. Connect the SMB female end to the Crystal Oscillator Assembly, and connect the BNC end to an oscilloscope.
- (4) Check for a 10 MHz sine wave on the oscilloscope with an amplitude of 0.6 to 1.0 V pk-pk.
- (5) If you do not get this signal, the Crystal Oscillator Assembly is defective and should be discarded. If the signal looks good, proceed to the frequency check below.

b. Frequency Check.

- (1) Disconnect the adapter cable from the oscilloscope, and connect it to a frequency counter. The frequency counter should be referenced to a frequency source whose stability is better than 1 part in 10 per day.
- (2) Check that the frequency of the Crystal Oscillator Assembly is 10.000000 (+/- the offset, if specified on the label) MHz.

**NOTE**

Some Crystal Oscillator Assemblies may have an offset. The reason for this offset is to enable the Crystal Oscillator Assembly to meet the temperature stability specification, which demands that the frequency not vary more than 3.3 Hz from the nominal value over the entire temperature range (-30 to +75 C). For example, the Crystal Oscillator Assembly may have to be set for a room-temperature (25 C) frequency of 10.000001 MHz in order to meet

the temperature stability specification. In this case, the offset would be +1 Hz.

- (3) If the frequency is not correct, do the adjustment procedure for the Crystal Oscillator Assembly (see Section II, Alignment Procedures).

**6-13. REFERENCE/BFO PWB ASSY, A1A9.**

a. Preliminary Procedure.

- (1) Remove the good Reference/BFO PWB Assy from the test-bed 100 Watt Transceiver, and replace it with the faulty Reference/BFO PWB Assy.
- (2) Power up the transceiver.
- (3) Connect a dummy load to the transceiver.
- (4) Check for the presence of the following power supply voltages on the board:

<u>Voltage:</u>	<u>Measure at:</u>
+5 V-A	+ side of C82
+5 V-B	+ side of C83
+5 V-C	+ side of C65
+15 V	+ side of C66

- (5) If the voltages check good, run the receive-transmit BIT test.

- b. Interpreting the BIT Fault Codes. Use the fault codes listed below as a guide in troubleshooting the Reference/BFO PWB Assy. Refer to the section corresponding to the fault code you get. In the event that the test runs without generating a fault code, start at the beginning of the following procedures and work your way through to the end.

BIT Test Description for the  
Reference/BFO PWB Assy

- 1. Verifies the presence of the 1 KHz, 455 KHz (nominal), and 40 MHz outputs from the board.
- 2. Verifies the frequency lock of the BFO at both ends of the frequency range.

**NOTE**

If the BFO is out of lock, the FAULT light on the transceiver front panel illuminates. This happens independently of the BIT test. For this reason, BFO unlock is referred to as a "run-time fault," since the BIT test does not have to be run for the FAULT light to come on.

1A1A9-1

FAULT light illuminates without BIT  
(run-time fault)

In this case, the FAULT light came on as soon as the transceiver was powered up (and before the BIT test was run). Therefore, this fault code indicates that there is a problem in the phase lock loop circuitry.

- (1) Check to see whether the BFO is really out of lock as follows:
  - (a) Check for a low at the collector of Q9, which is the RF ATTN line. If Q9's collector is low, which it should be during a BFO unlock condition, then the collector of Q7 should be high.
  - (b) If the collector of Q7 is not high, then look for a problem in the Q9 area (possible Q9 collector-to-emitter short, for example).
  - (c) If the collector of Q9 is low and the collector of Q7 is high, connect a frequency counter to the junction of R58 and R59. (To access R58 and R59, you must remove the shield from the VCO Assembly.)
  - (d) Center-tune the BFO by going to USB or LSB receive mode and leaving the BFO key on the transceiver front panel deactivated.
  - (e) The frequency displayed on the frequency counter should be 45.500 MHz. If it is not, the BFO is unlocked; and the problem is in the phase lock loop circuitry. Proceed to step 2.

- (2) Check the phase lock loop circuitry as follows:
  - (a) If you have not already done so, remove the shield from the VCO on the Reference/BFO PWB Assy.
  - (b) Look at TP2 with an oscilloscope. You should see a positive DC voltage (at 6.5 Vdc) with no AC component. If TP2 is good, skip to step 3. If not, proceed to step c.
  - (c) If TP2 is bad, check the VO and RO outputs of U5 (pins 8 and 7, respectively).
    - i. In the locked condition (when the reference frequency = the variable frequency), VO and RO should be logic high with a series of low-going pulses (approximately 1 us wide) spaced 1 ms apart.
    - ii. In the unlocked condition (when the reference frequency is either higher or lower than the variable frequency), both VO and RO should be square waves. These square waves will be approximately opposite to each other; that is, when VO is negative, RO is positive and vice versa.
  - (d) Connect a voltmeter to TP1. If RO is low more than it is high, the voltage at TP1 should approach the +15 V supply. If VO is low more than it is high, the voltage at TP1 should approach 0. (In the locked condition, TP1 should be approximately +6.5 Vdc.)
  - (e) If the voltage at TP1 is in accord with the VO and RO signals at the output of U5, proceed to step 3. If not, trace the VO and RO signals through U6 and Q11-Q13.
- (3) Check the VCO as follows:
  - (a) Center-tune the BFO (see step 1d above).
  - (b) Unsolder one end of R54.
    - (c) Connect the positive lead of a DC power supply to TP2 and the negative lead to the VCO shield.
    - (d) Connect a frequency counter to the junction of R58 and R59.
    - (e) Adjust the power supply for +4 Vdc at TP2. The frequency counter should read approximately 40 MHz.
    - (f) Increase the voltage to 6.5. The frequency counter should now read 45.5 MHz.
    - (g) Increase the voltage to 9.6. The frequency counter should read approximately 50 MHz.
    - (h) If the VCO performs as described above, proceed to step 4. If not, decrease the power supply voltage to 6.5 and adjust C35 for 45.500 MHz on the frequency counter. Then repeat steps e-h. If the VCO still does not function correctly, troubleshoot the internal VCO circuitry.
- (4) Check the inputs to U5 as follows:
  - (a) Adjust the power supply output to 6.5 Vdc, and verify that the output frequency of the VCO is 45.500 MHz. Connect the frequency counter to pin 12 of U8 (or pin 1 of U5), and check for a frequency of 910 KHz. Replace the frequency counter with an oscilloscope, and check for a TTL (0-5 V) square wave with a 20% duty cycle (signal should be high 20% of the time). If the signal is good, proceed to step b. If not, trace the signal back through U8-2 (4.55 MHz), U7-15 (45.5 MHz), and the source of Q15 (45.5 MHz).
  - (b) Check for an 8 KHz TTL square wave at pin 27 of U5. If this signal is good, replace U5. If not, trace the 8 KHz line back to U12.



1A1A9-1

FAULT light does not illuminate until BIT test is run.

Since the FAULT light did not illuminate until after the BIT test was run, this fault code indicates that the phase lock loop circuitry is working properly. The problem is that one of the three output frequencies (1 KHz, 455 KHz, or 40 MHz) is incorrect or missing.

The first thing to do is check the BIT Detector circuit as follows:

- (1) Verify that the collector of Q8 is low (this is the fault condition).
- (2) Check the voltage on the base of Q6. Under normal conditions (no fault), the voltage here should be the same as on the emitter (+5 Vdc), indicating that Q6 is not conducting. If this is the case, then the problem is in the BIT Detector (Q6, Q5, and their associated components).
- (3) If Q6 is biased to conduct (base voltage is less than the emitter voltage), then check the cathodes of CR17, CR23, and CR27 to determine which of these diodes is conducting. Once you know which of these diodes is on, you know which circuit to troubleshoot:

Conducting diode:    Faulty circuit:

CR17	40 MHz
CR23	455 KHz (BFO/Carrier)
CR27	1 KHz

Refer to the appropriate troubleshooting section below.

40 MHz

- (1) Check the gate (case) of Q3 for a 40 MHz sine wave at 1.2 V pk-pk. If the signal here is good, then the problem is in the BIT Detector (Q3, Q4, and their associated components). If the signal here is the correct frequency but low, you might try adjusting L1 and L2 to get more output. Refer to the alignments section.

- (2) If the signal at the gate of Q3 is bad, check pin 3 of U14 for a 10 MHz TTL (0-5 Vdc) square wave. If this signal is bad, then the problem is probably U14 (since the circuitry prior to U14 is common to the other two frequency outputs, which we know are good).
- (3) If the signal at pin 3 of U14 is good, the problem is in the multiplier circuitry (Q1, Q2, and their associated components). Check the collector of Q2 (not the case) for a distorted 40 MHz sine wave (the sine wave should be "ringing" at a 10 MHz rate) at 4.5 V pk-pk (maximum), and work your way backwards or forwards from this point.

455 KHz (BFO/Carrier)

**NOTE**

The BFO/Carrier BIT amplifier (Q19) is normally off. It is turned on only during the BIT test.

- (1) Check the gate (case) of Q18 for a 455 KHz (+/- 1 KHz) sine wave at 1 V pk-pk. If the signal here is good, the problem is in the BIT Detector (Q18, Q19, and their associated components).
- (2) If the signal at the gate of Q18 is bad, check the collector of Q17 for a 455 KHz (+/- 1 KHz) square wave at 0-5 V pk-pk. If the signal here is good, the problem is in the 455 KHz Filter (C47-C53 and L6). If not, proceed to step 3.
- (3) Check for a TTL (0-5 Vdc) square wave at the output of U9 (pin 2). If the signal is bad here, check for a sine wave at the input (pin 7). If the input is good, replace U9. (The input to U9 should be good. Otherwise, the BFO would be out of lock, since the same signal is applied to the phase lock loop circuitry.)

1 KHz

- (1) Check pin 1 of AR1 for a 1 KHz sine wave at 4.2 V pk-pk. If the signal here is good, then the problem is probably in the 1 KHz BIT Detector (Q10 and its associated components). To verify this, check the

collector of Q10. The voltage here should be within 0.2 to 0.4 V of the emitter voltage.

- (2) If the signal at AR1 pin 1 is bad, check at E2 for a 1 KHz TTL (0-5 Vdc) square wave. If the signal is good here, the 1 KHz Filter (AR1 and its associated components) is probably bad.
- (3) If the signal is bad at E2, verify that a 200 KHz TTL square wave is coming out of U11 pin 3. (U11 should be good, since the 200 KHz reference to the Synthesizer originates here. If this signal was absent, fault code 1A1A10-1 would be declared.) Then trace the signal through U12 and U13, noting that its frequency gets divided down in successive stages until it becomes 1 KHz at pin 9 of U13.

1A1A10-1  
 FAULT light illuminates without BIT  
 (run-time fault)

This fault code indicates that there is a problem with the 200 KHz reference signal originating on the Reference/BFO PWB Assy, since without this the Synthesizer cannot lock (which is the reason why a Synthesizer fault code is displayed).

- (1) Check the output of P2 on the Reference/BFO PWB Assy for a 200 KHz TTL (0-5 Vdc) square wave.
- (2) Work your way back through U11, U14, Q22, and Q21, all the way to the 10 MHz input from the Crystal Oscillator Assembly at J2 (the signal level here should be a 10 MHz sine wave at 0.5 to 1 V pk-pk). The signal level at the source of Q21 should be a little less than at J2, and the signal at the collector of Q22B should be the 10 MHz TTL (0-5 Vdc) square wave (the signal is changed from a sine wave to a square wave in Q22).

**6-14. SYNTHESIZER PWB ASSY, A1A10.**

a. Preliminary Procedure.

- (1) Remove the good Synthesizer PWB Assy from the test-bed 100 Watt Transceiver,

and replace it with the faulty Synthesizer PWB Assy.

- (2) Power up the transceiver.
- (3) Check for the presence of the following power supply voltages on the board. Voltages should be within 0.5 V of the nominal value.

<u>Voltage:</u>	<u>Measure at:</u>
+15 V-A	+ side of C2
+15 V-B	+ side of C63
+5 V-A	+ side of C6
+5 V-B	+ side of C67
-15 Vdc	- side of C72

- (4) If the voltages check good, run the receive-only BIT test. Refer to the section corresponding to the fault code you get.

b. Interpreting the BIT Fault Codes. Use the fault codes listed below as a guide in troubleshooting the Synthesizer PWB Assy. In the event that the test runs without generating a fault code, start at the beginning of the following procedures and work your way through to the end.

BIT Test Description for  
the Synthesizer PWB Assy

- 1 - Verifies the presence of the Synthesizer PWB Assy by sending data to it and receiving data back.
- 2 - Verifies the presence of the Synthesizer output and frequency lock at both ends of the tuning range.

1A1A10-0

This fault code indicates that the microprocessor did not receive a response (the MCB loopback bit) when it sent data to the Synthesizer PWB Assy.

- (1) Check the cable going to J3 on the Synthesizer PWB Assy.
- (2) Connect an oscilloscope to pin 11 of U7 (this is where the MCB loopback bit originates).

- (3) Run the receive-only BIT test and verify that pin 11 of 7 changes state. This change of state is the MCB loopback bit which is fed on the RF DATA line via U2 and U3 to pin 10 of J3 and from there back to the microprocessor.
- (4) If no change of state occurs, check the data, clock, and strobe lines into U5, U6, and U7.

**NOTE**

The strobe pulse may be very difficult to see without a storage scope. At the inputs to shift registers U5, U6, and U7, the strobe pulse is a positive-going signal of 1.5 to 2.0 usec in width; at the input (pin 1) and output (pin 15) of U1, the strobe pulse is a negative-going signal, which is inverted by Q45 before being applied to U5, U6, and U7. The strobe signal is what causes pin 11 of U7 to change state after all the data bits have been clocked into U5, U6, and U7.

1A1A10-1

This fault code indicates that the Synthesizer is out of lock.

- (1) Disconnect the coax cable from J5 on the First Converter PWB Assy (this cable originates at P1 on the VCO), and connect it to the RF input of the spectrum analyzer.
- (2) Adjust the spectrum analyzer to scan from 0 to 110 MHz, with the top vertical line on the analyzer display equal to +10 dBm.
- (3) Set the test-bed transceiver for USB at a frequency of 1.64500 MHz. (This sets the Synthesizer frequency to 42.10000 Mhz.)
- (4) Connect the oscilloscope to TP3 on the Synthesizer PWB Assy. If the Synthesizer is operating properly, the voltage on TP3 should be +8.2 +/- 0.4 Vdc with no AC component.
- (5) While observing the voltage on TP3, also observe the spectrum analyzer display.

Case 1: The Synthesizer frequency is less than 35 MHz, and the

voltage on TP3 is greater than +11.5 Vdc.

**Conclusion:** The VCO is probably okay. The problem is most likely in the reference frequency signal path.

**Procedure:** Check for a 100 KHz signal (pulses) at pin 11 (or pin 5) of U19. If the signal is not there, work your way back through Q4 and U17A, which divides the 200 KHz reference coming in from J1.

Case 2: The Synthesizer frequency is greater than 70 MHz, and the voltage on TP3 is greater (more negative) than -6 Vdc.

**Conclusion:** The VCO may or may not contain the fault.

- Procedure:**
1. Check the VCO. See the procedure below.
  2. Check the Sample and Hold circuitry. See the procedure below.
  3. Check the Divide by N circuitry. See the procedure below.
  4. Check the Integrator circuitry. See the procedure below.

**SAMPLE AND HOLD  
Checkout Procedure**

1. Quick Check:
  - (a) Observe the voltage waveform on TP2. In a properly working Synthesizer, the waveform should appear as on page 7 of the schematic diagram.
  - (b) If TP2 indicates a pure DC level greater than +11.5 Vdc, and if TP3 is the same, then the Sample and Hold circuitry is probably okay.

(c) Similarly, if TP2 indicates a pure DC level greater (more negative) than -6 Vdc, and if TP3 is the same, then the Sample and Hold circuitry is probably okay.

(d) If neither (b) nor (c) is true, then perform the Detailed Checkout Procedure below.

2. Detailed Checkout Procedure:

(a) With an oscilloscope, check the voltage at pin 3 of AR2. This voltage should be the same as on pin 6, which is the same as TP3.

(b) Check the voltage on pin 2 of AR2, which should be the same as the voltage on pins 3 and 6.

(c) Check pin 11 of U5 for the SAMPLE CONTROL signal, which should be a series of positive pulses 280-500 ns wide at a frequency of 100 KHz (when the Synthesizer is in lock).

(d) Remove P1 from J7 and P2 from J8. This isolates the Sample and Hold circuitry.

(e) Connect a DC power supply to the circuit as follows: + lead to J7-2 (the pin closer to the VCO) and - lead to TP4 (GND).

(f) Connect the oscilloscope to TP3.

(g) Vary the power supply voltage from 0 to 10 Vdc. The waveform on TP3 should be a positive DC equal to the power supply voltage.

(h) Reverse the polarity of the power supply (+ lead to TP4 and - lead to J7-2).

(i) Vary the voltage as before. The voltage on TP3 should be a negative DC equal to the power supply voltage.

(j) If the SAMPLE CONTROL signal is good, but the Sample and Hold circuit does not respond properly to the

power supply voltage, the problem has to be in transistors Q20-Q27, op amp AR2, or their associated components.

VCO OSCILLATOR AND AMPLIFIER  
Checkout Procedure

1. Quick Check:

A quick and easy way to determine whether the VCO is the cause of a Synthesizer unlock condition is to substitute a known good VCO board for the one in the Synthesizer you are troubleshooting. If the Synthesizer functions correctly with the substitute VCO, then the original VCO is faulty; if not, then the problem is somewhere other than in the VCO.

2. Detailed Checkout Procedure:

(a) Remove jumper plug P2 from J8 on the Synthesizer PWB Assy.

(b) Remove jumper plug P3 from J5.

(c) Connect an RF voltmeter with a 50-ohm probe across pins 3 and 1 (GND) of J5.

(d) Disconnect the VCO output cable P1 from J5 on the First Converter PWB Assy. Using an SMB to BNC adapter, connect this cable to the input of a frequency counter.

(e) Connect the + lead of a DC power supply to J8-2 (pin 2 is the one closer to the VCO), and connect the - lead to TP4 (GND).

(f) Adjust the power supply for 8.2 Vdc. The frequency counter should read 42.10 +/- 2.1 MHz. The reading on the RF voltmeter should be 50 mV rms or greater.

(g) Reverse the polarity of the power supply leads.

(h) Adjust the power supply for 7.0 Vdc. The frequency counter reading should be greater than 70 MHz, and the RF voltmeter should indicate 50 mV rms or greater.

- (i) Disconnect the RF voltmeter.
- (j) Disconnect the VCO cable from the frequency counter, and connect it to the 50-ohm probe of the RF voltmeter.
- (k) The reading on the voltmeter should be between 0.45 V rms and 0.16 V rms as the power supply voltage is varied from 0 Vdc to 7 Vdc.

DIVIDE BY N  
Checkout Procedure

- (a) Remove jumper plug P3 from J5 on the Synthesizer PWB Assy.
- (b) Connect a coaxial test cable (Pomona Electronics 3787- C-36 or equivalent) to pins 1 (GND) and 2 of J5. Connect the BNC end of the test cable to the output jack on the rf signal generator.
- (c) Set the output frequency of the signal generator to 42.10000 MHz, and set the output level to -10 dBm.
- (d) Set the frequency of the test-bed transceiver to 1.64500 MHz, and set the mode to USB.
- (e) Connect a 24-pin DIP clip to U5, a 16-pin DIP clip to U15, and a 14-pin DIP clip to U14.
- (f) Connect a x10 oscilloscope probe to the 1 megohm input of a frequency counter.
- (g) Check the following pins with the oscilloscope probe:

U5-2  
U5-11  
U14-9  
U15-2  
U15-7  
U15-10  
U15-12  
U15-15

Each pin should have a frequency of 100.0 KHz.

- (h) Connect the x10 probe to an oscilloscope and monitor the waveform at U19-6. The waveform should be a series of extremely narrow pulses with a frequency of 100 KHz. The peak of the pulse should be greater than +4.0 Vdc, and the low level should be +3.3 Vdc or less.
- (i) Connect the probe to U19-11. This waveform should have the same characteristics as the one in the previous step.

INTEGRATOR  
Checkout and Troubleshooting Procedure

1. Checkout:

- (a) Set up the oscilloscope for two-channel operation.
- (b) Connect the probe for Channel 1 to TP2, which is the output of the Integrator.
- (c) Connect the probe for Channel 2 to the cathode of CR12, where you should see the DELAYED BIAS signal (refer to the Synthesizer Integrator Timing Diagram on figure FO-7 of the On-Equipment Manual, T.O. 31R2-2URC-81.)
- (d) As shown on the timing diagram, the voltage at TP2 should start to ramp down when the DELAYED BIAS signal goes high.

2. Troubleshooting:

We will consider the following two cases:

Case 1

The Integrator does not ramp down. The Integrator output is a steady DC voltage greater than +11.5.

- (a) Check the DELAYED BIAS signal at the cathode of CR12. This signal should go positive, as shown in the timing diagram FO-7 in the On-Equipment Manual,

T.O. 31R2-2URC-81. If not, the problem is in the DELAYED BIAS circuitry. Check the following:

- U15-3 (DELAYED BIAS)
- U15-2 (BIAS - should be one clock pulse (about 0.2 us) ahead of DELAYED BIAS)
- U5-9 (BIAS)
- U5-2 (CYCLE START - 100 KHz)
- U5-8 (VCO frequency/10)

If U5-2 and U5-8 are good, but U5-9 is bad, check the power supply pins of U5: U5-24 = +5 Vdc; U5-12 = 0 Vdc. Also check U5-17 (RESET), which is normally high. If these pins are all okay, replace U5.

- (b) Check the ramp-down current source as follows:

Q16, drain (should be a square wave, high for approximately 3.5 us, from -1.35 V to +0.4 V)

Q16, source (+5 +/- 0.25 Vdc)

Q19, source (+8.8 +/- 0.2 Vdc)

If the three voltages above are good, the problem is probably in the discrete-component op amp.

### Case 2

The Integrator output at TP2 is saturated at the negative DC supply voltage; i.e., greater (more negative) than -11.5 Vdc.

Connect the Channel 1 oscilloscope probe to TP2. Connect the Channel 2 oscilloscope probe to TP1. When TP1 goes negative to approximately -1.2 Vdc, the voltage at TP2 should start to ramp down as shown on page 7 of the Synthesizer schematic.

- (a) If TP1 does not go negative to -1.2 Vdc, then the problem is most likely between flip-flop U19 and TP1. With the oscilloscope, verify the signals at the following locations:

U19-2 (output, 100 KHz)

U19-3 (output, 100 KHz)

U19-6 (input, 100 KHz)

U19-11 (input, 100 KHz)

Verify the following power supply connections:

U19-1, -16 (+5 Vdc)

U19-8 (0 Vdc)

If the outputs of U19 are bad and all else is good, replace U19. If the outputs of U19 are good, the problem is between U19 and TP1.

- (b) If TP1 does go negative to -1.2 Vdc but the ramp (TP2) does not go up, then do the following:

While keeping one channel of the oscilloscope connected to TP2, check the waveform at the cathodes of CR3 and CR4 (refer to figure 6-19).

If the waveform is good, check the ramp-up current sink as follows:

- o Check the voltage at the gate (case) of Q11. This is the DELAYED BIAS signal voltage. For the ramp to go up, this voltage must be a low (Q11 not conducting).
- o If the gate of Q11 is high, check the DELAYED BIAS signal line from the collector of Q10 to U15-2 and back further if necessary (as in Case 1 above).
- o If the DELAYED BIAS signal line is okay, check the gate (case) of Q13, which should have a voltage of -6.2 Vdc with no AC component.
- o If this voltage is okay, check the voltage on U21- 15, which should be -8.8 Vdc with no AC component.

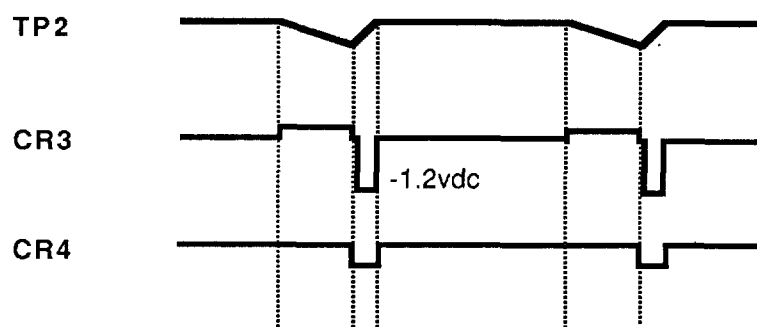

Figure 6-19. TP2 and the Cathodes of CR3, CR4

If none of the above voltages is bad, the problem is most likely inside the discrete-component op amp.

**6-15. FRONT PANEL PWB ASSY, A1A11A1.**

a. Preliminary Procedure.

- (1) You can check all the adjustment potentiometers and the speaker on/off switch without applying power to the Front Panel PWB Assy. If you don't know what the specific problem with the board is, begin by doing this.
- (2) Remove the good Front Panel Assembly (which consists of the Front Panel PWB Assy and the Display Assembly) from the test-bed 100 Watt Transceiver, and replace it with the faulty Front Panel PWB Assy. Remove the good Display Assembly from the test-bed Front Panel Assembly and attach it to the faulty Front Panel PWB Assy.
- (3) Power up the transceiver.
- (4) Check for the presence of the following power supply voltages on the board:

<u>Voltage:</u>	<u>Measure at:</u>
+5 Vdc	+ side of C2
+15 Vdc	+ side of C12
+12 Vdc	+ side of C13
+13.6 Vdc	+ side of C20

- (5) If the voltages check good, proceed to the next section, "Troubleshooting Procedures."

b. Troubleshooting Procedures.

- (1) If the Display Assembly is installed, check to see whether the backlights are functioning. If they are not, there is a problem with Inverter U8. Check for +13.6 V at the input terminals of the Inverter and 115 Vac 400 Hz at the output terminals.
- (2) If the Display Assembly is installed, check to see whether the outline of previous

segments persists when you change the segmental pattern by hitting a key. For example, when you change a particular digit from a "3" to a "1" and you can still see the outline of the "3," this indicates that there is a fault in the 60 Hz Oscillator, which consists of U5, R4, R5, and C10.

- (3) Check the operation of the FAULT LED DS1 by running the receive-only BIT test. The FAULT LED should come on when you run the test.
- (4) Troubleshoot the data path as follows:
  - (a) Press a key and check the bit pattern on pins 3, 4, and 11-14 on U4. Hit a different key and check the bit pattern again. The pattern should change every time you press a different key. If this is the case, then U2, U3D, and U9B are probably good. If not, compare pin 4 to the other five pins on U4. If pin 4 seems to behave properly and the others don't, then the problem is probably U2. If the reverse is true, then the problem is U3 or U9.
  - (b) Press and hold one of the scrolling keys--METER is a good choice. You should see continuous activity all along the main data path: continuous streams of pulses. Check the outputs of U4 (pin 9), U7A, U3B, U10D, and U12.
  - (c) You should also see continuous pulses on the three select lines coming out of U1 at pins 13, 14, and 15.
  - (d) Check for the presence of the 625 KHz FP CLOCK signal at pin 2 of U4, pin 5 of U3, and pin 12 of U10.
  - (e) Check that the clock line at pins 3 and 11 of U9 goes high and stays high as long as a key is held down.
  - (f) Check for a series of negative-going pulses on the FRONT PANEL ATTENTION line at the collector of Q1. Each pulse tells the microprocessor to read the key code from U4. One pulse is generated each time a key is



pressed; but when the key is held down, the pulses are continuous. The microprocessor responds by driving the KEYPAD-READ line low via U1 every time the key code is read, which results in a series of negative-going pulses corresponding to those on the FRONT PANEL ATTENTION LINE.

#### **6-16. REPAIR OF THE DISPLAY ASSEMBLY, A1A11A2.**

- a Place the Display Assy A1A11A2 up side down on the Guide Assy and insure that the two ends capacitors of the Display Assy are inserted into the cavities of the Guide Assy.
- b Unsolder the Back Light leads as required.
- c Slide the Bracket Retainer (P/N 10085-2112) out of the Display Assy.
- d Keep the Rubber Connector Trips (P/N 10085-5136) for possible reuse.
- e Replace the LCD, Back Light, and Connectors Trips as required. Insure to clean the contact surface between the Connectors Trips and the Crystal display with Isopropyl Alcohol and soft cloth.
- f Slide the Bracket retainer to it original position with the support of the Frame Assy. (Part of the Guide Assy)
- g Solder four Back Light leads.



## (1) Remarks.

The following drawings are needed to local manufacture the Guide Assy.

- |                   |             |
|-------------------|-------------|
| (a) Guide, Roller | Dwg# 20552  |
| (b) Frame,        | Dwg# 20554  |
| (c) Block         | Dwg # 20556 |
| (d) Frame, Assy   | Dwg # 20558 |
| (e) Base, Assy    | Dwg# 20553  |
| (f) Spacer        | Dwg# 20555  |
| (g) Bolt/Bearing  | Dwg# 20557  |
| (h) Guide, Assy   | Dwg# 20559  |

### 6-17. TRANSCEIVER CONTROL PWB ASSY, A1A12.

#### NOTE

The Transceiver Control PWB Assy contains the Intel 8088 microprocessor, which controls all the functions of the 100 Watt Transceiver, including the automatic BIT test. A failure in the microprocessor, EPROMs, RAMs, decoders, etc. will probably disable the BIT circuitry and most of the other transceiver functions as well. If the BIT circuitry is working, the only fault code associated with the Transceiver Control PWB Assy is 1A1A12-1, which indicates that there is a problem either with the power supply voltages (+15 Vdc and -15 Vdc) coming into the board or with the A/D Converter chip U7 that senses them. (The A/D Converter is used primarily with the metering and manual RF gain control circuitry. If it fails, it should not affect the essential functions of the transceiver, which are transmitting and receiving.) Unless you are thoroughly familiar with the circuitry of this board and with the operation of microprocessors, it will be very difficult for you to isolate a faulty chip or discrete component using standard test equipment and troubleshooting techniques. The following procedures, therefore, are intended to check only the most obvious and fundamental aspects of the board's

operation. If these do not enable you to identify the problem, then you will need more advanced test equipment and test procedures, which are beyond the scope of this manual.

#### a. Checkout and Troubleshooting Procedures.

- (1) Remove the good Transceiver Control PWB Assy from the test-bed 100 Watt Transceiver, and replace it with the fault Transceiver control PWB Assy.
- (2) Power up the transceiver.
- (3) Check the RESET signal at pin 21 of microprocessor U1. This pin should normally be low, but should go high when you push the reset button (S1).
  - (a) If the RESET signal is incorrect, check the reset circuitry: U41F, U10A, U10B, and U10C. Keep in mind that, in addition to the manual reset button, a RESET signal can be generated three other ways: (1) by a low voltage at TP1, which monitors the output of the +13.6 Vdc voltage divider circuit (if this voltage drops below +10 Vdc, a RESET will occur); (2) upon power-up, before the + input of U10C charges to a sufficient positive voltage to cause a high on pin 14, removing the RESET; and (3) by a low at pin 7 of U10B, which originates at pin 7 of the "Gone West Timer", U15. (The microprocessor must send a reset pulse to pin 1 of U15 every 13 ms, or U15 will generate a low at pin 7 after 65 ms, resetting the microprocessor. Check for negative-going reset pulses spaced 13 ms apart at pin 1 of U15.)
  - (b) If the RESET signal is okay, proceed to step 4.
- (4) Check the CLOCK input to the microprocessor by connecting an oscilloscope to pin 19. Check for a 5 MHz square wave.
  - (a) If the CLOCK signal is missing or incorrect, check pin 9 Divide-by-Counter U12. If the signal is bad there, check the output of the 15 MHz Oscillator at pin 1 of U12.

- (b) If the CLOCK signal is good, proceed to step 5.
- (5) Check for the presence of the following voltages on the Transceiver Control PWB Assy:
- | <u>Voltage:</u> | <u>Measure at:</u>                            |
|-----------------|---|
| +5 Vdc          | + side of C27                                 |
| +15 Vdc         | U39A, pin 8                                   |
| -15 Vdc         | U39A, pin 4                                   |
| +13.6 Vdc       | bottom of R3 (end away from potentiometer R2) |
- (6) Check the RAM disable line at pin 18 of U19 and U20. This line should normally be low, but should go high when you push the reset button. If this is not the case, check Bilateral Switch U14A. Pins 1 and 2 of this switch should be closed (at ground potential) when the microprocessor is not reset.
- (7) Check for +5 Vdc at pin 24 of U19 and U20 with the transceiver turned on. With the transceiver turned off, the voltage at pin 24 of U19 and U20 should slowly diminish to +3.6 Vdc as the battery voltage is switched in.
- (8) If all the above checks are good, replace microprocessor U1. (This chip is socketed for easy replacement.)
- (9) If the problem persists, replace the EPROMs, U16-U18, then the RAMs, U19 and U20. (These chips are also socketed.)
- (10) If the problem still persists, you can try checking the select lines to the EPROMs and RAMs from decoders U3 and U4A. One, and only one, of these lines should be low at any given time. If none of these lines goes low or if one or more lines are always low or if two or more go low at the same time, then there is a fault in the decoder.
- (11) You can also check the select lines to the I/O devices at pins 7 and 9-15 of decoder U5. These lines should behave exactly like the select lines in step 10.

- (12) As a final check, you can look at the clock signals on all the chips. Refer to the schematics for clock frequencies and pin locations.

### 6-18. LPA/COUPLER INTERFACE PWB ASSY, A1A13.

#### a. Preliminary Procedure.

- (1) Remove the good LPA/Coupler Interface PWB Assy from the test-bed 100 Watt Transceiver, and replace it with the faulty LPA/Coupler Interface PWB Assy.
- (2) Make sure that the transceiver is connected to a 100/500 Watt Antenna Coupler and a 500 Watt Linear Power Amplifier or to a 1000 Watt Antenna Coupler and a 1 KW Linear Power Amplifier. Make sure that the antenna coupler is connected to a dummy load capable of handling the output power of the power amplifier.
- (3) Power up the system.
- (4) Check for the presence of the two power supply voltages on the board:

<u>Voltage:</u>	<u>Measure at:</u>
+5 Vdc	+ side of C43
+13.6 Vdc	junction of R13, R18, and R21

- (5) If the voltages check good, run the receive-transmit BIT test.

- b. Interpreting the BIT Codes. Use the fault codes listed below as a guide in troubleshooting the LPA/Coupler Interface PWB Assy. In the event that the BIT test runs without generating a fault code, refer to the "Additional Symptoms" section following the fault code section.

#### BIT Test Description for LPA/Coupler Interface PWB Assy

The test checks for the presence of the board by sending data to the board and receiving the MCB loopback bit in reply.

## 1A1A1-1

This code indicates that there is a problem in the RF MUTE signal line.

- (1) With the system unkeyed, check for a high at pin 4 of U5B. Change the frequency on the transceiver by 1 MHz, then key the system. The voltage at pin 4 of U5B should go low, then high again.
- (2) If this is not the case, check L16, C25 (for a short), U17A, U5B, L1, C12 (for a short), U17C, R20, and U2D.
- (3) If pin 4 of U5B is good, check U17C and U2D.

## 1A1A13-0

This code indicates that the LPA/Coupler Interface PWB Assy did not respond to data from the Transceiver Control PWB Assy (did not send the MCB loopback bit).

Check the following components: U1, U5E, U8, U6, U9F. This is the signal path for the MCB loopback bit.

## ADDITIONAL SYMPTOMS

- (1) The LPA (Linear Power Amplifier) does not power up when commanded to by the 100 Watt Transceiver.

Check the LPA ON/OFF signal line as follows:

- (a) The collector of Q6 should be 0 Vdc when the LPA is off and +13 Vdc when the LPA is commanded to turn on by the 100 Watt Transceiver.
- (b) If this is not the case, check the signal at U8 pin 4 and U5C pin 5 (should be high when the LPA is commanded on and low when the LPA is commanded off). Check also the Q6 base circuitry (R4, R13, R18, and CR28).
- (c) If this circuitry is okay, check for an open or a short on the line between Q6 and pin 27 of J3 (check for an open L7 or a shorted C4).

- (2) The LPA powers up when commanded to by the transceiver, but no LPA status is displayed on the transceiver's front panel. The LPA cannot be turned off or controlled from the transceiver.

This indicates a fault in the UART circuitry. Check it as follows:

- (a) Connect an oscilloscope to pin 4 of U4. You should see a data waveform (data pulses) when the LPA is commanded to turn on.
- (b) If not, check for a low on pin 1 of U4, which indicates that transistor Q7 is turned on or shorted. If Q7 is on, then U4 is probably bad. If Q7 is off, the problem is probably in the collector circuit of Q7, in Q7 itself, or in the components between the base of Q7 and U13, including U13 itself.
- (c) If pin 4 of U4 is good, check pin 20 of U13, which should be high with the LPA turned on and have low-going pulses when the LPA is given a command.

## NOTE

In order to generate a data waveform, you must turn the LPA off and on or command it to switch from STANDBY to OPERATE.

If no data waveform was seen at pin 20 of U13, the problem is probably U2E or U14A.

- (d) If pin 20 of U13 is good, check for the clock signal at pins 17 or 40 of U13. You should see a 78.6 KHz square wave.
- (e) If the clock signal is present, the problem has to be U13, U10, U11, U3A, or U5D.
- (f) If the clock signal is not present, the problem is in the UART clock oscillator/divider circuitry (U15, U16A,

U16B, U16F, and their associated components).

(3) The LPA powers up when commanded to by the 100 Watt Transceiver, the LPA status is displayed on the transceiver's front panel, but the LPA cannot be controlled (can't be commanded to go from STANDBY to OPERATE) from the transceiver.

(a) The problem is most likely in one of the following: U7B, U12, U2A, or U2C.

(b) To trace the data flow through these components, toggle the LPA between STANDBY and OPERATE.

(4) The coupler does not tune. This is indicated by one or more of the following symptoms:

o The BYPASS message appears on the transceiver's display.

o You cannot hear the coupler's tuning elements moving.

o The meter on the transceiver and/or the LPA indicates a high VSWR.

(a) Check for the TUNE PULSE signal at the collector of Q5. This signal should be a momentary low when the transceiver is keyed, but high otherwise. If this signal is not correct, check U8, U9B, Q5, and their associated components.

(b) If the TUNE PULSE signal is good, check the KEY DISABLE line. This includes L16, U17A, U5B, U17C, U2D, and their associated components. This signal should go low when the mike is keyed and then go high again after the coupler reaches its home position and sends the TUNE POWER REQUEST signal.

(c) If the KEY DISABLE signal is good, check the TUNE POWER REQUEST signal line (pin 4 of J3 to L14 to pin 4 of U6). This signal is low and is issued by the coupler when it reaches its home position. The TUNE POWER

REQUEST signal causes the KEY DISABLE signal to go high. The TUNE POWER REQUEST line goes high when the coupler becomes tuned.

(d) If all the above signals are good but the coupler does not tune, U6 or U9F is probably bad.

(5) Neither the coupler nor the LPA tunes when the system is keyed.

In this situation, the COND KEY line is the prime suspect. Check the circuitry between pin 4 of J2 and the collector of Q1. When the system is keyed, there should be a low at the cathode of CR4 and a high at the collector of Q1. When the system is not keyed, these points should be in the opposite logic states.

(6) When the system is keyed, the coupler tunes but the LPA doesn't.

Check the LPA KEY line: U5F and L3. This line should be low when the system is keyed and high when it isn't.

(7) When the system is keyed, the LPA tunes but the coupler doesn't.

Check the CPLR KEY line: U3E, R22, Q3, and L15. When the system is keyed, check for highs on pins 12 and 11 of U3E and lows on the base and collector of Q3. These signal levels should be reversed when the system is unkeyed.

6-19 MULTIVOLTAGE SUPPLY ASSY, A1A14.

a. Preliminary Procedure.

(1) Disconnect, but do not remove, the good Multivoltage Supply Assy in the test-bed 100 Watt Transceiver.

(2) In its place, connect the faulty Multivoltage Supply Assy.

(3) Power up the transceiver.

- (4) Check the output voltages of the Multivoltage Supply Assy at the test points on the Interconnect PWB Assy:

TP1 (brown)	ground
TP2 (red)	-15 Vdc
TP3 (orange)	+15 Vdc
TP4 (yellow)	+13.6 Vdc
TP5 (green)	+5 Vdc

- (5) The following are the most common cases of Multivoltage Supply Assy problems:

Case 1	All voltages are bad
Case 2	Only +5 V is bad
Case 3	Only +15 V is bad
Case 4	+5 V, +15 V are bad; -15 V is high
Case 5	Only -15 V is bad
Case 6	Voltages are too high
Case 7	Voltages are too low

- (6) The troubleshooting procedures for the Multivoltage Supply Assy are based on an analysis of each of these cases. Refer to section b below.

b. Troubleshooting Procedures.

CASE 1

All voltages are bad.

- (1) Check to see if fuse F1 (10 A slow blow) on the back of the transceiver is blown. If so, Q8 or Q9 on the Multivoltage Supply Assy could be shorted out. Proceed as follows:
- Unplug the Multivoltage Supply Assy from the transceiver.
  - Check the resistance of pin 4 of Multivoltage Supply Assy plug P1 to ground.
  - If the resistance measurement indicates a short, remove the cover of the Multivoltage Supply Assy.
  - Remove the nuts holding the collector leads of power transistors Q8 and Q9.
  - Check the transistors with an ohmmeter to see if they are shorted.

- (2) If fuse F1 is not blown, turn off the transceiver and remove the cover from the Multivoltage Supply Assy. Then remove the circuit board and the EMI filter from the chassis.

- (3) Power up the transceiver again, and check the collector of Q1. You should see approximately +13.0 Vdc from the 13.6 V Power Supply.

- (4) If the voltage at the collector of Q1 is good, check pin 15 of U1 for approximately +14.3 Vdc.

- (5) Check pins 12 and 13 of U1 for a 25 KHz square wave with an amplitude of 1.5 to 2 V pk-pk. The signals at pins 12 and 13 should be 180 out of phase. If this signal is good, skip to step 10.

**NOTE**

If the signal at pins 12 and 13 consists of narrow positive pulses, you have a possible current limit condition, which is indicated by +1.2 Vdc at the junction of R40, R44, and R39. If not, proceed to step 6. If there is a current limit condition, disconnect the wires to E2 and E3 and see if the voltage at these points returns to normal. If so, the problem is either in the EMI filter (check it with an ohmmeter) or in the current limit circuit (Q7 and its associated components). If disconnecting the E2 and E3 wires does not return the voltage to normal, check the resistance to ground from each point. If a short is indicated, trace it out. If not, the problem could be T3, Q8, Q9, or one of their associated components.

- (6) If the signal at pins a low (less than +0.5 Vdc) at pin 10. If pin 10 is high, check pin 7 of AR1. If pin 7 of AR1 is high, either the incoming voltage is high (greater than +33 Vdc) or there is a problem with the AR1 circuitry.

- (7) If the voltage at pin 10 of U1 is good (low), check for approximately +2.6 Vdc at pin 9. If pin 9 is low, check pin 1 of AR1. If pin 1 of AR1 is high, either the incoming voltage is low (less than +9 Vdc) or there is a problem with the AR1 circuitry. If pin 1 of AR1 is low,

there could be a problem with Q12, Q6, or one of their associated components.

- (8) Check the voltage on pins 1 and 2 of U1. If pin 2 (which should be +2.5 Vdc) is higher than or equal to pin 1, then the voltage at pin 9 should be okay, unless there is a problem with U1 or the pin 9 line is shorted.
- (9) If pin 2 does not read +2.5 Vdc, check for +5 Vdc at pin 16. If pin 16 does not read +5 Vdc, either U1 is bad or there is a bad component shorting the pin 16 line.
- (10) Check the collectors of Q3 and Q4 for a 25 KHz square wave (not as clean as at pins 12 and 13 of U1) at an amplitude of at least 13 V pk-pk. If the signal is bad here, check for a fault in Q3, Q4, or one of their associated components.
- (11) Check the collectors of Q8 and Q9 for the composite wave shown below (figure 6-20): The pk-pk amplitude should be twice the input voltage to the Multivoltage Supply Assy (or approximately 26 V). If this signal is good, skip to step 15.
- (12) If the above signal is not present, check to see whether the line voltage (+13.0 Vdc from the 13.6 V Power Supply) is on the collectors of Q8 and Q9. If it isn't, skip to step 14. If it is, check the bases for a signal similar to the one in figure 6-21.
- (13) If the above signal is present, Q8 or Q9 is probably bad. If it is not present, the problem is in T1 or its associated circuitry.
- (14) If line voltage is not present at the collectors of Q8 and Q9, check for a problem with T3 or its associated wiring.
- (15) Look at pin 1 of U2 for +15 Vdc. If this voltage is not present, there could be a problem in the secondary circuitry of T3 or in T3 itself.
- (16) If the voltage at pin 1 of U2 is good, check E2, E3, and E6 for the proper output voltages. If good, the problem has to be in the wiring, the connector, or the EMI filter.

#### CASE 2

Only the +5 V is bad.

The problem is in the +5 V regulator circuit (U2 and its associated components). Check it as follows:

- (1) Check for +15 Vdc at pin 1 of U2.
- (2) Check for a 3.5 V pk-pk square wave at pin 7. If the signal is good, skip to step 4.

#### NOTE

If the signal at pin 7 of U2 consists of narrow pulses, you have a possible current limit condition, which is indicated by +0.5 Vdc at pin 6 of U2. If this is the case, disconnect the wire from E6. If the output voltage returns to normal, the EMI filter is probably bad. If the voltage does not return to normal, check for a short in Q10, Q11, T4, CR13, CR21, etc. If pin 6 of U2 does not indicate a current limit condition, check the zener voltage at pin 2 of U2 for +8.2 Vdc. Check to see that pin 3 is less than pin 2. If not, there is a problem either with U2 or its associated circuitry.

- (3) Check for +4 to 4.5 Vdc at pin 4 and +3.7 Vdc (approximately) at pin 3. If these voltages are incorrect, troubleshoot the circuitry supplying them.
- (4) Check the collector of Q13 for a pk-pk signal that is approximately 1.5 V. If it's not there, Q13 or its associated circuitry is bad.
- (5) Check the collector of Q10 for a pk-pk signal equal to the supply voltage. If it's not there, check for a problem in Q10, Q11, or their associated components.
- (6) Check E6 for +5 Vdc. If the voltage here is good, the EMI filter is probably bad. There could also be a problem in the wiring or the connector.

#### CASE 3

Only the +15 V is bad.

Check for a problem in the EMI filter or the wiring.



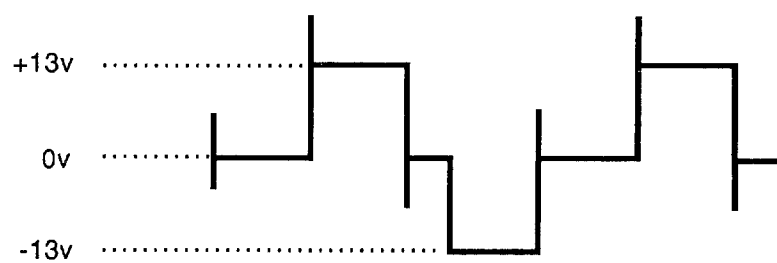

Figure 6-20. Composite Wave

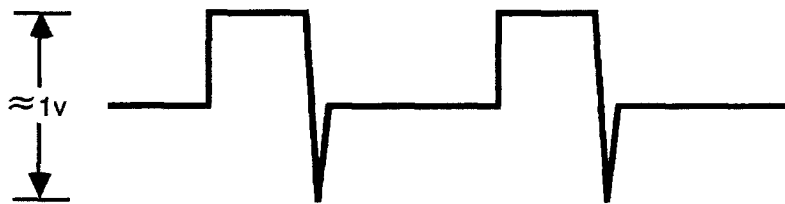

Figure 6-21. Base Signal for Q8, Q9

Check for a problem in the EMI filter or the wiring.

#### CASE 4

+5 V, +15 V are bad; -15 V is high.

Check for a problem with CR12, L2, the EMI filter, or the wiring.

#### CASE 5

Only the -15 V is bad.

Check for a problem with CR16, CR1, L3, the EMI filter, or the wiring.

#### CASE 6

The voltages are too high.

- (1) Check the reference voltage at pin 2 of U1, which should be +2.5 Vdc.
- (2) If the voltage at pin 2 is incorrect, check for +5 Vdc at pin 16. If the voltage at pin 16 is good, check for a problem in reference divider R15 and R16.
- (3) If the voltage at pin 2 is correct, check the voltage at pin 1, which should also be +2.5 Vdc. If not, check voltage divider R4, R5, R6, R57. If the voltage at pin 1 is lower than it should be, this will cause the output voltages of the Multivoltage Supply Assy to be high.

#### CASE 7

The output voltages are too low.

Check for a current limit condition by measuring the voltage at the junction of R39, R40, and R44. If the voltage is +1.2 Vdc, the current limit condition is in effect. Troubleshoot this condition the same way as in the note after step 5 of Case 1.

### 6-20. INTERCONNECT PWB ASSY, A1A15.

In all probability, the Interconnect PWB Assy by itself will never be sent back for repair. This is because the Interconnect PWB Assy is not identified in any of the on-equipment troubleshooting procedures as the cause of an equipment malfunction. The Interconnect PWB Assy contains very few electronic components: two LEDs (one indicating the presence of +5 Vdc, the other indicating the presence of +13.6

Vdc) and a filter for the Multivoltage Supply Assy, which consists of an inductor and a capacitor. However, since the Interconnect PWB Assy is a junction point for all the other boards in the 100 Watt Transceiver, it contains, in addition to its many printed-circuit traces, 13 cables (P1-P13) and 9 jacks (J1-J9). An open wire in a ribbon cable or a faulty connector contact might generate a fault code during an automatic BIT routine which points to another board, when in reality the problem is on the Interconnect PWB Assy. Therefore, when replacing the board indicated by the BIT procedure fails to correct the equipment fault, the entire transceiver may be sent back to the depot for repair. In this case, the Interconnect PWB Assy may be considered a prime suspect.

Troubleshooting the Interconnect PWB Assy is limited to the following actions:

- o Checking the power supply voltages at test points TP1-TP5
- o Checking the output of the capacitor and inductor to the Multivoltage Supply Assy
- o Standard signal-tracing techniques and continuity checks for the board's lands, cables, and connectors

#### CAUTION

When checking connectors, do not insert meter probes larger than 0.025 inch in diameter. The use of larger probes may cause damage to the contacts, resulting in intermittent equipment problems.

### 6-21. AUDIO INTERFACE PWB ASSY, A1A16.

- a. Preliminary Procedure. Remove the good Audio Interface PWB Assy from the test-bed 100 Watt Transceiver, and in its place connect the faulty Audio Interface PWB Assy. It is not necessary to mount the board to the transceiver chassis.
- b. Checkout and Troubleshooting Procedures.

- (1) Check the PATCH circuitry as follows:

4-WIRE, 2-WIRE PATCH IN

- (a) Connect an audio signal generator to the PATCH IN (4W) terminals (1 and 2) on TB1 at the rear of the transceiver.
- (b) Set the signal generator for a 1 KHz tone at -20 dBm.
- (c) On the transceiver front panel, select the AUDIO meter and the PATCH audio source.
- (d) Set the PATCH selector switch (S1) on the Audio Interface PWB Assy to the "4" position.
- (e) If the PATCH IN circuitry is working properly, you should be able to adjust the PATCH XMIT potentiometer on the transceiver front panel for 0 dBm on the meter.
- (f) Set the PATCH selector switch (S1) on the Audio Interface PWB Assy to the "2" position.
- (g) Repeat step e with the signal generator connected to the "2W" PATCH terminals on TB1.

4-WIRE, 2-WIRE PATCH OUT

- (h) Connect an RF signal generator to the antenna jack (J1) at the rear of the transceiver.
- (i) Set the signal generator for a carrier frequency of 15 MHz at approximately -20 dBm. Select a modulating frequency of 1 KHz at 50% modulation.
- (j) Select PATCH on the transceiver's front panel meter, and select PATCH as the audio source. Select AME mode at 15 MHz.
- (k) If the PATCH circuitry is working properly, you should be able to adjust the PATCH RCV potentiometer on the transceiver front panel for 0 dBm.

- (l) Connect an oscilloscope to the PATCH OUT terminals (3 and 4) on TB1 at the rear of the transceiver.
- (m) Set the PATCH selector switch (S1) on the Audio Interface PWB Assy to the "4" position.
- (n) Note that the signal on the oscilloscope varies as you adjust the PATCH RCV potentiometer. The signal should be approximately 2 V pk-pk when the meter reading is 0 dBm.
- (o) Set the PATCH selector switch (S1) on the Audio Interface PWB Assy to the "2" position.
- (p) Connect the oscilloscope to the "2W" PATCH terminals on TB1 (2 and 3). The signal should be about the same level as in step n.

- (2) Check the LINE circuitry as follows:

4-WIRE, 2-WIRE LINE OUT

- (a) Connect an RF signal generator to the antenna jack (J1) at the rear of the transceiver.
- (b) Set the signal generator for a carrier frequency of 15 MHz at approximately -20 dBm. Select a modulating frequency of 1 KHz at 50% modulation.
- (c) Set the transceiver to 15 MHz AME.
- (d) Connect an oscilloscope to the LINE OUT terminals on TB1 (7 and 8) at the rear of the transceiver.
- (e) Select LINE on the transceiver's meter, with any audio source.
- (f) Set the LINE selector switch (S2) on the Audio Interface PWB Assy to the "4" position.
- (g) Adjust the LINE potentiometer on the transceiver's front panel for +10 dBm. Note that the audio signal on the oscilloscope varies in size as you adjust the potentiometer. The signal on the

oscilloscope should be approximately 7 V pk-pk when the meter indicates +10 dBm.

- (h) Connect the oscilloscope to pins 13 and 12 of the REMOTE connector J9 at the rear of the transceiver. You should get the same signal as before. This checks the continuity of the J2 connector output on the Audio Interface PWB Assy.
- (i) Connect the oscilloscope to the "2W" LINE terminals on TB1 (6 and 7) at the rear of the transceiver, and select the "2" position for switch S2 on the Audio Interface PWB Assy. The signal on the oscilloscope should be the same as in step g.

#### 4-WIRE, 2-WIRE LINE IN

- (j) Connect an audio signal generator to the LINE IN terminals on TB1 at the rear of the transceiver.
- (k) Set the signal generator for a 1 KHz signal at -10 dBm.
- (l) Select 10 MHz USB on the transceiver.
- (m) Select LINE on the transceiver's meter.
- (n) Set the LINE selector switch (S2) on the Audio Interface PWB Assy to the "4" position.
- (o) Key the transceiver, and check that the signal strength of the signal generator (-10 dBm) matches the indication on the meter.
- (p) Increase the output level of the signal generator to 0 dBm. Note a corresponding increase in the signal strength indicated on the meter.

#### NOTE

Steps q-t check the continuity of the J2 connector output on the Audio Interface PWB Assy.

- (q) Connect the signal generator output to pins 24 and 25 of the REMOTE connector J9 at the rear of the transceiver.
  - (r) Repeat steps o and p. The results should be the same.
  - (s) Connect the signal generator to pins 13 and 24 of the REMOTE connector J9. Set the LINE selector switch (S2) on the Audio Interface PWB Assy to the "2" position.
  - (t) Repeat steps o and p. The results should be the same.
  - (u) Connect the signal generator to the "2W" LINE terminals (6 and 7) on TB1 at the rear of the transceiver.
  - (v) Repeat steps o and p. The results should be the same.
- (3) If any of the above checks indicate a problem in the Audio Interface PWB Assy circuitry, use standard signal-tracing techniques to isolate the faulty component, whether it be the hybrid transformers, series resistors or capacitors, or the board itself.

**6-22. COUPLER CONNECTOR PWB ASSY, A1A17.** This board and its attached ribbon cable provide the connections between the LPA/Coupler Interface PWB Assy and the J5/J8 connectors on the back of the 100 Watt Transceiver. Therefore, this board is a possible suspect whenever there is a high VSWR (fault code 1A1A5-8) or whenever the LPA/Coupler Interface PWB Assy is suspected of being at fault (fault code 1A1A1-1) or whenever there is a break in the communications between the transceiver and the power amplifier and/or antenna coupler.

Troubleshooting this board and its attached cable consists of continuity checks from input to output. There are no electronic components on the board.

**CAUTION**

When checking connectors, do not insert meter probes larger than 0.025 inch in diameter. The use of larger probes may cause damage to the connector contacts, resulting in intermittent equipment problems.

**6-23. AFSK MODULE ASSY, A1A18.**

a. Preliminary Procedure.

- (1) Remove the good AFSK Module Assy from the test-bed 100 Watt Transceiver, and replace it with the faulty AFSK Module Assy.
- (2) Power up the transceiver.
- (3) Check for the presence of the following power supply voltages on the board:

Voltage:	Measure at:
+5 Vdc	+ side of C4
+15 Vdc	+ side of C2
-15 Vdc	- side of C6
+2.28 Vdc	Junction of R1, R2
+5 VR	R53 (side away from L3)
-5 Vdc	Anode of CR1
+12 Vdc	+ side of C88
-12 Vdc	- side of C71

- (5) If the voltages check good, run the receive-only BIT test.

b. Interpreting the BIT Fault Codes. Use the fault codes listed below as a guide in troubleshooting the AFSK Module Assy. Refer to the section corresponding to the fault code you get. In the event that the BIT test runs without generating a fault code, start at the beginning of the following procedures and work your way through to the end.

BIT Test Description for the  
AFSK Module Assy

1. Checks for the presence of the module by sending data to it and checking to see whether the MCB loopback bit was sent back in reply.

2. If the module is present (the MCB loopback bit is received by the microprocessor), keys the module and places it in a loopback configuration.
3. Verifies that a mark and a space applied to the keyer are detected as a mark and a space by the converter.

1A1A18-1

This fault code indicates that no AFSK audio was detected by the microprocessor at the output of TTL Converter U6 on the AFSK Keyer/Converter PWB Assy. The problem could be either in the Converter section of the board or the Keyer section. The following procedure first checks the Converter, then checks the Keyer.

CONVERTER SECTION

- (1) Select AFSK on the front panel of the transceiver. If the AFSK indicator appears on the display, then the MCB loopback circuitry (U14, U15, U16, U19, and their associated components) is probably good.
- (2) Check TP3 with an oscilloscope for the 1.25 MHz clock signal (0-5 V pk-pk square wave).
  - (a) If the clock signal is incorrect or missing, check pin 15 of U3 for a low (this is the CLOCK ENABLE line).
  - (b) If pin 15 of U3 is not low, check for a high on either pin 1 or pin 2 of U7C. Refer to the chart on the schematic for the high-low combination required for the shift selected by S1 on the AFSK Filter PWB Assy. If neither pin is low, trace the shift select lines back to shift register U16.
  - (c) If pin 15 of U3 is low, the problem is in the clock oscillator circuit. Check for +5 Vdc on pin 1 of U12A.
  - (d) If TP3 is good, proceed to step 3.
- (3) Inject a 100 mV rms signal at pin 19 of J2. Set the frequency according to the shift

that is selected by S1 on the AFSK Filter PWB Assy:

<u>Shift:</u>	<u>Signal Generator Frequency</u>
850 Hz	000 Hz
170 Hz	1000 Hz
85 Hz	500 Hz

- (4) Check TP1 with an oscilloscope. You should see 0-5 V spikes at twice the input frequency.
  - (a) If TP1 is bad, check for a square wave at the input frequency at pin 7 of U2.
  - (b) If TP1 is good, proceed to step 5.
- (5) Check the signal at TP2. You should see a square wave 12 V above and below ground at twice the input frequency.
  - (a) If TP2 has no signal, check pin 10 of U5 for a 0-5 V square wave at the same frequency as TP1. If the signal is bad here but good at pin 11 of U5, then either U5 is bad or the required information never got loaded from registers U17 and U18.
  - (b) Check for a low at pin 21 of U5D (this is the chip select line). If pin 21 is not low, U18 could be bad. If pin 21 is low, try replacing U5 (it's socketed).
- (6) If TP2 is good, check pin 7 of U6 with an oscilloscope or a DC voltmeter. You should read +5 Vdc (a mark). If not, work your way back through AR8 and AR2.
- (7) If U6 pin 7 is good, check pin 15 of U9 for -4 to -6 Vdc (a mark).
  - (a) If this voltage is good, select AFSK CREV on the front panel. The voltage should now be +4 to +6 Vdc. If not, check pin 9 of U4 for the CREV signal (should be a low).
  - (b) Check also U7 pin 5. You should see a low for the normal (not hold) condition.
  - (c) Check also pin 4 of U7 for a low, indicating that the signal is present. If

this pin is high, you're in a mark-hold condition. Trace the signal line back through U21B and AR7.

- (8) You can also try shifting the signal generator frequency to see whether a voltage shift occurs at pin 15 of U9, pin 2 of U9, pin 6 of U7, pin 7 of U6, etc.
- (9) Look also at the junction of R87 and R88. You should see +2.5 Vdc when you're at the center frequency. If the frequency goes up, the voltage here should go up.

#### KEYER SECTION

- (1) Inject +6 Vdc at pins 8 and 9 of J3.
- (2) Key the transceiver with the 2ND, TX KEY buttons on the front panel.
- (3) Check pin 3 of U13 for a 0-2.5 V square wave at the selected center frequency plus the space offset. For example, if your center frequency is 2000 Hz and your shift is 850 Hz, then you should see a 2425 Hz signal at pin 3 of U13.
- (4) If the signal is not there, check pin 10 of U11 for a low with the transceiver keyed. This is the CONDITIONED KEYLINE. If this pin is low, check pin 13 of U5B for a square wave at twice the space frequency (in our example, 4850 Hz). Pin 17 of U5B should remain high.
- (5) If the signal at pin 3 of U13 is good, check pin 4 of U1 for an audio frequency sine wave (in our example, 2425 Hz) at 100 mV rms. If this signal is bad, check the signals at U13, specifically the coding at the AFSK FILTER SELECT lines, pins 10 and 11. Refer to the chart on page 5 of the schematic for the coding.
- (6) If the signal at U1 pin 4 is bad, you might try selecting a different frequency shift with S1 on the AFSK Filter PWB Assy. This will determine whether the problem is in one of the shift filters (AR4, AR5, and their associated components).

1A1A18-2

This fault code indicates that the 455 KHz AFSK IF signal was not detected at the output of the IF Filter PWB Assy. The problem is probably in the AFSK Filter PWB Assy or in the filter select circuitry on the AFSK Keyer/Converter PWB Assy.

The first thing to do is determine whether the problem occurs at only one frequency shift or at all of them. Do this by running the BIT test again after changing the position of S1 on the AFSK Filter PWB Assy and then resetting the microprocessor (see the note after step 2 below). This will help you decide whether to perform the following steps for only one filter circuit or for all of them.

- (1) Inject a 455 KHz, -32 dBm signal at J1 on the IF Filter PWB Assy.
- (2) Select each filter on the AFSK Filter PWB Assy with switch S1.

**NOTE**

After you select a filter with S1, you must reset the microprocessor to make sure that the microprocessor reads the new selection. You can reset the microprocessor by pushing the reset button on the Transceiver Control PWB Assy with power on or by switching the transceiver off and then on again.

- (3) Check for the signal at the output of the IF Filter PWB Assy (J2). There should be about 17 +/-2 dB of signal gain.
- (4) Check for -15 Vdc at the input resistor (R1, R6, or R11) on the selected filter line. The unselected lines should have +15 Vdc at their input resistors.
- (5) If the voltages are incorrect, disconnect the AFSK Filter PWB Assy from the AFSK Keyer/Converter PWB Assy and check it for shorts. Check also switch S1.
- (6) The problem could also be in the filter select circuitry on the Keyer/Converter PWB Assy, specifically AR5, AR6, U20A, and their associated components.

**6-24. REMOTE CONTROL INTERFACE PWB ASSY, A1A19**

a. Preliminary Procedure.

- (1) Remove the good Remote Control Interface PWB Assy from the test-bed 100 Watt Transceiver, and replace it with the faulty Remote Control Interface PWB Assy.
- (2) Make sure that the transceiver is connected to a Remote Control Unit and that the connecting cable has all 25 wires.
- (3) Power up the transceiver.
- (4) Switch on the Remote Control Unit.
- (5) Check for the presence of the following power supply voltages on the Remote Control Interface PWB Assy:

<u>Voltage:</u>	<u>Measure at:</u>
+5 Vdc	+ side of C1
+15 Vdc	anode of CR1
-15 Vdc	- side of C18
-5 Vdc	- side of C19
+12 Vdc	U9, pin 14

- (6) If the voltages check good, run the receive-only BIT test.

- b. Interpreting the BIT Fault Codes. Use the fault codes listed below as a guide in troubleshooting the Remote Control Interface PWB Assy. Refer to the section corresponding to the fault code you get. In the event that the BIT test runs without generating a fault code, try to select remote operation from the transceiver front panel and follow the procedures listed under "RCU OFF, LCU OFF" at the end of this section.

BIT Test Description for the Remote Control Interface PWB Assy

1. Checks for the presence of the board by detecting the R IDENT signal (which is simply a ground supplied to the Transceiver Control PWB Assy on pin 34 of the connecting cable when the board is installed). This check is actually performed on power up.



2. Reads the code on the Baud Rate Select Switch S1 on the Remote Control Interface PWB Assy.
3. Places the UART U7 in a loopback configuration and verifies that data sent to the UART is sent back.

## 1A1A19-1

This fault code indicates that the microprocessor did not read the code set up by switch S1 (Baud Rate Select) or that the code read was an invalid one.

In order for this part of the BIT test to pass, several components have to function correctly: U2, U5, U8, U15C, U15D, U3, R4, and S1. The object of the following procedure is to determine which of these components is defective.

- (1) Check the code-generating components (S1, R4) as follows:
  - (a) Set S1 to position 0 (300 baud).
  - (b) You should see lows on pins 15-18 of U3.
  - (c) Set S1 to position 5 (9600 baud).
  - (d) You should see lows on pins 15 and 17 of U3 and highs on pins 16 and 18.
  - (e) If all these voltages are correct, then switch S1 and R4 are good.
- (2) Run the BIT receive-only test at two different baud rates: first 300 and then 9600. Make sure that the baud rate switch on the Audio/Microprocessor PWB Assy in the Remote Control Unit is set to the same position as the baud rate switch (S1) on the Remote Control Interface PWB Assy. Also, you must press the microprocessor reset switch on the Transceiver Control PWB Assy after you change the position of the baud rate select switch. Otherwise, the microprocessor will not be aware that the baud rate was changed.
- (3) If the BIT test passes at one baud rate but not the other, then U3 is probably bad. If you get the 1A1A19-1 fault code at both

baud rates, try to select remote operation from the transceiver.

- (4) If the transceiver successfully selects remote operation, then U3 is almost certainly bad. If the transceiver fails to select remote operation (the message "RCU OFF" is displayed on the transceiver and the message "LCU OFF" is displayed on the Remote Control Unit), U3 is probably good.
- (5) Check U8 by seeing whether the signals on the B side are transferred to the corresponding pins on the A side. If so, U8 is good. If not, replace U8.
- (6) Check U15C and U15D by verifying that the logic levels are what they should be at the inputs and outputs of the gates.
- (7) If all the above checks are good, the problem is either U5 or U2.

## 1A1A19-2

This fault code indicates that the microprocessor sent data to UART U7 but did not receive data in return.

Since fault code 1A1A19-1 was not declared, all the circuitry up to U7 is probably good. The problem is almost certainly U7 or the clock oscillator circuit. Check for the clock signal at pin 20 of U7. If it's there, replace U7. If it's not, troubleshoot the clock oscillator circuit.

## rcu OFF, LCU OFF

If the transceiver cannot establish a communications link with the Remote Control Unit after remote operation has been selected, "rcu OFF" will appear on the transceiver's display, and "LCU OFF" will appear on the Remote Control Unit's display. If the BIT test does not indicate any failures, the problem is most likely in the interface circuitry. Check it as follows:

- (1) Try establishing a communications link on each of the other interfaces. Remember that the interface select switches in both the transceiver and the Remote Control

Unit must be set the same. Also, when selecting modem, make sure that you change the baud rate to 300 on both units and that the 2-wire, 4-wire select switches are set the same.

- (2) If the failure occurs in only one specific interface, then troubleshoot the circuitry unique to that interface:

<u>Failure in:</u>	<u>Check:</u>
RS-232 only	U14A, U13A, C29
RS-422 only	U10, U11
MS-188 only	U4C, U14B, U13B, U4E, C30
Modem only	U1, U9, VR4, U18, S5, T1, T2, and their associated components

In the case of modem, the signal you are tracing is audio tones; in all other cases, the signal consists of a series of pulses. The Remote Control Unit sends a series of pulses to the Remote Control Interface PWB Assy every 5 seconds in an attempt to receive a response. If the Remote Control Interface PWB Assy does not transmit any pulses in response, the Remote Control Unit will keep polling.

- (3) If the RS-232 interface works but none of the others does, then check U11A and its associated components.
- (4) If none of the interfaces works, then do the following:
- (a) Check Interface Select Switch S2. There should be receive pulses from the Remote Control Unit every 5 seconds on pins 0-3 (each pin corresponds to a different interface). Check to see that these pulses also appear on the common pin. If not, replace the switch.
- (b) Check U10. Also check the 422 EN line coming into it at pin 3. This line must be low for the interfaces to work. If this line is not low, the problem could be in U1 or one of its associated components.

- (c) If the above components check good, the problem may not be in the interface circuits. Proceed to step 5.

- (5) Check the signals in and out of UART chip U7 as follows:

- (a) With an oscilloscope, check for a series of pulses every 5 seconds on pin 3. These are the poll commands from the Remote Control Unit.

- (b) Connect the other channel of the oscilloscope to pin 14. When there is activity on pin 3, there should be a series of narrow, negative-going pulses on pin 14. The negative transition indicates that a pulse went out to the microprocessor; the positive transition indicates that the microprocessor read it. If there are no pulses on pin 14 with pulses on pin 3, then replace U7.

- (c) If these signals are good, check for a series of transmit pulses on pin 19. If the pulses are not there, check pin 15 for a series of pulses. If no pulses are there either, replace U7.

**6-25. POWER SUPPLY PROTECTION AND CONTROL PWB ASSY, A2A1.**

a. Preliminary Procedure.

- (1) Remove the good Power Supply Protection and Control PWB Assy from the test-bed 100 Watt Transceiver, and replace it with the faulty Power Supply Protection and Control PWB Assy.
- (2) Power up the transceiver.
- (3) Listen for the clicking of the relays: the ON/OFF Relay (AC or DC, depending on the type of input power you have) and the Step-Start Relay.
- (4) Check the operation of the fan. The fan should come on at low speed and switch to high speed only when the temperature inside the transceiver rises above 65 C.
- (5) Based on the what the relays and the fan do when you apply power, troubleshoot

the Power Supply Protection and Control PWB Assy according to the symptoms in section b below.

b. Troubleshooting Procedures.

CASE 1

No relays are heard.

- (1) Check to see whether LED DS1 (AC operation) or LED DS2 (DC operation) is on. If it is, check for a problem in J1 (DC) or J2 (AC). If it is not on, proceed to step 2.
- (2) Check for approximately 3 Vdc at L1.
- (3) If the voltage at J4 pin 5 is correct, check for a low at pin 1 of AR1. If AR1 pin 1 is not low, there is a problem with either AR1 or one of its surrounding components. Check voltage divider R42, R43, R44 and also the +7.5 V regulator.
- (4) If the output of AR1 pin 1 is low, do the following:

DC Operation

- (a) Check for a low at the collector of Q1. If Q1's collector is low, check for the presence of the DC input voltage (should be approximately +12 Vdc) at the cathode of CR1. If the voltage is incorrect, trace the circuit back to the input at J1 pin 5. If Q1's collector is not low, proceed to step b.
- (b) Check for a low at the collector of Q3. If Q3's collector is low, check the position of the jumper at TB1. Make sure the jumper is set correctly for the input voltage.
- (c) If the jumper position is correct, look for a problem in the Overvoltage Protection Circuit (Q2, Q3, and their associated components).
- (d) If Q1's collector is not low and Q3's collector is not low, the problem is probably in Q11, Q12, Q1, or one of their associated components.

AC Operation

- (a) Check for a low at the collector of Q15. If Q15's collector is low, check the positive side of C6 for approximately +12 Vdc. If the voltage is incorrect, check CR26, CR27, and C6 for a possible fault. If Q15's collector is not low, proceed to step b.
- (b) Check the voltages around Q14 and the base of Q15. Q14 should be biased to conduct. If Q14 is not conducting, check for a problem in Q14 itself or one of its associated components. If it is conducting, then Q15 is probably bad.

CASE 2

Only one relay is heard.

In this case, the problem is probably in the Step-Start Relay circuitry. Check it as follows:

- (1) Check for a low at the collector of Q4. If Q4's collector is low, check for the positive supply voltage (approximately +28 Vdc) at the anode of CR14. If this voltage is incorrect, check CR14, C4, Q7, and their associated components. If Q4's collector is not low, proceed to step 2.
- (2) Check the collector of Q3. If it is low (less than 1.0 Vdc), this indicates an overvoltage condition. Check the incoming line voltage. If Q3's collector is not low, proceed to step 3.
- (3) Check the collector of Q5 for +8 to +18 Vdc. If this voltage is correct, the problem is probably Q4 or one of its associated components. If the voltage at Q5's collector is incorrect, proceed to step 4.
- (4) Check for +8 to +17 Vdc at the collector of Q7. If this voltage is good, the problem is probably in Q5 or one of its associated components. If the collector of Q7 is at line voltage (+28 Vdc), then look for a problem in Q7 or one of its associated components.

CASE 3

Both relays are heard, but the fan does not run.

Look for a problem in connector J1 (pins 2 and 3) or R38. Check for +12 Vdc at the emitter of Q9. If the voltage is not present, check CR16 and R28.

CASE 4

Both relays are heard, but the fan runs only at low speed.

To confirm that the fan runs only at low speed, ground the control line at J4 pin 5. If the fan will not run at high speed with J4-5 grounded, do the following:

- (1) Check the collector of Q8. If it is low, the problem is in Q9, Q10, or one of their associated components.
- (2) If the collector of Q8 is high, the problem is AR1 or one of its associated components.

CASE 5

Both relays are heard, but the fan runs only at high speed.

Check the collector of Q8. If it's low, the problem is probably in Q8, AR1, or one of AR1's associated components. If Q8's collector is high, look for a problem in Q9, Q10, or one of their associated components.

CASE 6

The relays and fan operate correctly, but the transceiver does not power up.

Check for a shorted shutdown transistor Q6. The collector of Q6 shouldn't be low unless the Step-Start Relay fails to energize.

6-26. 13.6 V POWER SUPPLY, A2A2.

a. Troubleshooting Procedure.

CASE 1

No output voltage.

- (1) Remove the good 13.6 V Power Supply from the test-bed 100 Watt Transceiver, and replace it with the faulty 13.6 V Power Supply. Remove the cover from the power supply.
- (2) Power up the transceiver.

- (3) Check to see if the input voltage (+28 Vdc nominal) is present at the collector of Q1. If not, troubleshoot the +28 Vdc input line.
- (4) If Q1's collector is good, check pin 15 of U1. The voltage here should be about 2 volts less than the input voltage. If this voltage is incorrect, the problem is probably in U1 and its associated circuitry.
- (5) If pin 15 of U1 is good, check the signal at pins 11 and 14 with an oscilloscope. You should see a 4 V pk-pk square wave with a 75% duty cycle. If this signal is good, skip to step 8.

NOTE

If you have narrow pulses at pins 11 and 14, check for the current limit condition, which is indicated by +1.2 Vdc at the emitter of Q10. If you are in current limit, disconnect the output to the EMI filter and see whether the output voltage returns to normal. If it doesn't, there is probably a short somewhere in the power supply.

- (6) If the signal at pins 11 and 14 is bad, check the voltage at pin 10. If pin 10 is high, this indicates the shutdown condition, which could be caused by any of the following:
  - o Incorrect line voltage
  - o A failure in the Undervoltage/Overvoltage Protection circuits
  - o Shutdown switch Q5, which can be triggered by the Undervoltage/Overvoltage Protection, Overtemperature, or Soft Start circuits.
- (7) If the voltage at pin 10 is low, check the other voltages on U1 as follows:
  - (a) Check for +3 to 3.5 Vdc at pin 9, which is the normal voltage if the power supply is not putting out.
  - (b) If pin 9 is not correct, check pin 2 for +2.5 Vdc.
  - (c) If pin 2 is not correct, check pin 16 for +5 Vdc.

- (d) If the voltage at pin 16 is bad, either U1 or its associated circuitry is bad.
- (8) If the signal at pins 11 and 14 of U1 is good, check the collector of Q7 for a signal whose pk-pk amplitude is 3 volts less than the incoming supply voltage. Trace this signal through Q9, Q1, Q2, and Q3.

#### CASE 2

High output voltage.

- (1) Try adjusting the voltage with potentiometer R26. See the alignments section.
- (2) If you can't adjust the voltage to +13.6 Vdc with the potentiometer, do the following:
- (a) Check Q1, Q2, and Q3 for collector-to-emitter shorts.
- (b) Check for a short in Q7 and/or Q9.
- (c) Check the voltage divider/reference network at pins 2 and 16 of U1, which consists of R13 and R14. Pin 2 should read +2.5 Vdc, and pin 16 should read +5 Vdc. Also, check the voltage on pin 1, which should be about the same as on pin 2.

#### NOTE

If pin 1 (which has the feedback voltage) is lower than pin 2, the power supply will try to put out more voltage.

#### CASE 3

Low output voltage.

- (1) Try adjusting the voltage with potentiometer R26. See the alignments section.
- (2) If you can't adjust the voltage to +13.6 Vdc, check the voltage divider/reference network at pins 2 and 16 of U1, which consists of R13 and R14. Pin 2 should read +2.5 Vdc, and pin 16 should read +5 Vdc. Also, check the voltage on pin 1, which should be about the same as on pin 2.

#### NOTE

If pin 1 is higher than pin 2, the power supply will try to cut back--no signal will appear at pins 11 and 14.

APPENDIX A

CHECKS PERFORMED DURING AUTOMATIC BIT ROUTINES FOR THE TRANSCEIVER

1. Turns on all front panel indicators for the duration of the test for inspection by the operator.
  2. Checks for major modules present by testing the ability to send data to and receive data from modules.
  3. Remote Control Interface PWB Assy (A1A19) - If installed, checks UART loopback and baud rate switch.
  4. Multivoltage Supply Assy (A1A14) - Checks +15V and -15V output voltages and compares them with stored limits.
  5. Disables speaker and mutes 600-ohm line.
  6. Reference/BFO PWB Assy (A1A9) - Verifies the presence of all outputs and verifies frequency lock of BFO at both ends of the frequency range.
  7. Synthesizer PWB Assy (A1A10) - Verifies the presence of output and frequency lock at both ends of the tuning range.
  8. Low Pass Filter PWB Assy (A1A5) - Activates BIT Oscillator and checks receive RF output with all filters deselected, then checks output with each filter selected in turn. If all filters pass, rechecks with all filters deselected, then selects Band 6, and sets the synthesizer to receive the BIT Oscillator.
  9. First Converter PWB Assy (A1A3) - Activates BIT Oscillator signal and verifies the presence of Rx (receive) IF output.
  10. Receiver PWB Assy (A1A7) - Activates BIT Oscillator and verifies the presence of IF to filters.
  11. IF Filter PWB Assy (A1A2) - Activates BIT Oscillator, then selects each filter, using the Synthesizer to center the BIT signal in each passband, and verifies the presence of 455 KHz IF output. If an AFSK option is installed, these filters are checked in a similar manner.
  12. Receiver PWB Assy (A1A7) - Bypasses volume and squelch controls, sets RF gain at maximum, and verifies that there is no line audio in USB. Activates BIT Oscillator and verifies the presence of a line audio level.
  13. AGC/TGC PWB Assy (A1A6) - Checks signal strength in USB at maximum RF gain with and without the BIT Oscillator activated. Checks signal strength with the BIT Oscillator activated at minimum RF gain.
  14. AFSK - Checks for presence of module; if present, keys module, places it in a loopback configuration, and verifies that a mark and space applied to the keyer are detected as a mark and space by the converter. If receive-only testing has been initiated, the test stops and the current operating status is restored. If receive/transmit testing has been initiated, the following additional steps occur.
- NOTE**
- The transceiver must be connected to a load with a VSWR of 2.0 to 1 maximum in order for this portion of the routine to proceed to completion.
15. Exciter PWB Assy (A1A1) - Applies a 1 KHz test signal to the MIC input, selects USB mode, and keys the transmitter; verifies the presence of 455 KHz IF output from Exciter.
  16. Receiver PWB Assy (A1A7) - Verifies the presence of IF to filters.
  17. Exciter PWB Assy (A1A1) -
    - (a) Verifies the presence of Exciter IF output;
    - (b) disables the 1 KHz test signal, selects AME, and verifies the presence of Exciter IF output; and (c) selects CW mode and verifies the presence of Exciter IF output.
  18. First Converter PWB Assy (A1A3) - Keys the radio in CW and verifies the presence of Tx (transmit) RF output.

- 19. 100 Watt PA (A1A4) - Keys the transmitter in CW and verifies the presence of Tx RF output.
- 20. Low Pass Filter PWB Assy (A1A5) - Keys the transmitter in CW and verifies the presence of the signal at RF IN/OUT.
- 21. AGC/TGC PWB Assy (A1A6) - Keys the transmitter in CW. Verifies the correct transceiver output power level and verifies that the TGC system has stabilized at a normal control level.
- 22. Restores the radio to the current operating status.

**APPENDIX B**

**Meter Functions**

Function	Parameter	Range/Units
AUDIO	Transmit audio on Exciter PWB Assy	-20 to +10 dB
LINE	Receive audio at output of Receiver PWB Assy	-20 to +10 dBm
PATCH	In REMOTE operation and if KEYED, line audio into Exciter PWB Assy will be monitored If KEYED, transmit audio input to Exciter PWB Assy	-20 to +10 dBm
FWD	If UNKEYED, receive audio output from Exciter PWB Assy If KEYED, forward RF output from Low Pass Filter PWB Assy	0 to 150 Watts
REF	If UNKEYED, relative receive signal strength (AGC Voltage) from AGC/TGC PWB Assy will be monitored If KEYED, reflected RF power at Low Pass Filter PWB Assy	0 to S9+60 dB
VSWR	If UNKEYED, relative signal strength If KEYED, VSWR computed from FWD and REF measurements	0 to 150 Watts
AFSK (if option installed)	If UNKEYED, relative signal strength Average received frequency relative to center tuned frequency at AFSK Keyer/Converter PWB Assy	1 to 4 ± the mark-to-space shift

## APPENDIX C

## Performance Specifications

## NOTE

The following specifications assume that all normal operating voltages are applied to the circuit board or assembly. No special test fixtures are required to measure the specifications, other than standard test equipment.

**Exciter PWB Assy  
10085-5400**

PARAMETER	TEST CONDITIONS	ADJUSTMENT	TEST POINT	SPECIFICATION
V Audio (meter)	1 KHz at 1 V rms into J10-30	R47	J7-21	1.10 $\pm$ 0.12 Vdc
Sidetone	Same as above	None	J6-8	0.050 $\pm$ 0.032 Vdc
V Line	1 KHz at 1 V rms into J9-4	MIC pot on XCVR front panel	J7-21	1.10 $\pm$ 0.12 Vdc
Line Input	1 KHz at 1 V rms into J10-47	R27	Same as above	Same as above
Audio 2	1 KHz at 1 V rms into J10-34/32	R29	Same as above	+0.075 Vdc
Patch Transmit	1 KHz at 1 V rms into J10-50	PATCH TX pot on XCVR front panel	Same as above	Same as above
Aux Receive	1 KHz at 1 V rms into J6-7	PATCH RX pot on XCVR front panel	J10-49	1.0 $\pm$ 0.07 Vac
Vox Gain	1 KHz at 1 V rms into J9-4	VOX pot on XCVR front panel	None	Radio keys
Antivox Gain	Same as above	ANTIVOX pot on XCVR front panel	None	Radio unkeys
Clipper	1 KHz at 1 V rms into J10-47	R91	TP3	2 V pk-pk
Balanced Modulator	Same as above; also, 455 KHz at -6 dBm into J1	R110, R117	P1	454 and 456 KHz at approx. -35 dBm; carrier should be null (40 dB down from tones); also, IMD must be -95 dBm or less



**Exciter PWB Assy (Continued)**  
**10085-5400**

PARAMETER	TEST CONDITIONS	ADJUSTMENT	TEST POINT	SPECIFICATION
40 MHz Transmit IF Output	40 MHz at -6 dBm into J2; 2 tones (454, 456 KHz at -24 dBm) into P2	C99	J3	Peak 40.455 MHz signal at $-2 \pm 3$ dBm; IM should be 45 dB down from peak
455 KHz IF Envelope	Same as above, except level of tones is -34 dBm	L7	J5-1	Peak signal at approx. +3.3 Vdc
AME Carrier Reinsertion	40 MHz at -6 dBm into J2; AME mode	R119	J3	-2 dBm
Coupler Tune	Same as above	R148	Same as above	-0.5 dBm
Low Power Indicator	No signal in; radio keyed	R254	J7-31	Logic high: approx. +4.25 Vdc

**IF Filter PWB Assy**  
**10085-5300**

PARAMETER	TEST CONDITIONS	ADJUSTMENT	TEST POINT	SPECIFICATION
IF Filter Input	455 KHz at -37 dBm into J1	L2	J5	Maximum output (approx. +4 dBm)
IF Gain	456.7 KHz at -37 dBm into J1	R5	J2	-19 dBm, with a low at Q8-C
	455 KHz at -37 dBm into J1	None	Same as above	$-18 \pm 2$ dBm, with a low at Q8-C
	453.2 KHz at -37 dBm into J1	None	Same as above	$-20 \pm 2$ dBm, with a low at Q8-C

**First Converter PWB Assy  
10085-5000**

PARAMETER	TEST CONDITIONS	ADJUSTMENT	TEST POINT	SPECIFICATION
LPF Nulling	59.3 MHz, 20 dBm signal into J1; JMP1 out; TGC = -6 Vdc AGC = 0 Vdc	L7	J7	Null
	Same as above, except freq. is 40.455 MHz	L8	Same as above	Same as above
	Same as above, except freq. is 44 MHz	L9	Same as above	Same as above
RX Output	Same as above, except freq. is 1.6 MHz at 30 dBm	None	Same as above	7 V pk-pk $\pm$ 3 V
	14 MHz at 0 dBm into J1; 54.455 MHz at 0 dBm into J5; JMP1 in	L17, L14	J2	40.455 MHz at more than 0 dBm
	Same as above, except AGC = -1.5 Vdc	R17	Same as above	20 $\pm$ 5 dB reduction in output
	1.6001 MHz at 0 dBm into J1; 42.0551 MHz at 0 dBm into J5; AGC = 0 Vdc	None	Same as above	40.455 MHz at more than 0 dBm
	29.999 MHz at 0 dBm into J1; 70.454 MHz at 0 dBm into J5; AGC = 0 Vdc	None	Same as above	40.455 MHz at more than 0 dBm
40 MHz IF Trap	40.455 MHz at -30 dBm into J5	L37	Same as above	Null

**First Converter PWB Assy (Continued)**  
**10085-5000**

PARAMETER	TEST CONDITIONS	ADJUSTMENT	TEST POINT	SPECIFICATION
TX Output	40.455 MHz at -10 dBm into J3; 54.455 MHz at 0 dBm into J5; TGC = -6 Vdc	None	J4	+6 dBm minimum
	Same as above, except TGC = 0 Vdc	None	Same as above	10 ±3 dB reduction in output
	Same as above, except TGC = +6 Vdc	None	Same as above	An additional 10 dB reduction in output
	40.455 MHz at -10 dBm into J3; 42.0551 MHz at 0 dBm into J5; TGC = -6 Vdc	None	Same as above	+6 dBm minimum
	Same as above, except 70.454 MHz at 0 dBm into J5	None	Same as above	+6 dBm minimum

**Power Amplifier PWB Assy**  
**10085-8100**

PARAMETER	TEST CONDITIONS	ADJUSTMENT	TEST POINT	SPECIFICATION
Bias Current	All pots fully CCW; PA keyed by grounding CR3-K; no input signal	R4	#14 AWG wire between E20 & E21	300 mA
	Same as above	R3	#18 AWG wire between E18 & E19	110 mA
	Same as above	R1	TP3	0.4 Vdc
Gain Slope	30 MHz at -30 dBm into J6; increase signal till output at J7 is 71 Vac (input level should be approx. 12 dBm); change frequency to 1.6 MHz; +13.6 Vdc at E13	R2	J7	71 Vac at 1.6 MHz

**Power Amplifier PWB Assy (Continued)  
10085-8100**

PARAMETER	TEST CONDITIONS	ADJUSTMENT	TEST POINT	SPECIFICATION
Current Limit	Same as above, except increase input level till 24 A is drawn; +13.6 Vdc at E13	R5	P1-3 side of R68	+5.0 Vdc
	Same as above, except reduce input level till output at J7 is 71 Vac	None	TP4	Approx. +4.0 Vdc

**Low Pass Filter PWB Assy  
10085-4000**

PARAMETER	TEST CONDITIONS	ADJUSTMENT	TEST POINT	SPECIFICATION
Tuning Nulls	Frequency (MHz)		J3 (RX) J2 (TX)	Minimum RF output voltage
Band 1	3.501	L14		
	4.019	L15		
	6.533	L13		
Band 2	5.56	L8		
	6.72	L9		
	11.47	L7		
Band 3	8.988	L5		
	10.565	L6		
	17.395	L4		
Band 4	14.479	L2		
	18.278	L3		
	29.972	L1		
Band 5	23.715	L11		
	28.657	L12		
	48.71	L10, C3, C4		
Band 6	36.725	L17		
	40.935	L18		
	69.275	L16, C5, C6		

**Low Pass Filter PWB Assy (Continued)**  
**10085-4000**

PARAMETER	TEST CONDITIONS	ADJUSTMENT	TEST POINT	SPECIFICATION
Return Loss: Bands 1-4		None	Same as above	-16 dB or better
Bands 5-6				-18 dB or better
Insertion Loss: Bands 1-4		None	Same as above	-.5 dB
Bands 5-6				-.6 dB
V Refl	15.0 MHz	R18	J6-1	Null
V Fwd	29.9 MHz	R17	J6-2	+8.0 ±0.05 Vdc
BIT Osc.: Frequency		C1	J3	2.45760 MHz
Output		R1	J3	-18 dBm

**AGC/TGC PWB Assy**  
**10085-5250**

PARAMETER	TEST CONDITIONS	ADJUSTMENT	TEST POINT	SPECIFICATION
TGC Differential	TP2 = +8 Vdc TP1 = +8 Vdc	R37	TP9	+180 mV
TGC Clock Frequency	TP2 = +8 Vdc	R119	TP6	32.768 KHz ±800 Hz
AGC Threshold	15.001 MHz at -103 dBm into J1 on XCVR; AGC: medium; XCVR set to 15.000 MHz USB; 1 KHz tone is audible	R167	TP11	0 ±0.1 Vdc

Receiver PWB Assy  
10085-5200

PARAMETER	TEST CONDITIONS	ADJUSTMENT	TEST POINT	SPECIFICATION
2nd LO Gain	40 MHz at 0 dBm into J4; 40.455 MHz at -40 dBm into J1; AGC = -6 Vdc	L6	J2	455 KHz at -36 dBm minimum
AGC	Same as above; adjust signal level at J1 for -10 dBm at J2	None	Same as above	-10 dBm
	Same as above, except AGC = -2 Vdc	None	Same as above	-18 to -14 dBm
	Same as above, except AGC = +4 Vdc	None	Same as above	-37.5 to -31.5 dBm
	Same as above, except AGC = +6 Vdc	None	Same as above	-53 to -47 dBm
AM Audio Level	AME mode; AGC off; full RF gain; 455 KHz at -80 dBm into J5	R42, L24	TP1	20 mV pk-pk minimum; should be 35 mV pk-pk
AGC	Same as above initially; then minimum RF gain; increase signal to -20 dBm into J5	R197	Same as above	20 mV pk-pk minimum; should be 35 mV pk-pk
AM Audio Level	Same as above, except 455 KHz at -74 dBm with a 1 KHz tone at 30% modulation; full RF gain	None	JMP2, E4	220 to 350 mV pk-pk
SSB Audio Level	USB mode; 455 KHz at 0 dBm into J7; 454 KHz at -80 dBm into J5	None	Same as above	200 to 380 mV pk-pk
Line Output	Same as above	LINE pot on front panel	P1-9	2.45 V rms (+10 dBm)
Audio 2 Output	Same as above	None	P1-12 or P1-13	1.06 V rms (+2.7 dBm)
Aux Audio Output	Same as above	None	P1-7	53-130 mV rms (-23.3 to -15.5 dBm)

**Receiver PWB Assy (Continued)  
10085-5200**

PARAMETER	TEST CONDITIONS	ADJUSTMENT	TEST POINT	SPECIFICATION
Headphone Output	Same as above; squelch off; full volume	None	J11-2	2.2 V rms (+9 dBm)
Speaker Output	Same as above	None	J11-7	4.5 V rms (+15.3 dBm)
Antivox Output	Same as above	None	P1-10	1.1 V rms $\pm$ 1 V (+3.05 dBm)
			P1-4	1.80 $\pm$ 0.05 Vdc
Sidetone Output	1 KHz at .2 V pk-pk into P1-8	R93	JMP2, E4	220-350 mV pk-pk

**Crystal Oscillator Assy  
10085-0610**

PARAMETER	TEST CONDITIONS	ADJUSTMENT	TEST POINT	SPECIFICATION
Output	+15 Vdc at E1 GND at E2 +13.6 Vdc at E3	None	SMB output connector	10.00000 MHz sine wave at 0.6 to 1.0 V pk-pk
Frequency	Same as above	Variable capacitor under screw	Same as above	10.00000 MHz $\pm$ offset

**REF/BFO PWB Assy  
10085-5500**

PARAMETER	TEST CONDITIONS	ADJUSTMENT	TEST POINT	SPECIFICATION
40 MHz Reference Output	10 MHz at 1.0 V pk-pk into J2	L14	Case of Q21 with 10x scope probe	Peak reading: greater than 550 mV pk-pk at 40.00000 MHz
	Same as above	L1, L2	J3, J4	Peak reading: 0 $\pm$ 3 dBm at 40.00000 MHz

REF/BFO PWB Assy (Continued)  
10085-5500

PARAMETER	TEST CONDITIONS	ADJUSTMENT	TEST POINT	SPECIFICATION
200 KHz Reference Output	Same as above	None	P2	4.25 $\pm$ 0.25 V pk-pk, 200 KHz square wave
1 KHz Reference Output	Same as above	None	J5	0.24 $\pm$ 0.06 V pk-pk, 1 KHz sine wave
BFO Output	Same as above	None	J7	Approx. 0.74 V pk-pk, 455.00 KHz sine wave
VCO	Same as above	C35	TP1	+6.5 Vdc
Carrier Output	Same as above	None	J6	0.5 $\pm$ 0.3 V pk-pk, 455.00 KHz sine wave
Aux Carrier Output	Same as above	None	J9	40 $\pm$ 20 mV pk-pk, 455.00 KHz sine wave

Synthesizer PWB Assy  
10085-5600

PARAMETER	TEST CONDITIONS	ADJUSTMENT	TEST POINT	SPECIFICATION
Output	200 KHz, TTL level square wave into J1; Synthesizer frequency set to 45.00000 MHz	None	P1	45.00000 MHz at -3 dBm
Reference Sideband Level	Same as above; set analyzer to 45.1 MHz at 2 KHz SCAN/DIV with REF level at -10 dBm	R2	Same as above	Minimum level: should be less than -60 dBm
40.455 MHz Trap	Same as above, except change Synthesizer frequency to 40.455 MHz	L8 on VCO Board	Same as above	Null; level should be less than -14 dBm



**Multivoltage Supply Assy  
10085-1240**

PARAMETER	TEST CONDITIONS	ADJUSTMENT	TEST POINT	SPECIFICATION
-15 Vdc Output	+10.0 to +35 ±2 Vdc input with full load at all outputs: -15 Vdc = 0.5 A +15 Vdc = 1.7 A +5 Vdc = 2.5 A	None	E2	-14.85 to -15.3 Vdc
+15 Vdc Output		R4	E3	+15.0 Vdc
+5 Vdc Output		R61	E6	+5.0 Vdc

**Audio Interface PWB Assy  
10085-0570**

PARAMETER	TEST CONDITIONS	ADJUSTMENT	TEST POINT	SPECIFICATION
Patch Transmit Output	1 KHz, 0 dBm into J1-5	None	J1-10	-10.8 ±1 dBm in 2W position; -11.0 ±1 dBm in 4W position
Line Balance	Same as above	R5	J1-7	Null (should be less than -40 dBm)
Line In Output	1 KHz, 0 dBm into J1-9	None	Same as above	-10.8 ±1 dBm in 2W position; -11.0 ±1 dBm in 4W position
Patch Balance	Same as above	R1	J1-10	Null (should be less than -40 dBm)

**ASFK Keyer/Converter PWB Assy  
10085-6100**

PARAMETER	TEST CONDITIONS	ADJUSTMENT	TEST POINT	SPECIFICATION
Oscillator Frequency	AFSK mode	C22	TP3	1.24890 MHz ±100 Hz
TTL DC Offset	1 KHz at 50 mV rms into J2-19; AFSK shift of 170 Hz	R8	TP1	Equally spaced pulses
Duty Cycle Balance	Same as above, except signal level is 100 mV rms	R21	TP2	Symmetrical 2 KHz signal ±12 Vdc relative to ground
Meter Balance	Same as above	R86	Junction of R87 and R88	+2.5 ±0.05 Vdc
Detector Threshold	Same as above, except signal level is 5 mV rms	R73	AR7-1	Positive transition to +13.6 Vdc

**ASFK IF Filter PWB Assy  
10085-6200**

PARAMETER	TEST CONDITIONS	ADJUSTMENT	TEST POINT	SPECIFICATION
Output	<p>S1 to 850 Hz; S2 to USB; signal into P1: 455.50 KHz/0 dBm 454.50 KHz/0 dBm</p> <p>S1 to 170 Hz; signal into P1: 454.50 KHz/0 dBm 454.90 KHz/0 dBm 455.10 KHz/0 dBm</p> <p>S1 to 85 Hz; signal into P1: 455.10 KHz/0 dBm 455.05 KHz/0 dBm 454.95 KHz/0 dBm</p>	None	P2	<p>-19 dBm -19 dBm</p> <p>-30 dBm -19 dBm -19 dBm</p> <p>-20 dBm -19 dBm -19 dBm</p>

**+13.6 V Power Supply  
10085-0260**

PARAMETER	TEST CONDITIONS	ADJUSTMENT	TEST POINT	SPECIFICATION
Output Voltage	+17 ±1 Vdc to +35.5 ±1 Vdc input at full load (20 A)	R26	+ side of C5	+13.6 ±0.05 Vdc with a max. ripple of 50 mVac
Output Voltage	Same as above, except CW or AFSK mode is selected	R28	Same as above	+12.3 ±0.05 Vdc with a max. ripple of 50 mVac



## CHAPTER 7

### ILLUSTRATED PARTS BREAKDOWN

#### Section 1. INTRODUCTION

**7-1. PURPOSE.** This chapter lists, illustrates, and describes the detail parts for the 100 Watt Transceiver. Its purpose is for the identification, requisitioning, and issuance of parts at the depot level.

**7-2. SCOPE.** Bulk electrical items, such as terminals, wire, heat shrink tubing, etc., are not listed in this manual. Common hardware items, such as screws, washers, nuts, etc., when used to attach structural components that are not normally removed or disassembled, are also not listed. In general, the parts installed at the time the 100 Watt Transceiver was manufactured are listed and identified in this chapter. When a part (including vendor items), which is different from the original, was installed during the manufacture of later items, series, or blocks, all parts are listed (and "Usable-On" coded). However, when the original part does not have continued application (no spares of the original were procured or such spares are no longer authorized for replacement), only the preferred part is listed. Also, when a part was installed during modification, and the original does not have continued application, only the preferred item is listed. Interchangeable and substitute parts, subsequently authorized by the Government, are not listed in this chapter; such items are identified by information available through the Interchangeable and Substitute (I & S) Data Systems. Refer to T.O. 00-25-184. When a standard size part can be replaced with an oversize or undersize part, the latter parts, showing sizes, are also listed. Repair Parts Kits

and Quick Change Units are listed when they are available for replacement.

**7-3. CHAPTER ORGANIZATION.** This chapter is divided into two sections. Section I, INTRODUCTION, explains the purpose, scope, and organization of the chapter. Section II, MAINTENANCE PARTS LIST, consists of illustrations, in which the detail parts of the 100 Watt Transceiver are identified by numbers (called index numbers), followed by lists which contain parts numbers, descriptions, and other relevant data for the items identified on the illustrations. Section II also contains two other lists: A numerical index, which lists the parts in alphanumerical sequence; and a reference designator index, which lists the electrical parts in alphabetical sequence by their reference designators.

**7-4. SOURCE, MAINTENANCE, AND RECOVERABILITY (SMR) CODES.** This chapter contains Air Force Peculiar In-Being Source and Repair Codes only. Definitions of these SMR codes, as well as detailed coding criteria and transposition matrices for each coding method, may be obtained from T.O. 00-25-195. Refer to page 7-13.

**7.5. FEDERAL SUPPLY CODES FOR MANUFACTURERS (FSCM).** The codes used in this chapter are as follows. The first list is in numerical order by FSCM; the second is in alphabetical order by manufacturer name.

**T.O. 31R2-2URC-83**

FSCM	NAME AND ADDRESS				
00000	Ordnance Corps The Defense Logistics Services Center	02660	Bunker Ramo-Eltra Corporation Amphenol Division 2801 S. 25th Avenue Broadview, IL 60153	06980	Varian Associates, Inc. EIMAC Division 301 Industrial Way San Carlos, CA 94070
00141	PIC Design Corporation Division of Wells-Berarus Corporation Benson Road P.O. Box 1004 Middlebury, CT 06762	02735	RCA Corporation Solid State Division Route 202 Somerville, NJ 08876	07263	Fairchild Camera and Instrument Corporation Semiconductor Division Subsidiary of Schlumberger LTD North American Sales Mail Stop 14-1053 401 Ellis Street P.O. Drawer 7284 Mountain View, CA 94042
00159	Acme Electric Corporation Cuba, NY	02768	Illinois Tool Works, Inc. Fastex Division 195 Algonquin Road Des Plaines, IL 60016	07707	USM Corporation Subsidiary of Emhart Industries, Inc. USM Fastener Division 510 River Road Shelton, CT 06484
00213	Nytronics Components Group, Inc. Subsidiary of Nytronics Inc. Orange Street Darlington, SC 29532	03508	General Electric Company Semi-Conductor Products Department W. Genesee Street Auburn, NY 13021	07858	Arrow Hart Canada LTD Scarborough, Ontario Canada M8Z 2R4
00348	Microtran Co., Inc. 145 E. Mineola Avenue P.O. Box 236 Valley Stream, NY 11582	03888	Pyrofilm Division Division of KDI Electronics Inc. 60 S. Jefferson Road Whippany, NJ 07981	08289	Blinn Delbert Company, Inc The 1678 E. Mission Blvd. P.O. Box 2007 Pomona, CA 91769 5065
00493	Sargent Art Division of Mead Corporation Hazleton, PA	04009	Crouse-Hinds Arrow Hart Inc. Arrow Hart Division 103 Hawthorn Street Hartford, CT 06105	08484	Breeze-Eastern Corporation Subsidiary of Transtechnology Corporation 700 Liberty Avenue Union, NJ 07083
00752	Eaton Corporation AIL Division Lond Island Plants Commack Road Deer Park, L.I., NY 11729	04222	AVX Ceramics Division of AVX Corporation 19th Avenue South P.O. Box 867 Myrtle Beach, SC 29577	08544	United Shoe Machinery Corporation Cincinnati, OH
00758	Neilsen Products Company Lake Elmo, MN	04386	Liton Industries, Inc. Liton Systems Inc. Triad-Utrad Division 305 N. Briant Street Huntington, IN 46750	08779	Signal Transformer Company, Inc. 500 Bayview Avenue Inwood, NY 11696
00779	AMP, Inc. 2800 Fulling Mill P.O. Box 3608 Harrisburg, PA 17105	04426	Licon Division of Illinois Tool Works, Inc. 6615 W. Irving Park Road Chicago, IL 60634	09023	Cornell-Dubilier Electronics 118 E. Jones Street Fuquay-Varina, NC 27526
00853	Sangamo Weston, Inc. Sangamo Capacitor Division Subsidiary of Schlumberger LTD Sangamo Road P.O. Box 128 Pickens, SC 29671	04713	Motorola, Inc. Semiconductor Products Sector 5005 E. McDowell Road Phoenix, AZ 85008	09166	Stone City Products, Inc. 1206 7th Street P.O. Box 369 Bedford, IN 47421
01009	Alden Products Company 117 N. Main Street P.O. Box 860 Brockton, MA 02403	05326	General Electric Company Aviation Service Operation/CINTI 333 W. Seymour Avenue Cincinnati, OH 45216	09214	General Electric Company Semi-Conductor Products Department Power Components Operation W. Genesee Street Auburn, NY 13021
01295	Texas Instruments Inc. Semiconductor Group 13500 N. Central Expressway P.O. Box 225012 M/S 49 Dallas, TX 75265	05828	General Instrument Corporation Government Systems Division 600 W. John Street Hicksville, NY 11802	09353	C and K Components, Inc. 15 Riverdale Avenue Newton, MA 02158
01961	Varian Associates, Inc. Pulse Engineering Subsidiary 7250 Convoy CT P.O. Box 12235 San Diego, CA 92112	06090	Raychem Corporation 300 Constitution Drive Menlo Park, CA 94025	10026	CSI Capacitors A Division of CSI Technologies, Inc. Del Dios Highway P.O. Box 2052 Escondido, CA 92025
02111	Spectrol Electronics Corporation Subsidiary of Carrier Corporation 17070 E. Gale Avenue P.O. Box 1220 City of Industry, CA 91749	06383	Panduit Corporation 17301 Ridgeland Tinley Park, IL 60477	10054	Marson Corp 130 Crescent Avenue Chelsea, MA 02150
02114	Amperex Electronic Corporation Ferroxcube Division 5083 Kings HWY Saugerties, NY 12477	06402	E-T-A Circuit Breakers 7400 N. Croname Road Chicago, IL 60648	11195	Magna Division Vermont American Corporation 1001 West Park Road Elizabethtown, KY 42701
02289	HI-G Company Subsidiary of Nytronics Inc. 101 Locust Street Hartford, CT 06114	06540	Mite Corporation Amatom Electronic Hardware Division 446 Blake Street New Haven, CT 06515	11236	CTS of Berne, Inc. 406 Parr Road Berne, IN 46711

11897	Plastiglide Manufacturing Corporation 2701 W. El Segundo Blvd. Hawthorne, CA 90250	16546	Centralab, Inc. A North American Phillips Company 4561 Colorado Los Angeles, CA 90039	21340	ITT Telecom Products Corporation Network Systems Division HWY 137 Suncrest Drive P.O. Box N Carroll Reece Station Johnson City, TN 37601
12040	National Semiconductor Corporation Commerce Drive P.O. Box 443 Danbury, CT 06810	16733	Cablewave Systems, Inc. 60 Dodge Avenue North Haven, CT 06473	22526	Du Pont E I De Nemours and Company, Inc. Photo Products Department Berg Electronics Division Route 83 New Cumberland, PA 17070
12909	Cardion Electronics Division of General Signal Controls, Inc. A Unit of General Signal Corporation Long Island Expressway Woodbury, NY 11797	16741	Triad Transformer Corporation Huntington, IN	22701	Bestran Corporation Dilectron Division 2869 So. Myrtle Avenue Monrovia, CA 91016
12969	Unitrode Corporation 580 Pleasant Street Watertown, MA 02172	17117	Electronic Molding Corporation 96 Mill Street Woonsocket, RI 02895	22903	Singer Company The Link Flight Simulation Division Advanced Products Operation 1077 E. Arques Avenue P.O. Box 3484 Sunnyvale, CA 94088
13103	Thermalloy Company, Inc. 2021 W. Valley View Lane P.O. Box 340839 Dallas, TX 75234	17856	Siliconix, Inc. 2201 Laurelwood Road Santa Clara, CA 95054	24446	General Electric Company 3135 Easton Turnpike Fairfield, CT 06431
13499	Rockwell International Corporation Collins Telecommunications Products Division Defense Electronics Operations 855 NE 35th Street Cedar Rapids, IA 52498	18212	American Trans-Coil Corporation 124-06 101st Avenue Richmond Hill, NY 11419	24546	Corning Glass Works 550 High Street Bradford, PA 16701
13764	Micro Plastics, Inc. HWY 178 N. Flippin, AR 72634	18324	Signetics Corporation Military Products Division 4130 S. Market Court Sacramento, CA 95834	25330	General Connector Corporation Subsidiary of the Union Corporation 80 Bridge Street Newton, MA 02158
14304	Harris Corporation RF Communications Division 1680 University Avenue Rochester, NY 14610	18722	RCA Corporation Solid State Division Crestwood Road Mountaintop, PA 18707	25403	Amperex Electronic Corporation Semiconductor Solid State and Active Devices-Electro Optical Devices Providence Pike Slatersville, RI 02876
14519	Designatronics, Inc. 55 S. Denton Avenue New Hyde Park, NY 11040	18796	Murato Erie Technological Products State College Operations 1900 W. College Avenue State College, PA 16801	26066	Minnesota Mining and Manufacturing Company Industrial Tape Division 3M Center St Paul, MN 55101
14655	Cornell-Dubiler Electronics Division of Federal Pacific Electric Company Government Contracts Department 150 Ave L Newark, NJ 07101	18876	Department of Army U.S. Army Missile Command Redstone Arsenal, AL 35809	26344	Mite Corporation 466 Blake Street New Haven, CT 06515
14674	Corning Glass Works Houghton Park Corning, NY 14830	18915	Birtcher Corporation The Industrial Division 4501 N. Arden Drive P.O. Box 4399 El Monte, CA 91734	26667	Liton Industries, Inc. Triad Distributor Division Huntington, IN
14933	Defense Electronics Supply Center Dayton, OH 45401	19200	U.S. Army Armament Research and Development Command Dover, NJ 07801	27014	National Semiconductor Corporation 2900 Semiconductor Drive Santa Clara, CA 95051
15542	Mini-Circuits Laboratory Division of Scientific Components Corporation 2625 E. 14th Street Brooklyn, NY 11235	19207	U.S. Army Tank Automotive Command Warren, MI 48090	27264	Molex, Inc. 2222 Wellington Court Lisle, IL 60532
15801	Fenwal Electronics Division of Kidde Walter and Company, Inc. 63 Fountain Street Framingham, MA 01701	19396	Illinois Tool Works, Inc. Paktron Division 900 Follin Lane S.E. Vienna, VA 22180	27777	Varo, Inc. Electron Devices Division 2203 Walnut Street P.O. Box 401146 Garland, TX 75040
15912	T and B/Ansley Corporation Subsidiary of Thomas and Betts Corporation 4371 Valley Blvd. Los Angeles, CA 90031	19647	Caddock Electronics, Inc. 1717 Chicago Avenue Riverside, CA 92507	28124	Minnesota Mining and Manufacturing Company Industrial Coated Abrasives Division 3M Center St. Paul, MN 55101
15969	Dixie Chemical Company 3635 W. Dallas Street Houston, TX 77019	19701	Mepco/Electra, Inc. A North American Phillips Company P.O. Box 760 Mineral Wells, TX 76067		
		21052	High Energy Corporation Subsidiary of Inductotherm Corporation Lower Valley Road Parkesburg, PA 19365		
		21317	Electronic Applications Company 4918 Santa Anita Avenue El Monte, CA 91734		

**T.O. 31R2-2URC-83**

28480	Hewlett-Packard Company Corporate HQ 3000 Hanover Street Palo Alto, CA 94304	34649	Intel Corporation 3065 Bowers Avenue Santa Clara, CA 95051	54254	Minnesota Mining and Manufacturing Company Data Recording Products Division 350 S. Lewis Road Camarillo, CA 93010
28482	Electronic Laboratory Supply Company 7208 Germantown Avenue Philadelphia, PA 19119	34899	Fair-Rite Products Corporation 1 Commercial Row Walkill, NY 12589	54473	Matsushita Electric Corporation of America One Panasonic Way P.O. Box 1501 Secaucus, NJ 07094
28520	Heyco Molded Products 1750 Blvd. P.O. Box 160 Kenilworth, NJ 07033	37695	Magnavox Government and Industrial Electronics Co. 1313 Production Road Fort Wayne, IN 46808	54904	Eltra Corporation Subsidiary of Allied Chemical Company Medwec Division 105 Skyport Drive P.O. Box 417 Scottsbluff, NE 69361
29964	Allied Devices Corporation 2365 Milburn Avenue P.O. Drawer E. Baldwin, NY 11510	44122	LXD 24500 High Point Road Cleveland, OH 44122	55002	Power Conversion, Inc. 495 Boulevard Elmwood Park, NJ 07407
30142	Minnesota Mining and Manufacturing Company Energy Systems 3M Center Bldg. 551 St. Paul, MN 55101	44655	Ohmite Manufacturing Company 3601 W. Howard Street Skokie, IL 60076	55285	The Bergquist Company, Inc. 5300 Edina Industrial Blvd. Minneapolis, MN 55435
31433	Union Carbide Corporation Electronics Division HWY 276 SE P.O. Box 5928 Greenville, SC 29606	46384	Penn Engineering and Manufacturing Corporation Old Easton Road P.O. Box 1000 Danboro, PA 18916	55322	Samtec, Inc. 810 Progress Blvd. P.O. Box 1147 New Albany, IN 47150
31922	Leeds and Northrup Company A Unit of General Signal Corporation Summeytown Pike North Wales, PA 19454	49671	RCA Corporation 30 Rockefeller Plaza New York, NY 10020	55566	R A F Electronic Hardware, Inc. 95 Silvermine Road Seymour, CT 06483
32039	Zeus Industrial Products, Inc. Ft. Thompson Street Raritan, NJ 08869	50157	Midwest Components, Inc. 1981 Port City Blvd. P.O. Box 787 Muskegon, MI 49443	56289	Sprague Electric Company 87 Marshall Street North Adams, MA 01247
32097	PCC Pertec Division Pertec Computer Corporation 9600 Irondale Avenue Chatsworth, CA 91311	50173	Curt Straub Enterprises 444 W. Ocean Blvd. Suite 1106 Long Beach, CA 90802	56637	RCD Components, Inc. 330 Bedford Street Manchester, NH 03101
32284	Rotron Controls Division Rotron, Inc. Woodstock, NY	50434	Hewlett-Packard Company Optoelectronics Division 640 Page Hill Road Palo Alto, CA 94304	56699	Mepeco/Electra, Inc. 6071 St. Andrews Road Columbia, CS 29210
32293	Intersil Inc. Subsidiary of General Electric Company 10710 N. Tantau Avenue Cupertino, CA 95014	51144	IDI Electric Canada LTD 33 Fuller Road Box 159 Ajax, Ontario Canada L1S 2E1	57074	Alberox Corporation New Bedford, MA
32848	Thompson Industries Division of W M F Container Corporation 2501 E. Magnolia Street Phoenix, AZ 85036	51984	NEC America, Inc. 2741 Prosperity Avenue Fairfax, VA 22031	57285	Millen Division Electronic Instrument and Specialty Corporation 42 Pleasant Street Stoneham, MA 02180
32890	Luminescent Systems Inc. Etna Road Grafton County Lebanon, NH 03766	52458	Magnum Electric Corporation 6385 Dixie HWY Erie, MI 48133	57771	Stimpson Company, Inc. 900 Sylvan Avenue Bayport, NY 11705
32997	Bourns, Inc. Trimpot Division 1200 Columbia Avenue Riverside, CA 92507	52559	Metraplex Corporation Berkshire Industrial Park Bldg. 3 Bethel, CT 06801	57921	Bourns, Inc. Precisions/Controls Division 1200 Columbia Avenue Riverside, CA 92507
34335	Advanced Micro Devices 901 Thompson Place Sunnyvale, CA 94086	52760	Minnesota Mining and Manufacturing Company Electro Products Division 341 Factory Road Addison, IL 60101	57922	Bourns, Inc. Precisions/Controls Division 1200 Columbia Avenue Riverside, CA 92507
34553	Amperex Electronic Corporation Component Division Hauppauge, NY	53373	Midland-Ross Corporation Cambion Division Barnstead Road Pittsfield, NH 03263	57924	Bourns, Inc. Networks Division 12155 Magnolia Avenue Riverside, CA 92503
		53894	Aham, Inc. 27901 Front Street Rancho California, CA 92390	58167	Palco Connector, Inc. 75 Center Street Bristol, CT 06010



59076	Designatronics, Inc. Stock Drive Products Division 55 S. Denton Avenue New Hyde Park, NY 11040	63312	Endicott Research Group, Inc. 2601 Wayne Street P.O. Box 269 Endicott, NY 13760	72819	Carborundum Company The Electrical Products Division Globar Plant 3425 Hyde Park Blvd. P.O. Box 339 Niagara Falls, NY 14302
59730	Thomas and Betts Corporation HWY 218 S. Iowa City, IA 52240	70485	Atlantic India Rubber Works, Inc. 571 W. Polk Street Chicago, IL 60607	72835	Gochenaour Marine Company Philadelphia, PA
59950	Shielding Technology, Inc. Subsidiary of Chomerics, Inc. 120 Ethel Road W. Piscataway, NJ 08854	70494	Emhart Industries, Inc. Hardware Division 225 Episcopal Road Berlin, CT 06037	72962	Amerace Corporation Esna Division 2330 Vauxhall Road Union, NJ 07083
59993	International Rectifier Semiconductor Division 233 Kansas Street El Segundo, CA 90245	70903	Belden Corporation Subsidiary of Cooper Industries, Inc. 2000 S. Batavia Avenue Geneva, IL 60134	72982	Murata Erie North America, Inc. Erie Operations 645 W. 11th Street Erie, PA 16512
60705	Cera-Mite Corporation 1327 6th Avenue Grafton, WI 53024	70983	Bethlehem Steel Corporation Shipbuilding Department Room 1000 Martin Tower Bethlehem, PA 18016	73138	Beckman Instruments, Inc. Beckman Electronic Technologies Subsidiary of Smith Kline/Beckman Corporation 2500 Harbor Blvd. Fullerton, CA 92634
60963	Niagara Straw Company, Inc. 72 Lakeview Avenue Buffalo, NY 14201	71041	Incom International, Inc. Boston Gear Division, Inc. 14 Hayward Street Quincy, MA 02171	73734	Federal Screw Products, Inc. 3917 N. Kedzie Avenue Chicago, IL 60618
61306	Silvered Electronic Mica Company, Inc. RT 6 Willimantic, CT 06226	71279	Midland-Ross Corporation Cambion Division One Alewife Place Cambridge, MA 02140	73899	JFD Electronic Components A Division of Murata Erie North America 112 Mott Street Oceanside, NY 11572
61429	Fox Electronics Fox Enterprises, Inc. P.O. Box 1078 Cape Coral, FL 33910	71400	Bussmann Division of McGraw-Edison Company 114 Old State Road P.O. Box 14460 St. Louis, MO 63178	73905	ITT Jennings 970 McLaughlin Avenue San Jose, CA 95116
61463	Uniroyal, Inc. Oxford Management and Research Center Benson Road Middlebury, CT 06749	71450	CTS Corporation 905 N. West Blvd. Elkhart, IN 46514	73988	The Harrington And King Perforating Company, Inc. 5655 Fillmore Street Chicago, IL 60644
61529	Aromat Corporation 250 Sheffield Street Mountainside, NJ 07092	71468	ITT Cannon Electric Division of International Telephone and Telegraph Corporation 10550 Talbert Avenue P.O. Box 8040 Fountain Valley, CA 92708	74199	Quam Nichols Company 218 E. Marquette Road Chicago, IL 60637
61587	Hughes Electronic Devices Corporation 13321 Grass Valley Avenue P.O. Box 185 Grass Valley, CA 95945	71785	TRW, Inc. TRW Cinch Connectors Division 1501 Morse Avenue Elk Grove Village, IL 60007	74276	General Instrument Corporation Lamp Division/Worldwide 4433 N. Ravenswood Avenue Chicago, IL 60640
61725	ITT Components Division International Telephone and Telegraph Corporation 3201 S. Standard Street P.O. Box 2197 Santa Ana, CA 92707	71895	DeJavan Corporation 811 Fourth Street P.O. Box 100 West Des Moines, IA 50265	74840	Illinois Capacitor, Inc. 3757 W. Touhy Avenue Lincolnwood, IL 60645
61735	Pulse Engineering, Inc. 5004 Lehigh Road College Park, MD 20740	72136	Electro Motive Corporation Subsidiary of International Electronics Corporation Florence, SC	74868	Amphenol RF Operations An Allied Company 33 E. Franklin Street Danbury, CT 06810
61802	Toshiba Internation Industrial Division 13131 W. Little York Road P.O. Box 40906 Houston, TX 77041	72619	Dialight Division Ampere Electronic Corporation 203 Harrison Place Brooklyn, NY 11237	74970	Johnson EF Company 299 10th Avenue SW Waseca, MN 56093
61957	USM Corporation Subsidiary of Emhart Industries, Inc. 140 Federal Street Boston, MA 02107	72634	Dielectric Products Company, Inc. Jersey City, NJ	75042	TRW, Inc. TRW Electronic Components IRC Fixed Resistors Philadelphia Division 401 N. Broad Street Philadelphia, PA 19108
62703	Varo Semiconductor, Inc. Subsidiary of Varo, Inc. 1000 N. Shiloh Road P.O. Box 40676 Garland, TX 75040	72794	Dzus Fastener Company, Inc. 425 Union Blvd. West Islip, NY 11795	75263	Keystone Carbon Company 1935 State Street St. Marys, PA 15857

**T.O. 31R2-2URC-83**

75378	CTS Knights, Inc. 400 Reimann Avenue Sandwich, IL 60548	80045	Cincinnati Electronics Corporation Subsidiary of GEC, Inc. An English Electric Corporation Company 2630 Glendale-Milford Road Cincinnati, OH 45241	83325	SNC Manufacturing Company, Inc. 101 Waukau Road Oshkosh, WI 54901
75382	Kulka Electric Corporation A North American Philips Corporation Mt. Vernon, NY	80063	U.S. Army Communications And Electronics Materiel Readiness Command Logistics Engineering Directorate Fort Monmouth, NJ 07703	83330	Kulka Smith, Inc. A North American Philips Company 1913 Atlantic Avenue Manasquan, NJ 08736
75915	Tracor Littelfuse, Inc. 800 E. Northwest HWY Des Plaines, IL 60016	80101	General Electronics, Inc. Paterson, NJ	84830	Lee Spring Company, Inc. 1462 62nd Street Brooklyn, NY 11219
76301	McDonnell Douglas Corporation McDonnell Aircraft Company P.O. Box 516 St. Louis, MO 63166	80103	Veeco Instruments, Inc. Lambda Electronics Division 515 Broad Hollow Road Melville, NY 11747	86797	Rogan Corporation 3455 Woodhead Drive Northbrook, IL 60062
76385	Minor Rubber Company, Inc. 49 Ackerman Street Bloomfield, NJ 07003	80294	Bourns Instruments, Inc. 135 Magnolia Avenue Riverside, CA 92506	86928	Seastrom Manufacturing Company, Inc. 701 Sonora Avenue Glendale, CA 91201
76490	Moto Meter Gauge and Equipment Division Electric Auto Lite Company New York, NY	80372	Marine Corps. Navy Annex Washington, DC 20380	89032	Eaton Corporation Engineered Fasteners Division 8700 Brookpark Road P.O. Box 6688 Cleveland, OH 44101
77264	Phoenix Specialty Manufacturing Company, Inc. 971 Stewart Avenue Garden City, LI, NY 11530	81073	Grayhill, Inc. 561 Hillgrove Avenue P.O. Box 10373 La Grange, IL 60525	89110	AMP, Inc. Capitron Division 1595 S. Mt. Joy Street Elizabethtown, PA 17022
77342	AMF, Inc. Potter and Brumfield Division 200 Richland Creek Drive Princeton, IN 47671	81095	Triad-Utrad Division Litton Systems, Inc. National City, CA	89265	AMF, Inc. Potter and Brumfield Division 200 Richland Creek Drive Princeton, IN 47671
77347	Poulsen and Wardon, Inc. Los Angeles, CA	81249	Library Efficiency Corporation New York, NY	90372	Wakefield Engineering Company P.O. Box 818 Coeur D Alene, ID 83814
77609	RCA Corporation RCA Service Company RTE 38 Cherry Hill, NJ 08358	81349	Mil Spec	91506	Augat, Inc. 33 Perry Avenue P.O. Box 799 Attleboro, MA 02703
77820	Allied Amphenol Products Bendix Connector Operations 40-60 Delaware Street Sidney, NY 13838	81483	International Rectifier 9220 Sunset Blvd. Los Angeles, CA 90069	91836	Kings Electronics Company, Inc. 40 Marbledale Road Tuckahoe, NY 10707
78488	The Stackpole Corporation 201 Stackpole Street St. Marys, PA 15857	81564	Artted Company, Inc. 50 Warehouse Street Springfield, MA 01118	91929	Honeywell, Inc. Micro Switch Division 11 W. Spring Street Freeport, IL 61032
79061	Vaco Products Company 1510 Skokie Blvd. Northbrook, IL 60062	81814	Zierick Manufacturing Company Radio Circle Mt. Kisco, NY 10549	92891	Alliance Engineering, Inc. Alliance, OH
79136	Waldes Kohinoor, Inc. 47-16 Austel Place Long Island City, NY 11101	82389	Switchcraft, Inc. Subsidiary of Raytheon Company 5555 N. Elston Avenue Chicago, IL 60630	92967	Hutchens Industries, Inc. 215 N. Patterson Avenue P.O. Box 1427 SSS Springfield, MO 65805
79218	Waterous Company 300 John E. Carroll Avenue E. South St. Paul, MN 55075	82415	Alpax Corporation Frederick Division A North American Philips Company Husky Park P.O. Box 500 Frederick, MD 21701	93958	Republic Electronics Corporation 176 E. 7th Street Paterson, NJ 07524
79963	Zierick Manufacturing Company Radio Circle Mt. Kisco, NY 10549	82877	Rotron, Inc. Custom Division 7 Hasbrouck Lane Woodstock, NY 12498	94033	Lapointe Industries, Inc. Electronic Products Division 155 W. Main Street Rockville, CT 06066
80009	Tektronix, Inc. 4900 SW Griffith Drive P.O. Box 500 Beaverton, OR 97077	83014	Hartwell Corporation 900 S. Richfield Road Placentia, CA 92670	94117	Sanders Associates, Inc. Daniel Webster HWY South Nashua, NH 03061
80031	Mepco/Electra, Inc. 22 Columbia Road Morristown, NJ 07960	83079	Amerace Corporation Buchanan Crimptool Products Division 1065 Floral Avenue Union, NJ 07083	94222	Southco, Inc. 210 N. Brinton Lake Road Concordville, PA 19331

94464	Masstech Corporation Subsidiary of Transtechnology Corporation Swamp Road RT 313 P.O. Box 2001 Doylestown, PA 18901	99256	PEM Engineering Company Los Angeles, CA		AMP, Inc. 2800 Fulling Mill P.O. Box 3608 Harrisburg, PA 17105	00779
		99313	Varian Associates, Inc. Microwave Tube Division 611 Hansen Way Palo Alto, CA 94303		Amperex Electronic Corporation Component Division Hauppauge, NY	34553
94696	Magnecraft Electric Company 5575 N. Lynch Avenue Chicago, IL 60630		<b>NAME AND ADDRESS</b>	<b>FSCM</b>	Amperex Electronic Corporation Ferroxcube Division 5083 Kings HWY Saugerties, NY 12477	02114
95146	Alco Electronic Products, Inc. 1551 Osgood Street North Andover, MA 01845		Acme Electric Corporation Cuba, NY	00159		
95275	Vitramon, Inc. Box 544 Bridgeport, CT 06601		Advanced Micro Devices 901 Thompson Place Sunnyvale, CA 94086	34335	Amperex Electronic Corporation Semiconductor Solid State and Active Devices-Electro Optical Devices Providence Pike Slatersville, RI 02876	25403
95987	WH Brady Company 727 W. Glendale Avenue Milwaukee, WI 53209		Aham, Inc. 27901 Front Street Rancho California, CA 92390	53894		
96214	Texas Instruments, Inc. Equipment Group 13500 N. Central EXPY P.O. Box 660246 M/S 3137 Dallas, TX 75266		Airpax Corporation Frederick Division A North American Philips Company Husky Park P.O. Box 500 Frederick, MD 21701	82415	Amphenol RF Operations An Allied Company 33 E. Franklin Street Danbury, CT 06810	74868
96238	Dataproducs New England, Inc. Barnes Park North Wallingford, CT 06492		Alberox Corporation New Bedford, MA	57074	Aromat Corporation 250 Sheffield Street Mountainside, NJ 07092	61529
96804	Bell Industries, Inc. JW Miller Division 19070 Reyes Avenue P.O. Box 5825 Compton, CA 90224		Alco Electronic Products, Inc. 1551 Osgood Street North Andover, MA 01845	95146	Arrow Hart Canada LTD Scarborough, Ontario Canada M6Z 2R4	07858
96906	Mil Spec		Alden Products Company 117 N. Main Street P.O. Box 860 Brockton, MA 02403	01009	Artted Company, Inc. 50 Warehouse Street Springfield, MA 01118	81564
97520	Basler Electric Company RT 143 P.O. Box 269 Highland, IL 62249		Alliance Engineering, Inc. Alliance, OH	92891	Atlantic India Rubber Works, Inc. 571 W. Polk Street Chicago, IL 60607	70485
97942	Westinghouse Electric Corporation Defense and Electronic Systems Center Baltimore-Washington Airport P.O. Box 1897 MS 984 Baltimore, MD 21203		Allied Amphenol Products Bendix Connector Operations 40-60 Delaware Street Sidney, NY 13838	77820	Augat, Inc. 33 Perry Avenue P.O. Box 799 Attleboro, MA 02703	91506
98003	Nielsen Hardware Corporation 770 Wethersfield Avenue P.O. Box 568 Hartford, CT 06141		Allied Devices Corporation 2365 Milburn Avenue P.O. Drawer E. Baldwin, NY 11510	29964	AVX Ceramics Division of AVX Corporation 19th Avenue South P.O. Box 867 Myrtle Beach, SC 29577	04222
98291	Sealectro Corporation BICC Electronics 40 Lindeman Drive Trumbull, CT 06611		Amerace Corporation Esna Division 2330 Vauxhall Road Union, NJ 07083	72962	Basler Electric Company RT 143 P.O. Box 269 Highland, IL 62249	97520
98410	ETC-Molex, Inc. Subsidiary of Molex, Inc. 5201 Richmond Road Bedford Heights, OH 44146		Amerace Corporation Buchanan Crimptool Products Division 1065 Floral Avenue Union, NJ 07083	83079	Beckman Instruments, Inc. Beckman Electronic Technologies Subsidiary of Smith Kline/Beckman Corporation 2500 Harbor Blvd. Fullerton, CA 92634	73138
98734	Hewlett-Packard Company Manufacturing Division Palo Alto, CA		American Trans-Coil Corporation 124-06 101st Avenue Richmond Hill, NY 11419	18212	Belden Corporation Subsidiary of Cooper Industries, Inc. 2000 S. Batavia Avenue Geneva, IL 60134	70903
99120	Plastic Capacitors, Inc. 2623 N. Pulaski Road Chicago, IL 60639		AMF, Inc. Potter and Brumfield Division 200 Richland Creek Drive Princeton, IN 47671	77342	Bell Industries, Inc. JW Miller Division 19070 Reyes Avenue P.O. Box 5825 Compton, CA 90224	96804
99167	Sundstrand Aviation Operations Unit of Sundstrand Corporation 4747 Harrison Avenue P.O. Box 7002 Rockford, IL 61125		AMF, Inc. Potter and Brumfield Division 200 Richland Creek Drive Princeton, IN 47671	89265	Bergquist Company, Inc., The 5300 Edina Industrial Blvd. Minneapolis, MN 55435	55285
			AMP, Inc. Capitron Division 1595 S. Mt. Joy Street Elizabethtown, PA 17022	89110		

**T.O. 31R2-2URC-83**

Bestran Corporation Dilectron Division 2669 So. Myrtle Avenue Monrovia, CA 91016	22701	Cardion Electronics Division of General Signal Controls, Inc. A Unit of General Signal Corporation Long Island Expressway Woodbury, NY 11797	12909	Department of Army U.S. Army Missile Command Redstone Arsenal, AL 35809	18876
Bethlehem Steel Corporation Shipbuilding Department Room 1000 Martin Tower Bethlehem, PA 18016	70983	Centralab, Inc. A North American Philips Company 4561 Colorado Los Angeles, CA 90039	16546	Designatronics, Inc. 55 S. Denton Avenue New Hyde Park, NY 11040	14519
Birtcher Corporation The Industrial Division 4501 N. Arden Drive P.O. Box 4399 El Monte, CA 91734	18915	Cera-Mite Corporation 1327 6th Avenue Grafton, WI 53024	60705	Designatronics, Inc. Stock Drive Products Division 55 S. Denton Avenue New Hyde Park, NY 11040	59076
Blinn Delbert Company, Inc. The 1678 E. Mission Blvd. P.O. Box 2007 Pomona, CA 91769 5065	08289	Cincinnati Electronics Corporation Subsidiary of GEC, Inc. An English Electric Corporation Company 2630 Glendale-Milford Road Cincinnati, OH 45241	80045	Dialight Division Ampere Electronic Corporation 203 Harrison Place Brooklyn, NY 11237	72619
Bourns, Inc. Trimpot Division 1200 Columbia Avenue Riverside, CA 92507	32997	Cornell-Dubilier Electronics 118 E. Jones Street Fuquay-Varina, NC 27526	09023	Dielectric Products Company, Inc. Jersey City, NJ	72634
Bourns, Inc. Precision/Controls Division 1200 Columbia Avenue Riverside, CA 92507	57921	Cornell-Dubilier Electronics Division of Federal Pacific Electric Company Government Contracts Department 150 Ave L Newark, NJ 07101	14655	Dixie Chemical Company 3635 W. Dallas Street Houston, TX 77019	15969
Bourns, Inc. Precision/Controls Division 1200 Columbia Avenue Riverside, CA 92507	57922	Corning Glass Works Houghton Park Corning, NY 14830	14674	Du Pont E I De Nemours and Company, Inc. Photo Products Department Berg Electronics Division Route 83 New Cumberland, PA 17070	22526
Bourns, Inc. Networks Division 12155 Magnolia Avenue Riverside, CA 92503	57924	Corning Glass Works 550 High Street Bradford, PA 16701	24546	Dzus Fastener Company, Inc. 425 Union Blvd. West Islip, NY 11795	72794
Bourns Instruments, Inc. 135 Magnolia Avenue Riverside, CA 92506	80294	Crouse-Hinds Arrow Hart Inc. Arrow Hart Division 103 Hawthorn Street Hartford, CT 06105	04009	Eaton Corporation AIL Division Lond Island Plants Commack Road Deer Park, L.I., NY 11729	00752
Breeze-Eastern Corporation Subsidiary of Transtechnology Corporation 700 Liberty Avenue Union, NJ 07083	08484	CSI Capacitors A Division of CSI Technologies, Inc. Del Dios Highway P.O. Box 2052 Escondido, CA 92025	10026	Eaton Corporation Engineered Fasteners Division 8700 Brookpark Road P.O. Box 6688 Cleveland, OH 44101	89032
Bunker Ramo-Eltra Corporation Amphenol Division 2801 S. 25th Avenue Broadview, IL 60153	02660	CTS Corporation 905 N. West Blvd. Elkhart, IN 46514	71450	Electro Motive Corporation Subsidiary of International Electronics Corporation Florence, SC	72136
Bussmann Division of McGraw-Edison Company 114 Old State Road P.O. Box 14460 St. Louis, MO 63178	71400	CTS Knights, Inc. 400 Reimann Avenue Sandwich, IL 60548	75378	Electronic Applications Company 4918 Santa Anita Avenue El Monte, CA 91734	21317
C and K Components, Inc. 15 Riverdale Avenue Newton, MA 02158	09353	CTS of Berne, Inc. 406 Parr Road Berne, IN 46711	11236	Electronic Laboratory Supply Company 7208 Germantown Avenue Philadelphia, PA 19119	28482
Cablewave Systems, Inc. 60 Dodge Avenue North Haven, CT 06473	16733	Curt Straub Enterprises 444 W. Ocean Blvd. Suite 1106 Long Beach, CA 90802	50173	Electronic Molding Corporation 96 Mill Street Woonsocket, RI 02895	17117
Caddock Electronics, Inc. 1717 Chicago Avenue Riverside, CA 92507	19647	Dataproducts New England, Inc. Barnes Park North Wallingford, CT 06492	96238	Eltra Corporation Subsidiary of Allied Chemical Company Medwec Division 105 Skyport Drive P.O. Box 417 Scottsbluff, NE 69361	54904
Carborundum Company The Electrical Products Division Global Plant 3425 Hyde Park Blvd. P.O. Box 339 Niagara Falls, NY 14302	72819	Defense Electronics Supply Center Dayton, OH 45401	14933	Emhart Industries, Inc. Hardware Division 225 Episcopal Road Berlin, CT 06037	70494
		Delavan Corporation 811 Fourth Street P.O. Box 100 West Des Moines, IA 50265	71895	Endicott Research Group, Inc. 2601 Wayne Street P.O. Box 269 Endicott, NY 13760	63312

E-T-A Circuit Breakers 7400 N. Croname Road Chicago, IL 60648	06402	Grayhill, Inc. 561 Hillgrove Avenue P.O. Box 10373 La Grange, IL 60525	81073	Illinois Tool Works, Inc. Paktron Division 900 Follin Lane S.E. Vienna, VA 22180	19396
ETC-Molex, Inc. Subsidiary of Molex, Inc. 5201 Richmond Road Bedford Heights, OH 44146	98410	Harrington And King Perforating Company, Inc., The 5655 Fillmore Street Chicago, IL 60644	73988	Incom International, Inc. Boston Gear Division, Inc. 14 Hayward Street Quincy, MA 02171	71041
Fairchild Camera and Instrument Corporation Semiconductor Division Subsidiary of Schlumberger LTD North American Sales Mail Stop 14-1053 401 Ellis Street P.O. Drawer 7284 Mountain View, CA 94042	07263	Harris Corporation RF Communications Division 1680 University Avenue Rochester, NY 14610	14304	Intel Corporation 3065 Bowers Avenue Santa Clara, CA 95051	34649
Fair-Rite Products Corporation 1 Commercial Row Wallkill, NY 12589	34899	Hartwell Corporation 900 S. Richfield Road Piacentia, CA 92670	83014	International Rectifier Semiconductor Division 233 Kansas Street El Segundo, CA 90245	59993
Federal Screw Products, Inc. 3917 N. Kedzie Avenue Chicago, IL 60618	73734	Hewlett-Packard Company Corporate HQ 3000 Hanover Street Palo Alto, CA 94304	28480	International Rectifier 9220 Sunset Blvd. Los Angeles, CA 90069	81483
Fenwal Electronics Division of Kidde Walter and Company, Inc. 63 Fountain Street Framingham, MA 01701	15801	Hewlett-Packard Company Optoelectronics Division 640 Page Hill Road Palo Alto, CA 94304	50434	Intersil Inc. Subsidiary of General Electric Company 10710 N. Tantau Avenue Cupertino, CA 95014	32293
Fox Electronics Fox Enterprises, Inc. P.O. Box 1078 Cape Coral, FL 33910	61429	Hewlett-Packard Company Manufacturing Division Palo Alto, CA	98734	ITT Cannon Electric Division of International Telephone and Telegraph Corporation 10550 Talbert Avenue P.O. Box 8040 Fountain Valley, CA 92708	71468
General Connector Corporation Subsidiary of the Union Corporation 80 Bridge Street Newton, MA 02158	25330	Heyco Molded Products 1750 Blvd. P.O. Box 160 Kenilworth, NJ 07033	28520	ITT Components Division International Telephone and Telegraph Corporation 3201 S. Standard Street P.O. Box 2197 Santa Ana, CA 92707	61725
General Electric Company Semi-Conductor Products Department W. Genesee Street Auburn, NY 13021	03508	High Energy Corporation Subsidiary of Inductotherm Corporation Lower Valley Road Parkesburg, PA 19365	21052	ITT Jennings 970 McLaughlin Avenue San Jose, CA 95116	73905
General Electric Company Aviation Service Operation/CINTI 333 W. Seymour Avenue Cincinnati, OH 45216	05326	HI-G Company Subsidiary of Nytronics Inc. 101 Locust Street Hartford, CT 06114	02289	ITT Telecom Products Corporation Network Systems Division HWY 137 Suncrest Drive P.O. Box N Carroll Reece Station Johnson City, TN 37601	21340
General Electric Company Power Components Operation W. Genesee Street Auburn, NY 13021	09214	Honeywell, Inc. Micro Switch Division 11 W. Spring Street Freeport, IL 61032	91929	JFD Electronic Components A Division of Murata Erie North America 112 Mott Street Oceanside, NY 11572	73899
General Electric Company 3135 Easton Turnpike Fairfield, CT 06431	24446	Hughes Electronic Devices Corporation 13321 Grass Valley Avenue P.O. Box 185 Grass Valley, CA 95945	61587	Johnson EF Company 299 10th Avenue SW Waseca, MN 56093	74970
General Electronics, Inc. Paterson, NJ	80101	Hutchens Industries, Inc. 215 N. Patterson Avenue P.O. Box 1427 SSS Springfield, MO 65805	92967	Keystone Carbon Company 1935 State Street St. Marys, PA 15857	75263
General Instrument Corporation Government Systems Division 600 W. John Street Hicksville, NY 11802	05828	IDI Electric Canada LTD 33 Fuller Road Box 159 Ajax, Ontario Canada L1S 2E1	51144	Kings Electronics Company, Inc. 40 Marbledale Road Tuckahoe, NY 10707	91836
General Instrument Corporation Lamp Division/Worldwide 4433 N. Ravenswood Avenue Chicago, IL 60640	74276	Illinois Capacitor, Inc. 3757 W. Touhy Avenue Lincolnwood, IL 60645	74840	Kulka Electric Corporation A North American Philips Corporation Mt. Vernon, NY	75382
Gochenaur Marine Company Philadelphia, PA	72835	Illinois Tool Works, Inc. Fastex Division 195 Algonquin Road Des Plaines, IL 60016	02768	Kulka Smith, Inc. A North American Philips Company 1913 Atlantic Avenue Manasquan, NJ 08736	83330

**T.O. 31R2-2URC-83**

Lapointe Industries, Inc. Electronic Products Division 155 W. Main Street Rockville, CT 06066	94033	McDonnell Douglas Corporation McDonnell Aircraft Company P.O. Box 516 St. Louis, MO 63166	76301	Minnesota Mining and Manufacturing Company Electro Products Division 341 Factory Road Addison, IL 60101	52760
Lee Spring Company, Inc. 1462 62nd Street Brooklyn, NY 11219	84830	Mepco/Electra, Inc. A North American Philips Company P.O. Box 760 Mineral Wells, TX 76067	19701	Minnesota Mining and Manufacturing Company Data Recording Products Division 350 S. Lewis Road Camarillo, CA 93010	54254
Leeds and Northrup Company A Unit of General Signal Corporation Sumneytown Pike North Wales, PA 19454	31922	Mepco/Electra, Inc. 6071 St. Andrews Road Columbia, CS 29210	56699	Minor Rubber Company, Inc. 49 Ackerman Street Bloomfield, NJ 07003	76385
Library Efficiency Corporation New York, NY	81249	Mepco/Electra, Inc. 22 Columbia Road Morristown, NJ 07960	80031	Mite Corporation Amatom Electronic Hardware Division 446 Blake Street New Haven, CT 06515	06540
Licon Division of Illinois Tool Works, Inc. 6615 W. Irving Park Road Chicago, IL 60634	04426	Metraplex Corporation Berkshire Industrial Park Bldg. 3 Bethel, CT 06801	52559	Mite Corporation 466 Blake Street New Haven, CT 06515	26344
Litton Industries, Inc. Litton Systems Inc. Triad-Utrad Division 305 N. Briant Street Huntington, IN 46750	04386	Midland-Ross Corporation Cambion Division Barnstead Road Pittsfield, NH 03263	53373	Molex, Inc. 2222 Wellington Court Lisle, IL 60532	27264
Litton Industries, Inc. Triad Distributor Division Huntington, IN	26667	Midland-Ross Corporation Cambion Division One Alewife Place Cambridge, MA 02140	71279	Moto Meter Gauge and Equipment Division Electric Auto Lite Company New York, NY	76490
Luminescent Systems Inc. Etna Road Grafton County Lebanon, NH 03756	32890	Micro Plastics, Inc. HWY 178 N. Flippin, AR 72634	13764	Motorola, Inc. Semiconductor Products Sector 5005 E. McDowell Road Phoenix, AZ 85008	04713
LXD 24500 High Point Road Cleveland, Ohio 44122	66670	Microtran Co., Inc. 145 E. Mineola Avenue P.O. Box 236 Valley Stream, NY 11582	00348	Murata Erie North America, Inc. Erie Operations 645 W. 11th Street Erie, PA 16512	72982
Magna Division Vermont American Corporation 1001 West Park Road Elizabethtown, KY 42701	11195	Midwest Components, Inc. 1981 Port City Blvd. P.O. Box 787 Muskegon, MI 49443	50157	Murato Erie Technological Products State College Operations 1900 W. College Avenue State College, PA 16801	18796
Magnavox Government and Industrial Electronics Co. 1313 Production Road Fort Wayne, IN 46808	37695	Mil Spec	81349	National Semiconductor Corporation Commerce Drive P.O. Box 443 Danbury, CT 06810	12040
Magnecraft Electric Company 5575 N. Lynch Avenue Chicago, IL 60630	94696	Mil Spec	96906	National Semiconductor Corporation 2900 Semiconductor Drive Santa Clara, CA 95051	27014
Magnum Electric Corporation 6385 Dixie HWY Erie, MI 48133	52458	Millen Division Electronic Instrument and Specialty Corporation 42 Pleasant Street Stoneham, MA 02180	57285	NEC America, Inc. 2741 Prosperity Avenue Fairfax, VA 22031	51984
Marine Corps. Navy Annex Washington, DC 20380	80372	Mini-Circuits Laboratory Division of Scientific Components Corporation 2625 E. 14th Street Brooklyn, NY 11235	15542	Neilsen Products Company Lake Elmo, MN	00758
Marson Corp. 130 Crescent Avenue Chelsea, MA 02150	10054	Minnesota Mining and Manufacturing Company Industrial Tape Division 3M Center St Paul, MN 55101	26066	Nielsen Hardware Corporation 770 Wethersfield Avenue P.O. Box 568 Hartford, CT 06141	98003
Masstech Corporation Subsidiary of Transtechnology Corporation Swamp Road RT 313 P.O. Box 2001 Doylestown, PA 18901	94464	Minnesota Mining and Manufacturing Company Industrial Coated Abrasives Division 3M Center St. Paul, MN 55101	28124	Niagara Straw Company, Inc. 72 Lakeview Avenue Buffalo, NY 14201	60963
Matsushita Electric Corporation of America One Panasonic Way P.O. Box 1501 Secaucus, NJ 07094	54473	Minnesota Mining and Manufacturing Company Energy Systems 3M Center Bldg. 551 St. Paul, MN 55101	30142	Nytronics Components Group, Inc. Subsidiary of Nytronics Inc. Orange Street Darlington, SC 29532	00213

Ohmite Manufacturing Company 3601 W. Howard Street Skokie, IL 60076	44655	RCA Corporation Solid State Division Crestwood Road Mountaintop, PA 18707	18722	Signetics Corporation Military Products Division 4130 S. Market Court Sacramento, CA 95834	18324
Ordnance Corps The Defense Logistics Services Center	00000	RCA Corporation 30 Rockefeller Plaza New York, NY 10020	49671	Siliconix, Inc. 2201 Laurelwood Road Santa Clara, CA 95054	17856
Palco Connector, Inc. 75 Center Street Bristol, CT 06010	58167	RCA Corporation RCA Service Company RTE 38 Cherry Hill, NJ 08358	77609	Silvered Electronic Mica Company, Inc. RT 6 Willimantic, CT 06226	61306
Panduit Corporation 17301 Ridgeland Tinley Park, IL 60477	06383	RCD Components, Inc. 330 Bedford Street Manchester, NH 03101	56637	Singer Company The Link Flight Simulation Division Advanced Products Operation 1077 E. Arques Avenue P.O. Box 3484 Sunnyvale, CA 94088	22903
PCC Pertec Division Pertec Computer Corporation 9600 Irondale Avenue Chatsworth, CA 91311	32097	Republic Electronics Corporation 176 E. 7th Street Paterson, NJ 07524	93958	SNC Manufacturing Company, Inc. 101 Waukau Road Oshkosh, WI 54901	83325
PEM Engineering Company Los Angeles, CA	99256	Rockwell International Corporation Collins Telecommunications Products Division Defense Electronics Operations 855 NE 35th Street Cedar Rapids, IA 52498	13499	Southco, Inc. 210 N. Brinton Lake Road Concordville, PA 19331	94222
Penn Engineering and Manufacturing Corporation Old Easton Road P.O. Box 1000 Danboro, PA 18916	46384	Rogan Corporation 3455 Woodhead Drive Northbrook, IL 60062	86797	Spectrol Electronics Corporation Subsidiary of Carrier Corporation 17070 E. Gale Avenue P.O. Box 1220 City of Industry, CA 91749	02111
Phoenix Specialty Manufacturing Company, Inc. 971 Stewart Avenue Garden City, LI, NY 11530	77264	Rotron Controls Division Rotron, Inc. Woodstock, NY	32284	Sprague Electric Company 87 Marshall Street North Adams, MA 01247	56289
PIC Design Corporation Division of Wells-Benrus Corporation Benson Road P.O. Box 1004 Middlebury, CT 06762	00141	Rotron, Inc. Custom Division 7 Hasbrouck Lane Woodstock, NY 12498	82877	Stackpole Corporation, The 201 Stackpole Street St. Marys, PA 15857	78488
Plastic Capacitors, Inc. 2623 N. Pulaski Road Chicago, IL 60639	99120	Samtec, Inc. 810 Progress Blvd. P.O. Box 1147 New Albany, IN 47150	55322	Stimpson Company, Inc. 900 Sylvan Avenue Bayport, NY 11705	57771
Plastiglide Manufacturing Corporation 2701 W. El Segundo Blvd. Hawthorne, CA 90250	11897	Sanders Associates, Inc. Daniel Webster HWY South Nashua, NH 03061	94117	Stone City Products, Inc. 1206 7th Street P.O. Box 369 Bedford, IN 47421	09166
Poulsen and Wardon, Inc. Los Angeles, CA	77347	Sangamo Weston, Inc. Sangamo Capacitor Division Subsidiary of Schlumberger LTD Sangamo Road P.O. Box 128 Pickens, SC 29671	00853	Sundstrand Aviation Operations Unit of Sundstrand Corporation 4747 Harrison Avenue P.O. Box 7002 Rockford, IL 61125	99167
Power Conversion, Inc. 495 Boulevard Elmwood Park, NJ 07407	55002	Sargent Art Division of Mead Corporation Hazleton, PA	00493	Switchcraft, Inc. Subsidiary of Raytheon Company 5555 N. Elstron Avenue Chicago, IL 60630	82389
Pulse Engineering, Inc. 5004 Lehigh Road College Park, MD 20740	61735	Seaelectro Corporation BICC Electronics 40 Lindeman Drive Trumbull, CT 06611	98291	T and B/Ansley Corporation Subsidiary of Thomas and Betts Corporation 4371 Valley Blvd. Los Angeles, CA 90031	15912
Pyrofilm Division Division of KDI Electronics Inc. 60 S. Jefferson Road Whippany, NJ 07981	03888	Seastrom Manufacturing Company, Inc. 701 Sonora Avenue Glendale, CA 91201	86928	Tektronix, Inc. 4900 SW Griffith Drive P.O. Box 500 Beaverton, OR 97077	80009
Quam Nichols Company 218 E. Marquette Road Chicago, IL 60637	74199	Shielding Technology, Inc. Subsidiary of Chomerics, Inc. 120 Ethel Road W. Piscataway, NJ 08854	59950	Texas Instruments Inc. Semiconductor Group 13500 N. Central Expressway P.O. Box 225012 M/S 49 Dallas, TX 75265	01295
R A F Electronic Hardware, Inc. 95 Silvermine Road Seymour, CT 06483	55566	Signal Transformer Company, Inc. 500 Bayview Avenue Inwood, NY 11696	08779		

**T.O. 31R2-2URC-83**

Texas Instruments, Inc. Equipment Group 13500 N. Central EXPY P.O. Box 660246 M/S 3137 Dallas, TX 75266	96214	USM Corporation Subsidiary of Emhart Industries, Inc. USM Fastener Division 510 River Road Shelton, CT 06484	07707	Zierick Manufacturing Company Radio Circle Mt. Kisco, NY 10549	81814
Thermalloy Company, Inc. 2021 W. Valley View Lane P.O. Box 340839 Dallas, TX 75234	13103	USM Corporation Subsidiary of Emhart Industries, Inc. 140 Federal Street Boston, MA 02107	61957		
Thomas and Betts Corporation HWY 218 S. Iowa City, IA 52240	59730	Vaco Products Company 1510 Skokie Blvd. Northbrook, IL 60062	79061		
Thompson Industries Division of W M F Container Corporation 2501 E. Magnolia Street Phoenix, AZ 85036	32848	Varian Associates, Inc. Pulse Engineering Subsidiary 7250 Convoy CT P.O. Box 12235 San Diego, CA 92112	01961		
Toshiba Internation Industrial Division 13131 W. Little York Road P.O. Box 40906 Houston, TX 77041	61802	Varian Associates, Inc. ELMAC Division 301 Industrial Way San Carlos, CA 94070	06980		
Tracor Littelfuse, Inc. 800 E. Northwest HWY Des Plaines, IL 60016	75915	Varian Associates, Inc. Microwave Tube Division 611 Hansen Way Palo Alto, CA 94303	99313		
Triad Transformer Corporation Huntington, IN	16741	Varo, Inc. Electron Devices Division 2203 Walnut Street P.O. Box 401146 Garland, TX 75040	27777		
Triad-Utrad Division Litton Systems, Inc. National City, CA	81095	Varo Semiconductor, Inc. Subsidiary of Varo, Inc. 1000 N. Shiloh Road P.O. Box 40676 Garland, TX 75040	62703		
TRW, Inc. TRW Cinch Connectors Division 1501 Morse Avenue Elk Grove Village, IL 60007	71785	Veeco Instruments, Inc. Lambda Electronics Division 515 Broad Hollow Road Melville, NY 11747	80103		
TRW, Inc. TRW Electronic Components IRC Fixed Resistors Philadelphia Division 401 N. Broad Street Philadelphia, PA 19108	75042	Vitramon, Inc. Box 544 Bridgeport, CT 06601	95275		
Union Carbide Corporation Electronics Division HWY 276 SE P.O. Box 5928 Greenville, SC 29606	31433	Wakefield Engineering Company P.O. Box 818 Coeur D Alene, ID 83814	90372		
Uniroyal, Inc. Oxford Management and Research Center Benson Road Middlebury, CT 06749	61463	Waldes Kohinoor, Inc. 47-16 Austel Place Long Island City, NY 11101	79136		
United Shoe Machinery Corporation Cincinnati, OH	08544	Waterous Company 300 John E. Carroll Avenue E. South St. Paul, MN 55075	79218		
Unitrode Corporation 580 Pleasant Street Watertown, MA 02172	12969	Westinghouse Electric Corporation Defense and Electronic Systems Center Baltimore-Washington Airport P.O. Box 1897 MS 984 Baltimore, MD 21203	97942		
U.S. Army Armament Research and Development Command Dover, NJ 07801	19200	WH Brady Company 727 W. Glendale Avenue Milwaukee, WI 53209	95987		
U.S. Army Communications and Electronics Materiel Readiness Command Logistics Engineering Directorate Fort Monmouth, NJ 07703	80063	Zeus Industrial Products, Inc. Ft. Thompson Street Raritan, NJ 08869	32039		
U.S. Army Tank Automotive Command Warren, MI 48090	19207	Zierick Manufacturing Company Radio Circle Mt. Kisco, NY 10549	79963		



**JOINT MILITARY SERVICES UNIFORM SMR CODING MATRIX T.O. 00-25-195**

SOURCE		MAINTENANCE USE		REPAIR		RECOVERABILITY		ERRC CODE									
1st Position		2nd Position		3rd Position		4th Position		5th Position		6th Position							
P	Procurable	A	Stocked	O	Remove/ Replace at Organizational Level	Z	No Repair	Z	Nonreparable Condemn at 3rd Position Level	N	Nonrecoverable XB3 Condemn at Any Level						
		B	Insurance														
		C	Deteriorative														
		E	Support Equipment, Stocked														
		F	Support Equipment, Nonstocked														
		G	Sustained Life Support														
K	Component of a Repair Kit	F	Intermediate Kit	F	Remove/ Replace at Inter- mediate Level	O	Repair at Organizational	F	Reparable Condemn at Intermediate	C	Recoverable XD1 (SCARS) Condemn at Depot						
		D	Depot Kit														
		B	In Both Kits														
M	Manufacture	O	Organization							D	Remove/Replace at Depot Level	D	Limited Repair at O or F Level	D	Reparable Condemn at Depot	S	Nonexpendable Support Equipment, Depot ND2
		F	Intermediate														
		D	Depot														
A	Assemble	O	Organization	L	Repair at Depot	A	Special Handling	U	Nonexpendable Support Equipment, Organizational and Intermediate NF2								
		F	Intermediate														
		D	Depot														
X	Nonprocured	A	Requisition NHA														
		B	Reclamation from IM														
		C	Mfg Drawings														

SECTION II. MAINTENANCE PARTS LIST

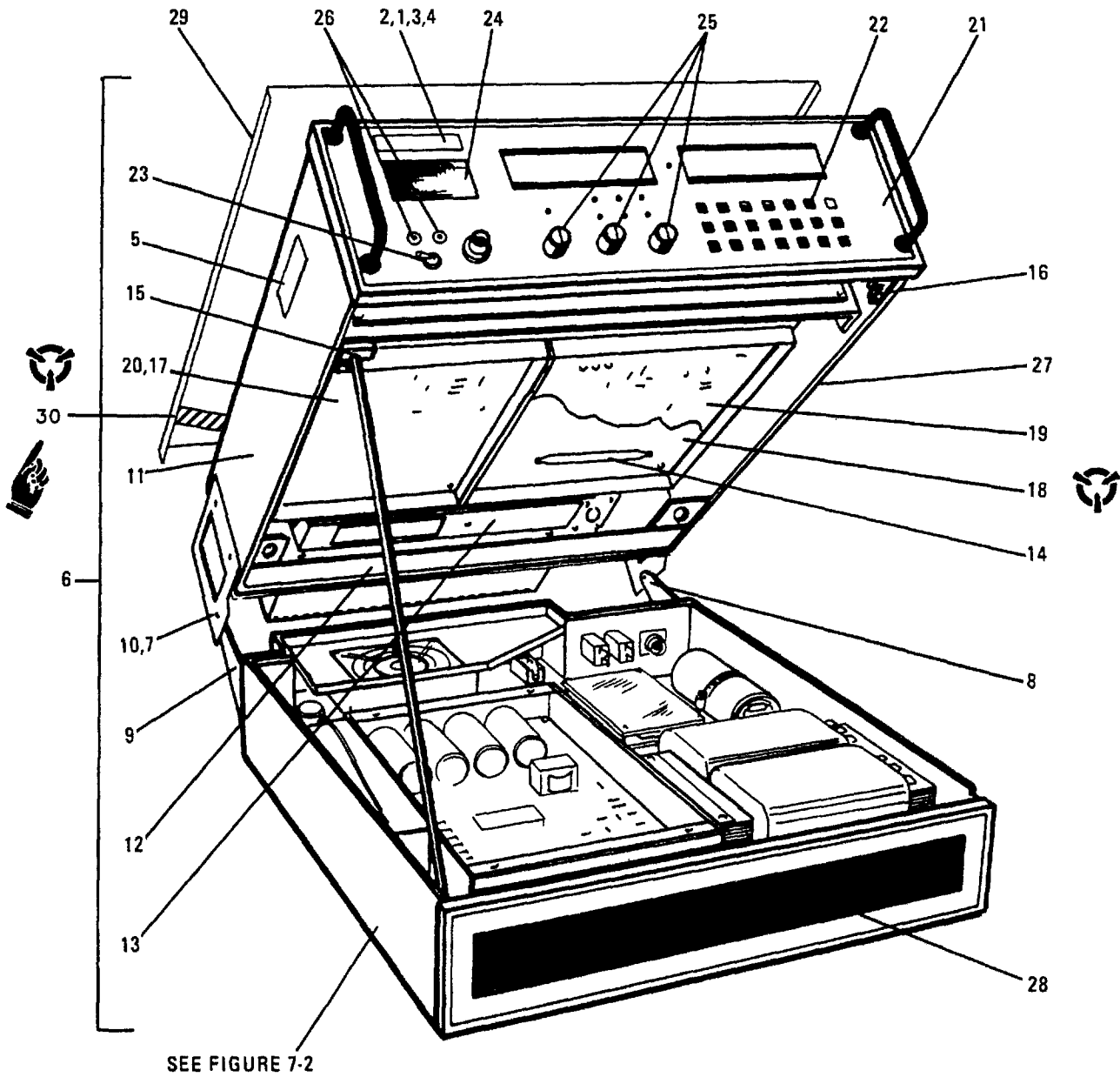

F9504416

Figure 7-1. 100 Watt Transceiver, RT-1446/URC, Front View

FIGURE & INDEX NUMBER	PART NUMBER	CAGE	DESCRIPTION							UNITS PER ASSY	USABLE ON CODE	SMR CODE
			1	2	3	4	5	6	7			
7-1-	10085-0000	14304	RCVR-XMTR, RADIO* .....							1		PEODD
- 1	841-00	92967	. NUT, CLINCH (AP) .....							2		PAOZZ
- 2	10085-0008	14304	. PLATE, IDENT .....							1		XB
- 3	MS15795-803	96906	. WASHER, FLAT (AP).....							2		PAOZZ
- 4	MS51957-18	96906	. SCREW, MACHINE (AP).....							2		PAOZZ
- 5	10085-0071	14304	. PLATE, IDENT .....							1		MDO
- 6	10085-0010	14304	. TRANSCIVER ASSY .....							1		XB
- 7	MS16633-1025	96906	. RETAINER, RING .....							2		PAOZZ
- 8	10085-0522	14304	. BRACKET, HINGE.....							1		XB
- 9	10085-0523	14304	. BRACKET, HINGE.....							1		XB
-10	10085-0524	14304	. PIN HINGE .....							2		XB
-11	10085-0100	14304	. CHASSIS, ELEC, EQPT .....							1		XB
-12	10085-0528	14304	. BRACKET, PANEL .....							1		XB
-13	10085-0529	14304	. CHASSIS, PA .....							1		XB
-14	10085-0530	14304	. HANDLE, COVER.....							10		XB
-15	10085-5143	14304	. BRACKET, MTG .....							1		XB
-16	10085-5159	14304	. HINGE .....							2		XB
-17	10085-5174	14304	. COVER, RCVR.....							1		XB
-18	10085-5175	14304	. COVER, EXCITER .....							1		XB
-19	10085-5400	14304	. CIRCUIT CARD ASSY, A1A1.....							1		PAODD
-20	10085-5200	14304	. CIRCUIT CARD ASSY, A1A7.....							1		PAOLD
-21	10085-2017	14304	. OVERLAY, PANEL .....							1		XB
-22	10085-2007	14304	. KEYPAD.....							1		PAOZZ
-23	7401T1ZGE	09353	. SWITCH, TOGGLE.....							1		PAOZZ
-24	22-SLOTB-BRASS	73988	. SHIELD, SPEAKER .....							1		XB
-25	MS-67-1-DC-WD	86797	. KNOB .....							3		PAOZZ
-26	66332-7	00779	. CONTACT ELECTRICAL.....							2		PAOZZ
-27	10085-5139	14304	. COVER GUIDE.....							2		PADZZ
-28	10085-0271	14304	. FILTER, AIR .....							1		PAOZZ
-29	10085-0105	14304	. COVER TOP .....							1		XB
-30	31-0064040	07700	. SHIELDING GASKET ELECTRONIC.....							1		PAOZZ

\*Installation requires Ancillary Kit 10085-0060. See figure 7-9.

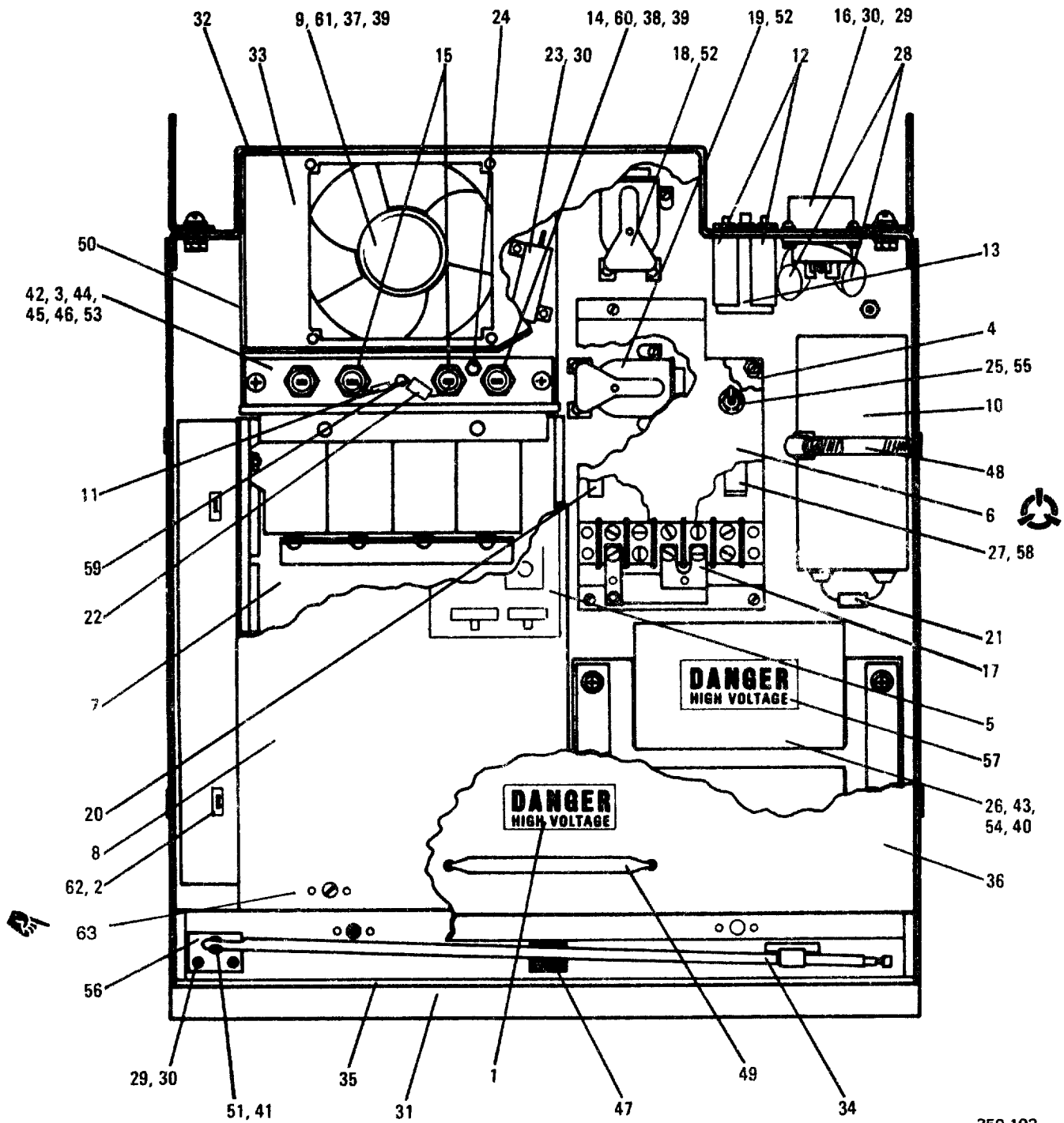

Figure 7-2. 100 Watt Transceiver, RT-1446/URC, Bottom Half

FIGURE & INDEX NUMBER	PART NUMBER	CAGE	DESCRIPTION							UNITS PER ASSY	USABLE ON CODE	SMR CODE
			1	2	3	4	5	6	7			
7-2	10085-0200	14304	COVER ASSY, A2 .....							1		PAODD
- 1	10085-0079	14304	. LABEL WARNING .....							1		PAODD
- 2	MS3367-4-9	96906	. STRAP, TIE DOWN .....							30		PADZZ
- 3	7403-09FR-21	55285	. INSULATOR WASHER .....							1		PADZZ
- 4	10085-0250	14304	. BRACKET, MTG .....							1		XB
- 5	10085-5129	14304	. LABEL, TERM BLK .....							1		MDO
- 6	10085-0290	14304	. CIRCUIT CARD ASSY, A2A1 .....							1		PAODD
- 7	10085-0260	14304	. POWER SUPPLY ASSY, A2A2 .....							1		PAODD
- 8	10085-0263	14304	. COVER .....							1		XB
- 9	028868	82877	. FAN .....							1		PAOZZ
-10	3120GH663U050AP	19701	. CAP, FX, ELCTLT .....							1		PADZZ
-11	CK06BX104K	81349	. CAPACITOR, FXD, CER .....							1		PADZZ
-12	W58XB1A6A-6	77342	. CIRCUIT BREAKER .....							2		PAOZZ
-13	41-3-S14-LN2-50	06402	. CIRCUIT BREAKER .....							1		PAOZZ
-14	70HFR20	81483	. SEMICOND DEVICE, DIO .....							2		PADZZ
-15	70HF20	81483	. SEMICOND DEVICE, DIO .....							2		PADZZ
-16	MS3102A20-8P	96906	. CONNECTOR, RCPT, ELEC .....							1		PADZZ
-17	10085-0204	14304	. CONTACT, ELEC .....							1		XB
-18	W199SDX-2	94696	. RELAY .....							1		PADZZ
-19	W199SDX-3	94696	. RELAY .....							1		PADZZ
-20	389CX-7	94696	. RELAY .....							1		PADZZ
-21	RCR42G102JS	81349	. RESISTOR, FXD, COMP .....							1		PADZZ
-22	RCR32T100JS	81349	. RESISTOR, FXD, COMP .....							1		PADZZ
-23	RER25F1R00R	81349	. RESISTOR, FXD, WW (P/N) .....							1		PAOZZ
			RER75F1R00R, CAGE 81349)									
-24	10085-0254	14304	. RESISTOR, THERMAL .....							1		PADZZ
-25	82617	07858	. SWITCH .....							1		PADZZ
-26	10085-0213	14304	. TRANSFORMER, RF .....							1		PADZZ
-27	241-5-2151	08779	. TRANSFORMER, POWER .....							1		PADZZ
-28	V275LA40A	09214	. VARISTOR .....							2		PADZZ
-29	MS15795-803	96906	. WASHER, FLAT (AP) .....							10		PADZZ
-30	MS51957-16	96906	. SCREW, MACHINE (AP) .....							8		PADZZ
-31	10085-0270	14304	. PANEL .....							1		XB
-32	10085-0205	14304	. CHASSIS .....							1		XB
-33	10085-0262	14034	. BRACKET, MTG .....							1		XB
-34	10085-0257	14304	. BRACE .....							1		XB
-35	10085-0264	14304	. FRAME, FILTER .....							1		XB
-36	10085-0249	14304	. COVER .....							1		XB
-37	MS51957-38	96906	. SCREW, MACHINE (AP) .....							4		PAOZZ
-38	MS35338-136	96906	. WASHER, SPLIT (AP) .....							6		PADZZ
-39	MS15795-805	96906	. WASHER, FLAT (AP) .....							11		PADZZ
-40	MS15795-808	96906	. WASHER, FLAT (AP) .....							6		PADZZ
-41	MS15795-807	96906	. WASHER, FLAT (AP) .....							3		PADZZ
-42	10085-0252	14304	. HEATSING .....							1		XB
-43	10085-0278	14304	. BRACKET, MTG .....							2		XB
-44	B25600F002	04713	. INSULATOR .....							2		XB
-45	B51568F029	04713	. NUT, PLAIN, HEX (AP) .....							2		PAOZZ
-46	B15547F013	04713	. BUSHING .....							2		XB
-47	1575	28124	. BUMPER, RUBBER .....							1		XB
-48	OS200M36	08484	. CLAMP, HOSE .....							1		XB
-49	10029-0073	14304	. HANDLE .....							1		PAOZZ
-50	ZX-4464 30DUREO	76385	. GASKET .....							22		XB

T.O. 31R2-2URC-83

Figure & Index Number	Part Number	FSCM	Description 1 2 3 4 5 6 7	Units Per Assy	Usable On Code	SMR Code
-51	4318	00141	. SCREW, MACHINE (AP)	1		PAOZZ
-52	MS24693-C26	96906	. SCREW, MACHINE (AP)	6		PAOZZ
-53	MS51957-45	96906	. SCREW, MACHINE (AP)	2		PAOZZ
-54	MS51958-72	96906	. SCREW, MACHINE (AP)	4		PAOZZ
-55	20590-174AS	04009	. RING, SWITCH	1		XB
-56	10085-0273	14304	. BRACKET, ANGLE	1		XB
-57	MP-0745	14304	. LABLE	1		XB
-58	H-6768	14304	. NUT, CLINCH (AP)	12		XB
-59	4858-1-0516	71279	. SPACER	1		XB
-60	MS51957	96906	. SCREW, MACHINE (AP)	4		PAOZZ
-61	476042	82877	. PROTECTOR, FAN	1		XB
-62	TC-105A	59730	. BASE	8		XB
-63	F4-30-SS	72794	. SCREW, CAPTIVE	2		PAZZN



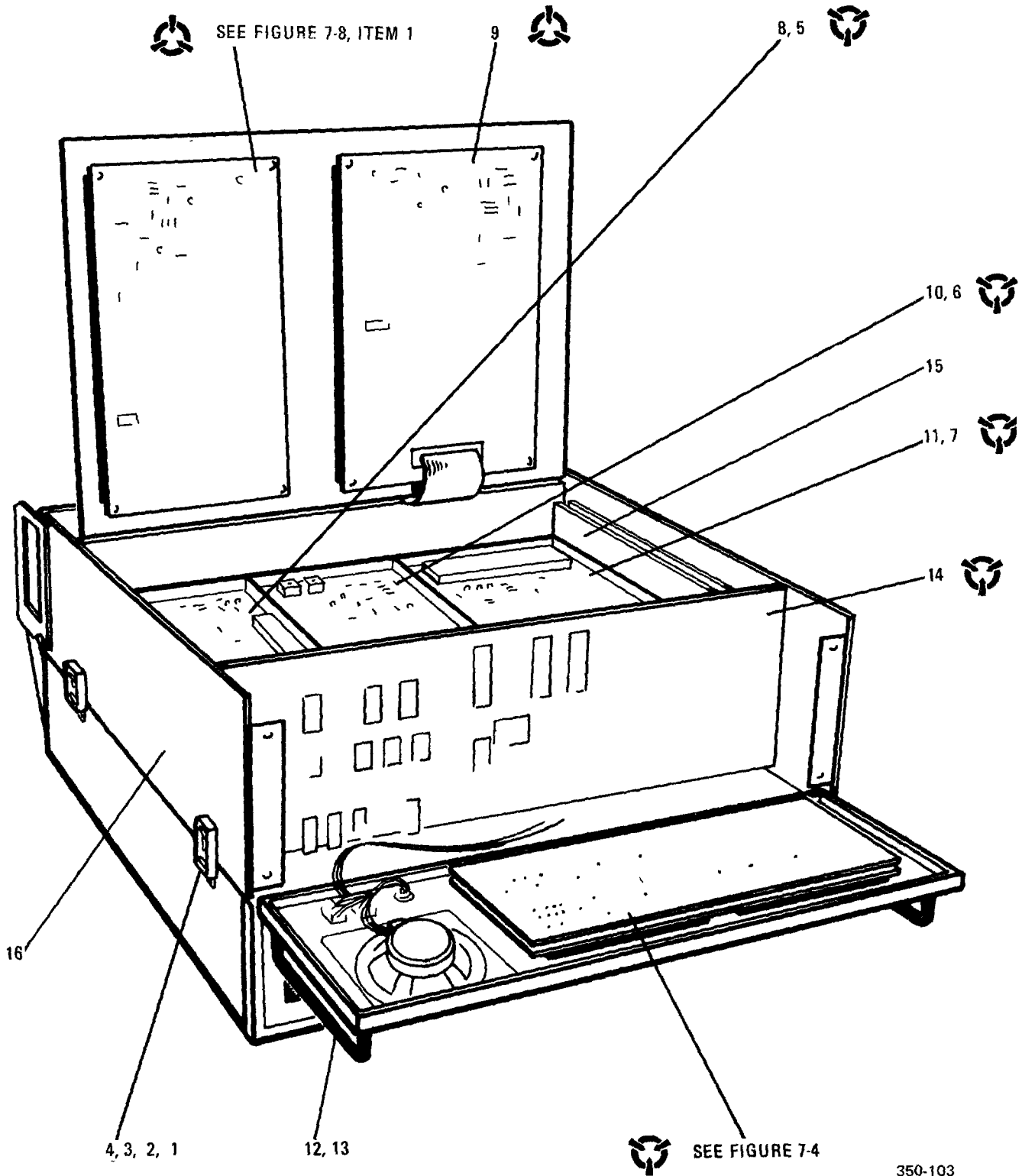

350-103

Figure 7-3. 100 Watt Transceiver, RT-1446/URC, Internal Components

(7-19 Blank)/7-20



Figure & Index Number	Part Number	FSCM	Description							Units Per Assy	Usable On Code	SMR Code
			1	2	3	4	5	6	7			
7-3 - 1	10085-0535	14304								4		PAOZZ
- 2	MS35338-134	96906								8		PAOZZ
- 3	MS51957-4	96906								8		PAOZZ
- 4	H408-1	83014								4		PAOZZ
- 5	10085-5171	14304								1		XB
- 6	10085-5172	14304								1		XB
- 7	10085-5173	14304								1		XB
- 8	10085-5000	14304								1		PAODD
- 9	10085-5250	14304								1		PAODD
- 10	10085-5500	14304								1		PAODD
- 11	10085-5600	14304								1		PAODD
- 12	10350-A-1032-2	06540								2		XB
- 13	MS24693-C272	96906								4		PAOZZ
- 14	10085-9000	14304								1		PAODD
- 15	10085-0516	14304								1		XB
- 16	10085-0500	14304								1		XB

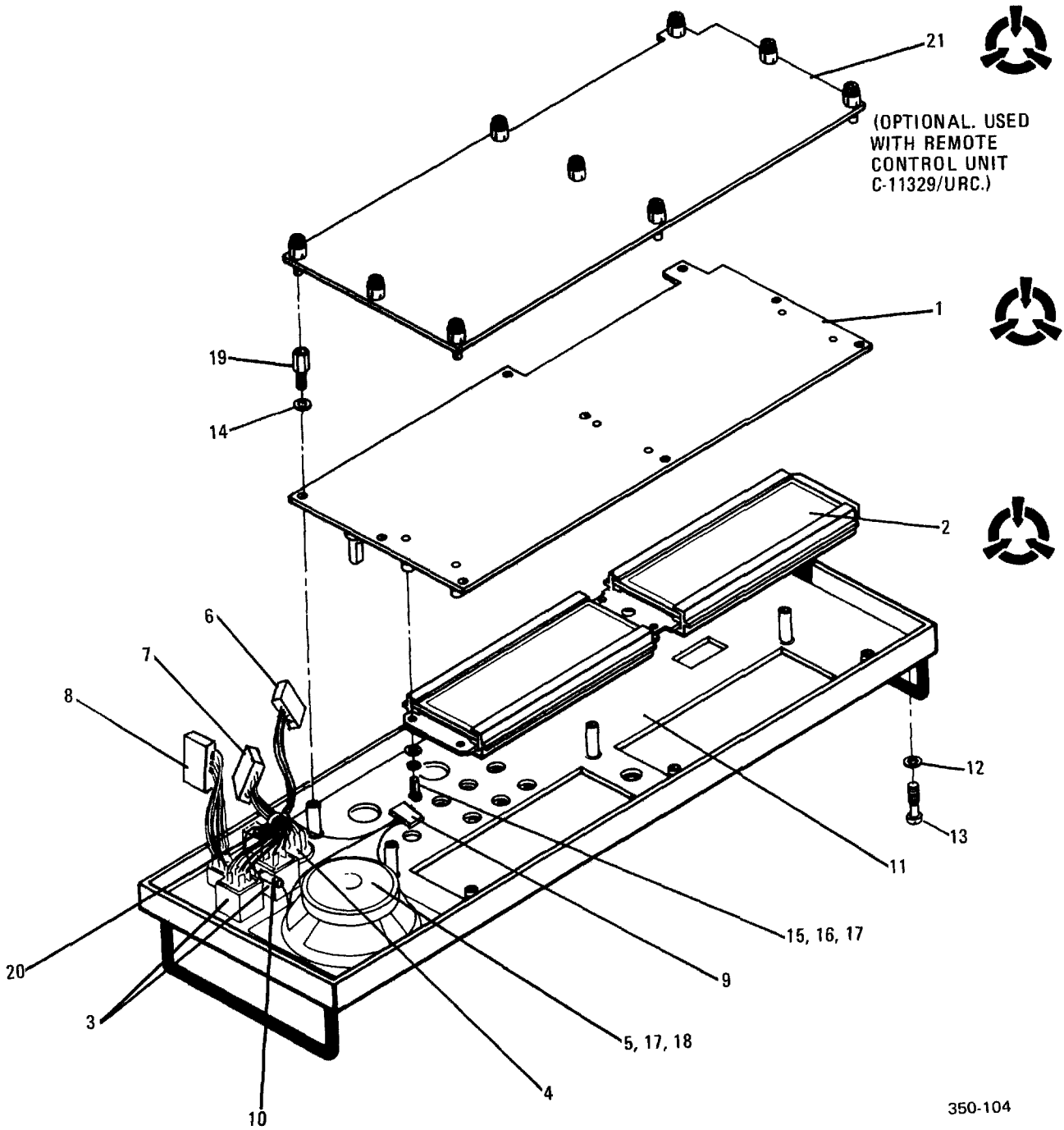
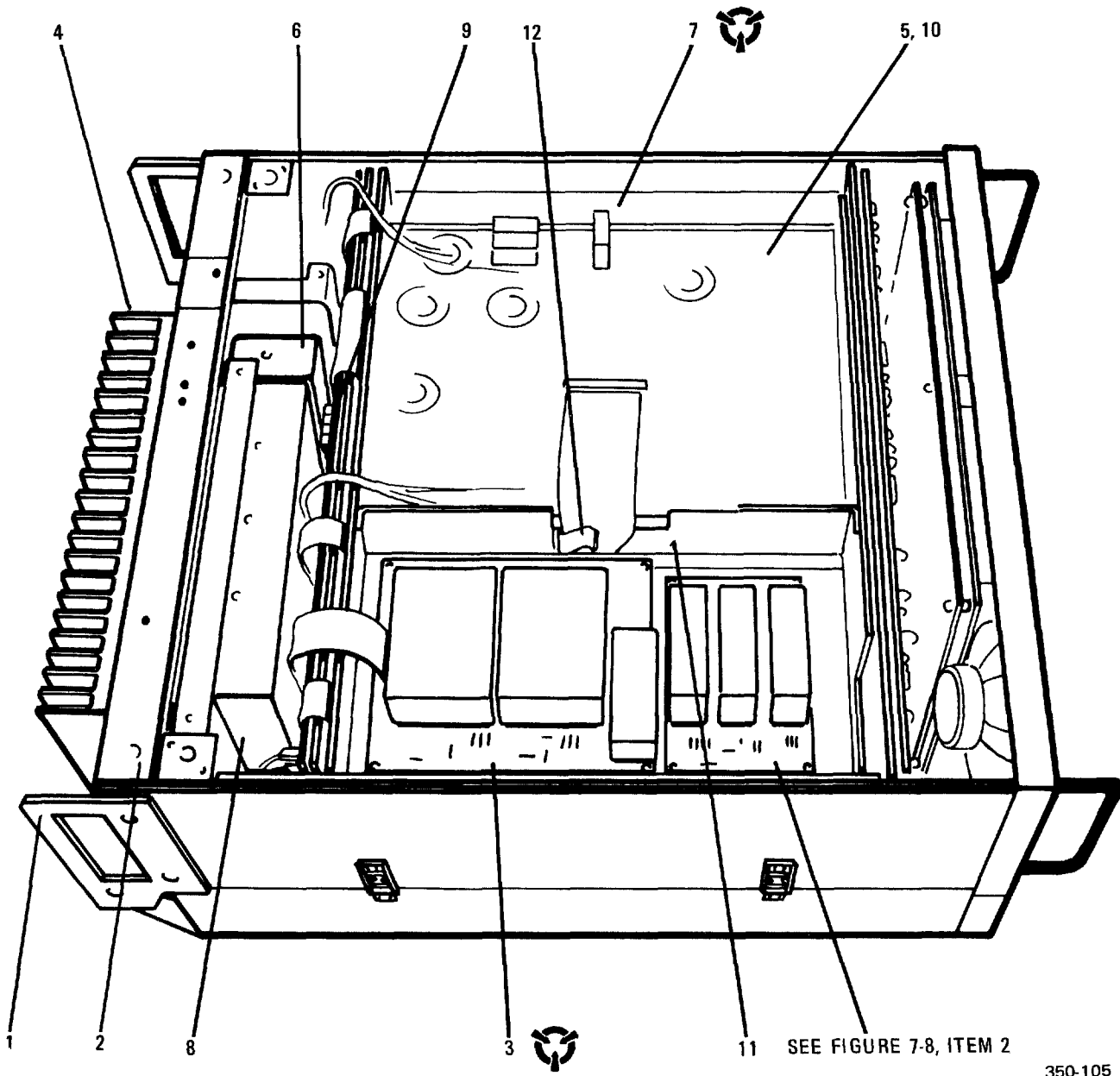

Figure 7-4. 100 Watt Transceiver, RT-1446/URC, Front Panel Assy, A1A11

Figure & Index Number	Part Number	FSCM	Description							Units Per Assy	Usable On Code	SMR Code
			1	2	3	4	5	6	7			
7-4 -	10085-2000	14304	PANEL ASSY,A1A11							1		PAODD
- 1	10085-2100	14304	. CIRCUIT CARD ASSY, A1A11A1							1		PAODD
- 2	10085-2110	14304	. DISPLAY ASSY,A1A11A2							1		PAODD
- 3	113	82389	. CONNECTOR,RCPT,ELEC							2		PADZZ
- 4	GC283	25330	. CONNECTOR,RCPT,ELEC							1		PADZZ
- 5	82-8666	74199	. SPEAKER							1		PAOZZ
- 6	22-01-3057	27264	. CONNECTOR,PLUG,ELEC							1		PADZZ
- 7	22-01-3087	27264	. CONNECTOR,PLUG,ELEC							1		PADZZ
- 8	207376-1	00779	. CONNECTOR,PLUG,ELEC							1		PADZZ
- 9	22-01-3037	27264	. CONNECTOR,PLUG,ELEC							1		PADZZ
- 10	RN55D4751F	81349	. RESISTOR,FXD,FILM							1		PADZZ
- 11	10085-2019	14304	. PANEL							1		XB
- 12	10087-2011	14304	. WASHER,FLAT (AP)							4		PAOZZ
- 13	10087-2012	14304	. SCREW,MACHINE (AP)							4		PAOZZ
- 14	MS35333-70	96906	. WASHER,LOCK (AP)							9		PADZZ
- 15	MS51957-14	96906	. SCREW,MACHINE (AP)							7		PADZZ
- 16	MS35338-135	96906	. WASHER,SPLIT (AP)							7		PADZZ
- 17	MS15795-803	96906	. WASHER,FLAT (AP)							6		PADZZ
- 18	H-6768	14304	. NUT,CLINCH (AP)							4		XB
- 19	9725-SS-0440-7	06540	. POST ELEC MECH							9		PAOZZ
- 20	TC-105A	59730	. BASE							1		XB
- 21	10088-6000	14304	CIRCUIT CARD ASSY,A1A19							1		PAODD



350-105

Figure 7-5. 100 Watt Transceiver, RT-1446/URC, Top Side View

Figure & Index Number	Part Number	FSCM	Description 1 2 3 4 5 6 7	Units	Usable	SMR Code
				Per Assy	On Code	
7-5 - 1	10085-5157	14304	BRACKET, HINGE	2		XB
- 2	10085-0527	14304	BRACKET, PANEL	1		XB
- 3	10085-5300	14304	CIRCUIT CARD ASSY, A1A2	1		PAODD
- 4	10085-8010	14304	100W PA, 12V, ASSY, A1A4	1		PAODD
- 5	10085-4000	14304	CIRCUIT CARD ASSY, A1A5	1		PAOLD
- 6	10085-0610	14304	OSCILATOR ASSY, RF, A1A8	1		PAOZZ
- 7	10085-7000	14304	CIRCUIT CARD ASSY, A1A13	1		PAODD
- 8	10085-1240	14304	MULTIVOLT SPLY ASSY, A1A14	1		PAODD
- 9	10085-4210	14304	CIRCUIT CARD ASSY, A1A15	1		PADLD
- 10	10085-5106	14304	COVER	1		XB
- 11	10085-0510	14304	BRACKET	1		XB
- 12	3484-1000	30142	CLIP SPRING TENSION	2		PADZZ

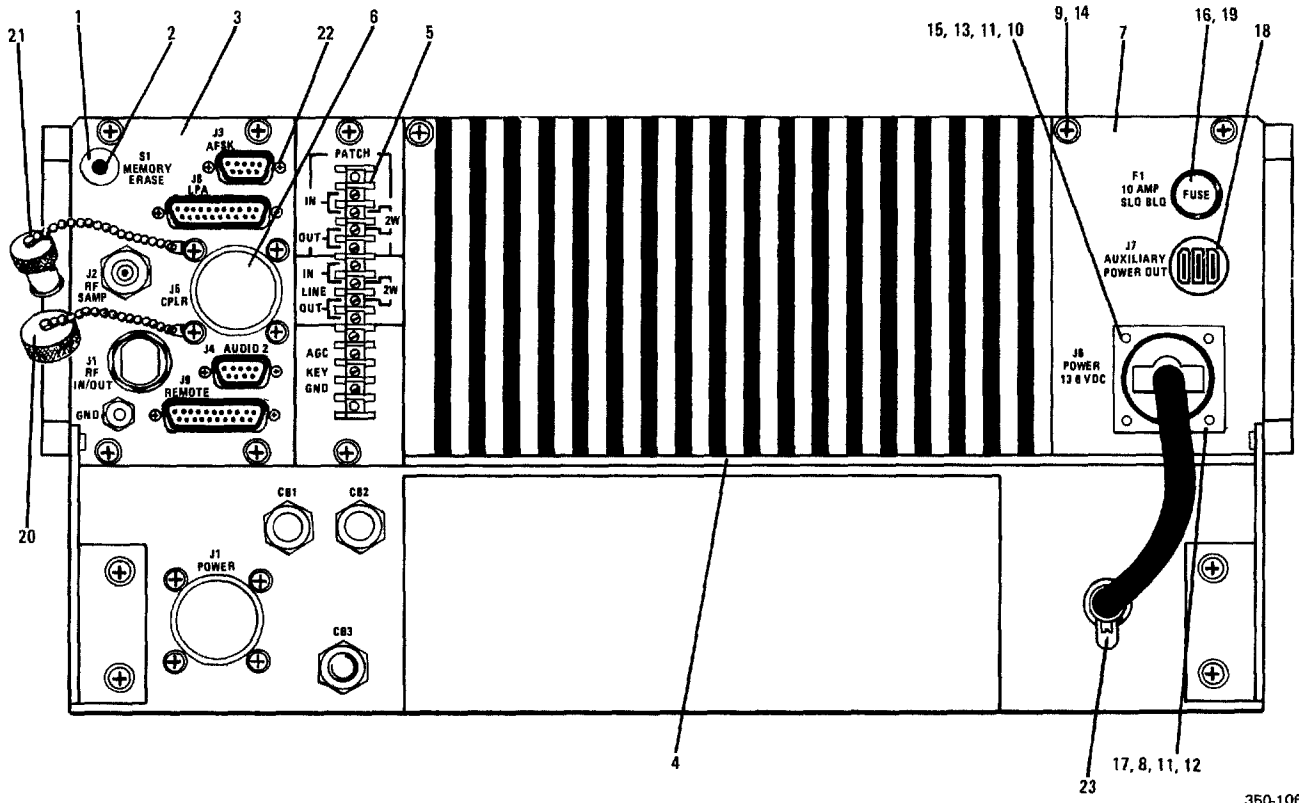

350-106

Figure 7-6. 100 Watt Transceiver, RT-1446/URC, Rear View

Figure & Index Number	Part Number	FSCM	Description							Units Per Assy	Usable On Code	SMR Code
			1	2	3	4	5	6	7			
7-6 - 1	G-12-A	95146								1		PAOZZ
- 2	3101-1261	28482								1		PAOZZ
- 3	10085-0525	14304								1		XB
- 4	10085-0526	14304								1		XB
- 5	10085-0570	14304								1		PAODD
- 6	10085-0550	14304								1		PAOLD
- 7	10085-0580	14304								1		PAODD
- 8	10085-0521	14304								1		XB
- 9	10085-5131	14304								4		PADZZ
- 10	H-6769	14304								4		XB
- 11	MS15795-803	96906								5		PADZZ
- 12	905-23	75915								1		PADZZ
- 13	MS35338-135	96906								3		PADZZ
- 14	MS35338-136	96906								4		PADZZ
- 15	MS51957-16	96906								4		PADZZ
- 16	F02B32V10A	81349								1		PAOZZ
- 17	MS3102R20-8P	96906								1		PADZZ
- 18	4525	04009								1		PADZZ
- 19	HKP-HH	71400								1		PADZZ
- 20	M39012/25-0011	81349								1		PADZZ
- 21	M39012/25-0006	81349								1		PADZZ
- 22	205817-1	00779								2		PADZZ
- 23	1730-BLACK	28520								1		XB

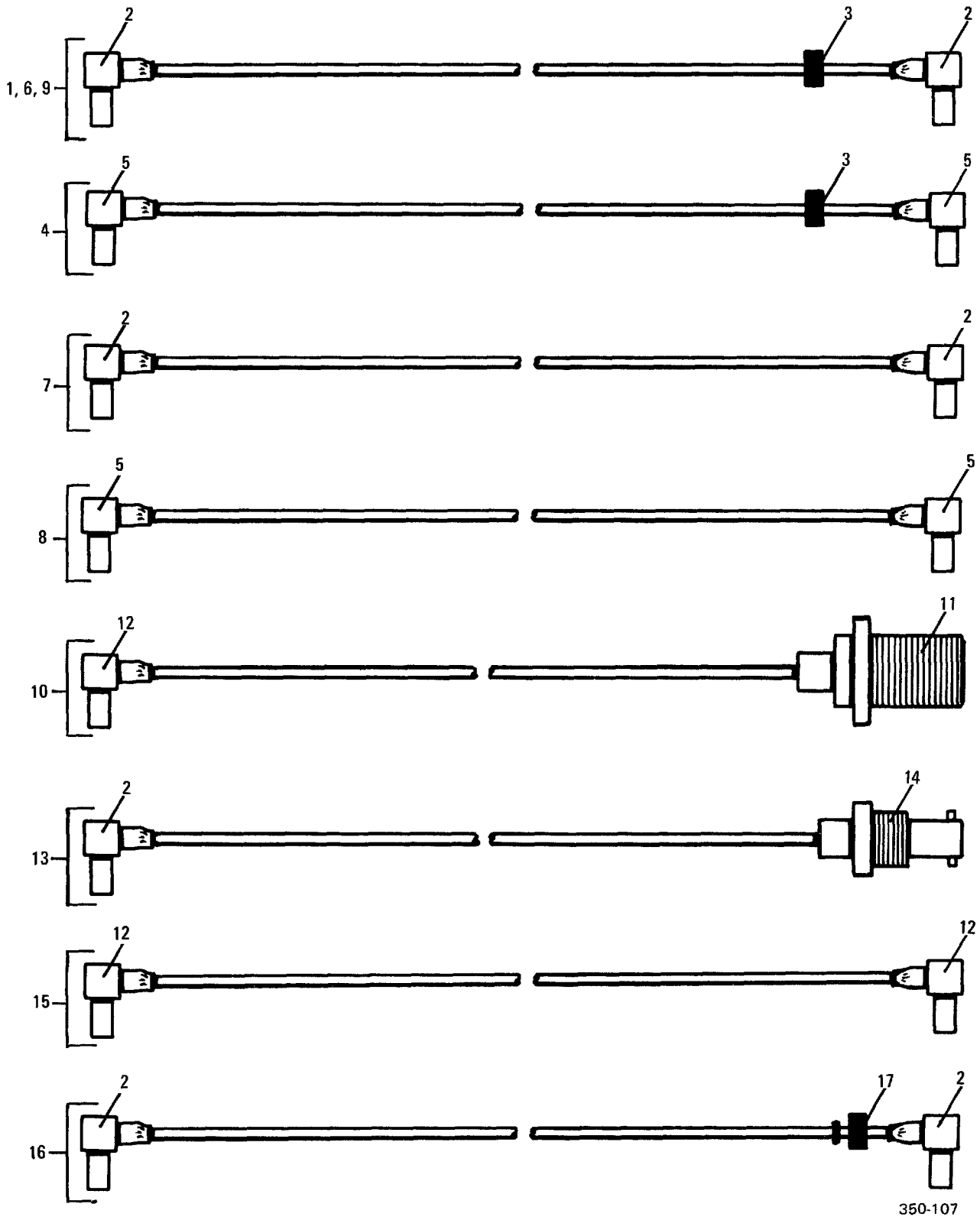
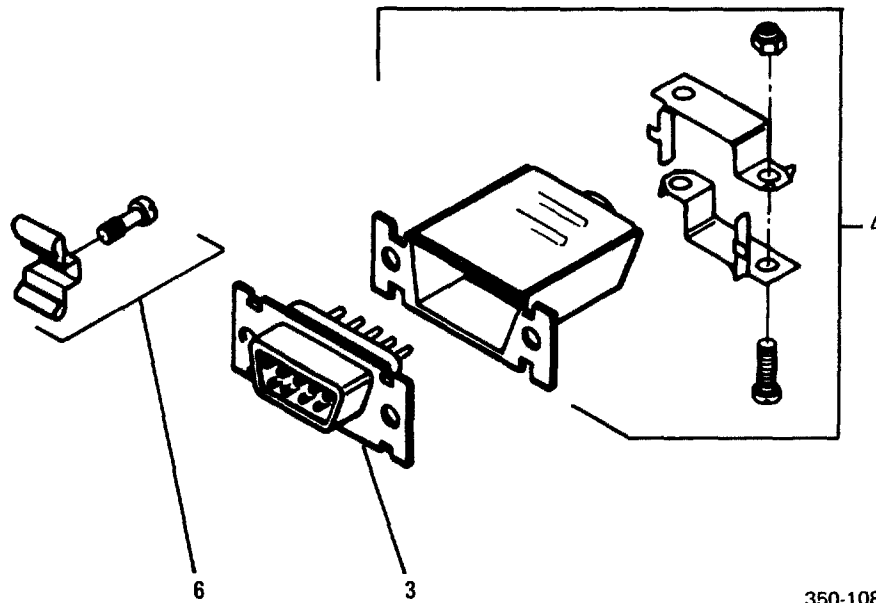
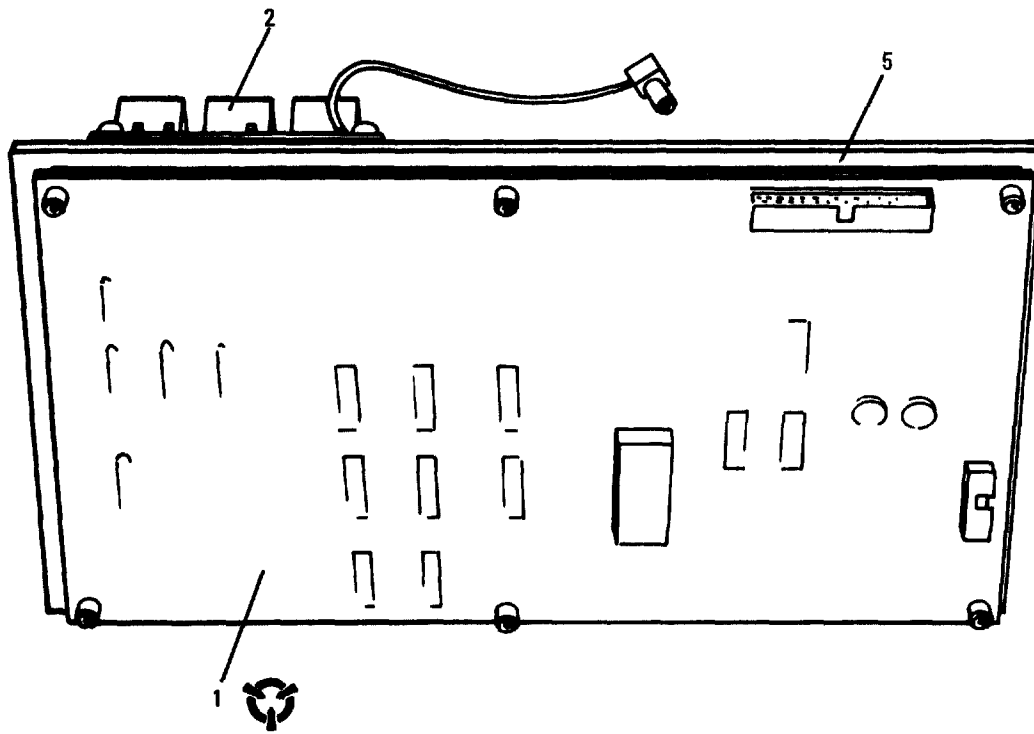

Figure 7-7. Coaxial Cables



Figure & Index Number	Part Number	FSCM	Description							Units Per Assy	Usable On Code	SMR Code
			1	2	3	4	5	6	7			
7-7 - 1	10085-0300-01	14304								1		PAOZZ
- 2	51-328-3850-916	92891								2		XA
- 3	MS35489-4	96906								1		XA
- 4	10085-0300-02	14304								1		PAOZZ
- 5	51-328-3188-2291	98291								2		XA
- 6	10085-0300-03	14304								1		PAOZZ
- 7	10085-0300-04	14304								1		PAOZZ
- 8	10085-0300-05	14304								1		PAOZZ
- 9	10085-0300-06	14304								1		PAOZZ
- 10	10085-0300-07	14304								1		PAOZZ
- 11	50-1510-0671S	58167								1		XA
- 12	51-328-3875-220	98291								1		XA
- 13	10085-0300-08	14304								1		PAOZZ
- 14	225398-8	00779								1		XA
- 15	10085-0300-09	14304								1		PAOZZ
- 16	10085-0300-13	14304								1		PAOZZ
- 17	11-220-B									1		XA



350-108

Figure 7-8. Module Assy, AFSK, A1A18 (Optional)

Figure & Index Number	Part Number	FSCM	Description							Units Per Assy	Usable On Code	SMR Code
			1	2	3	4	5	6	7			
7-8 -	10085-6000	14304	MODULE ASSY AFSK,A1A18							1		PAODD
- 1	10085-6100	14304	. KY/CONV,AFSK ASSY, A1A18A1							1		PADDD
- 2	10085-6200	14304	. 1F/FLTR,AFSK ASSY, A1A18A2							1		PADDD
- 3	M24308/3-1	81349	. CONNECTOR,RCPT,ELEC							1		PADZZ
- 4	DE24657	71468	. HOOD,CONNECTOR							1		PADZZ
- 5	10085-5144	14304	. BRACKET,MTG							1		XB
- 6	D20419-16	71468	. RETAINER CONN							1		XB

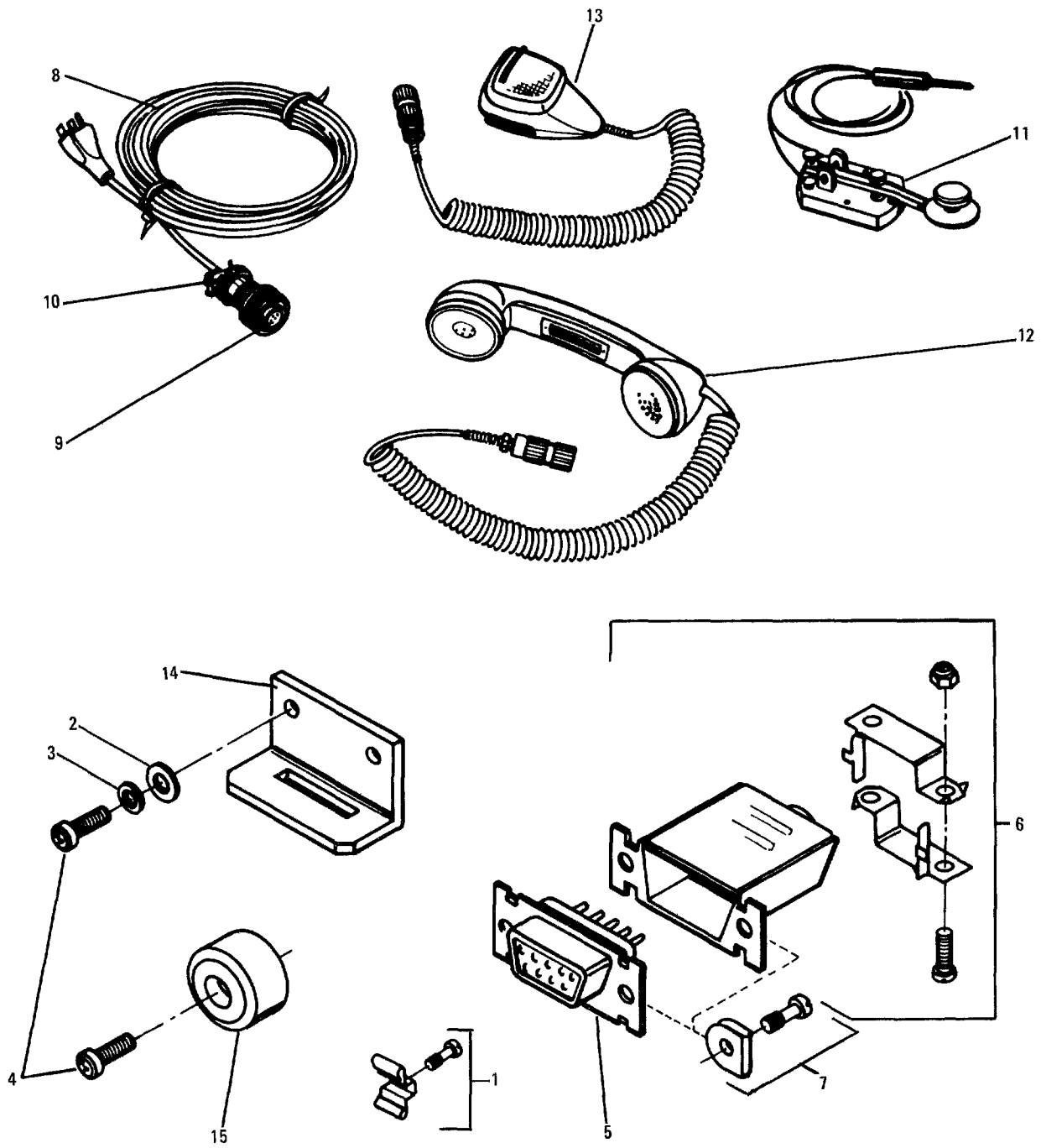

350-109

Figure 7-9. Installation Kit for the 100 Watt Transceiver

Figure & Index Number	Part Number	FSCM	Description 1 2 3 4 5 6 7	Units	Usable	SMR Code
				Per Assy	On Code	
7-9 -	10085-0060	14304	INSTALLATION KIT	1		XB
- 1	D20419-16588D205-12	94033	. FASTENER, SCREW-LOCK	2		PAOZZ
- 2	MS15795-805	96906	. WASHER, FLAT (AP)	8		PAOZZ
- 3	MS35338-136	96906	. WASHER, SPLIT (AP)	8		PAOZZ
- 4	MS51957-28	96906	. SCREW, MACHINE (AP)	12		PAOZZ
- 5	M24308/1-1	81349	. CONNECTOR, RCPT, ELEC	1		PAOZZ
- 6	DE24657	71468	. SHIELD ELECTRICAL	1		PAOZZ
- 7	588D205-12	94033	. SCREW, RETAINING	2		PAOZZ
- 8	10085-0065	14304	. CABLE ASSY	1		XB
- 9	MS3106A20-8SC	96906	. CONNECTOR, RCPT, ELEC	1		PAOZZ
- 10	M85049/41-12A	81349	. CLAMP, CABLE	1		PAOZZ
- 11	10085-0066	14304	. CW KEY ASSY	1		XB
- 12	10085-0067	14304	. HANDSET	1		XB
- 13	10085-0068	14304	. MICROPHONE	1		PAOZZ
- 14	10087-3106	14304	. BRACKET	4		XB
- 15	827S	70485	. BUMPER, RUBBER	4		PAOZZ

Figure & Index Number	Connects to:					
7-10-	1	FRONT PANEL ASSY (A1A11) - XCVR CONTROL PWB ASSY (A1A12) - EXCITER PWB ASSY (A1A1)				
-	2	EXCITER PWB ASSY (A1A1) - SYNTHESIZER PWB ASSY (A1A10) - RECEIVER PWB ASSY (A1A8) - LPA COUPLER INTERFACE PWB ASSY (A1A13) - XCVR CONTROL PWB ASSY (A1A12) - INTERCONNECT PWB ASSY (A1A15)				
-	3	AUD 2 CONNECTOR - AUDIO INTERFACE PWB ASSY (A1A16) - EXCITER PWB ASSY (A1A1) - INTERCONNECT PWB ASSY (A1A15)				
-	4	REMOTE CONTROL CONNECTOR - REMOTE CONTROL INTERFACE PWB ASSY (A1A19) - AUDIO INTERFACE PWB ASSY (A1A16)				
-	5	INTERCONNECT PWB ASSY (A1A15) - AFSK KEYER/CONVERTER PWB ASSY (A1A18A1)				
-	6	AFSK CONNECTOR - AFSK KEYER/CONVERTER PWB ASSY (A1A18A1)				

Figure & Index Number	Part Number	FSCM	Description 1 2 3 4 5 6 7	Units	Usable	SMR Code
				Per Assy	On Code	
7-10-	1	10085-0322	CABLE ASSY, RF, A1W10	1		PADZZ
-	2	10085-0324	CABLE ASSY, RF, A1W11	1		PADZZ
-	3	10085-0346	CABLE ASSY, RF, A1W12	1		PADZZ
-	4	10088-6007	CABLE ASSY, RF, A1W13	1		PADZZ
-	5	10085-0329	CABLE ASSY, RF, A1W14	1		PADZZ
-	6	10085-0330	CABLE ASSY, RF, A1W15	1		PADZZ

Figure 7-10. Non-Pendant Cable List

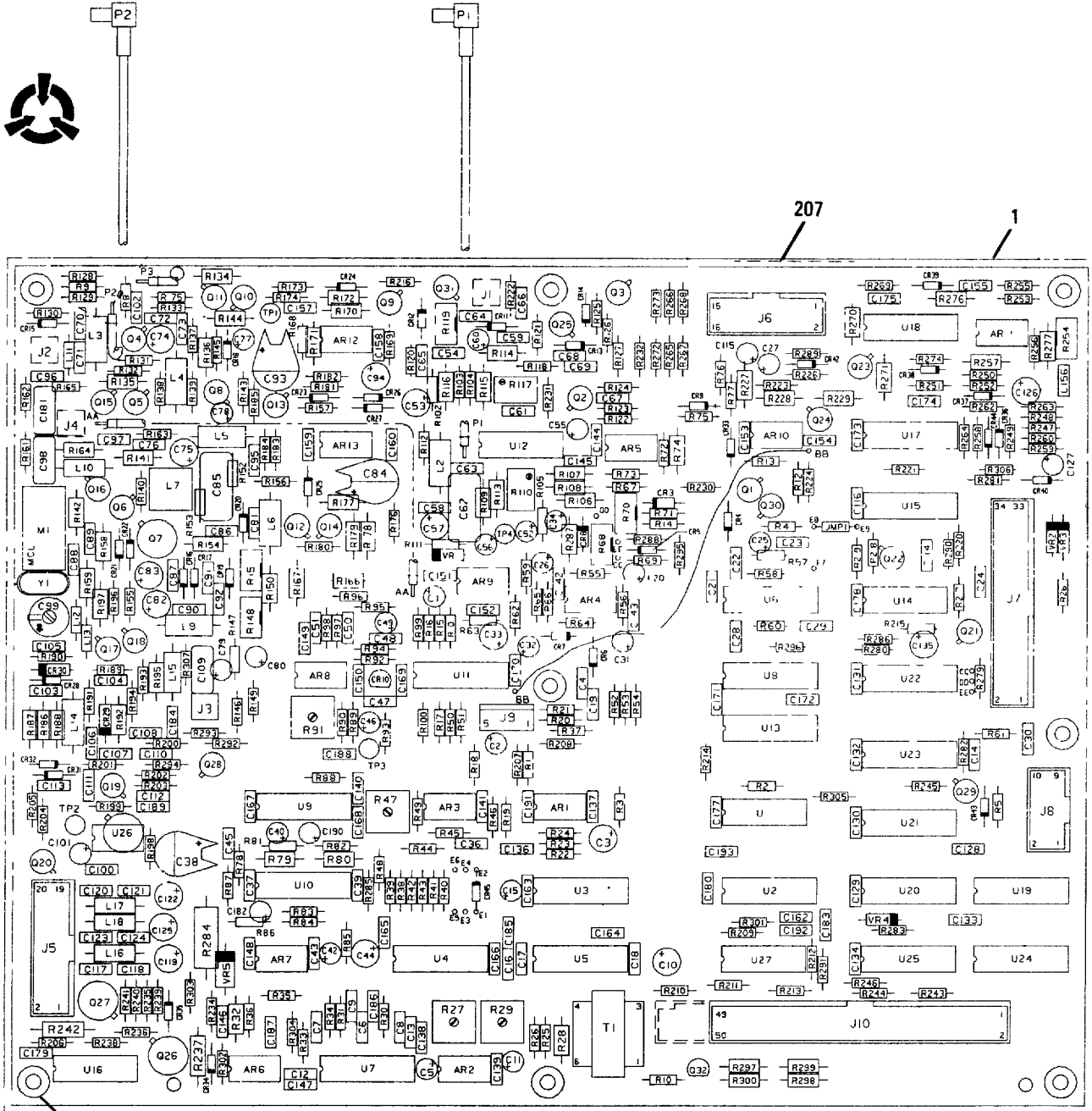

208, 209, 210, 211, 212

350-110

Figure 7-11. Exciter PWB Assy, A1A1

## NOTE

To find index numbers for circuit board components, use the reference designator index at the end of this chapter. The complete reference designator for a circuit board component consists of "1," followed by the assembly designator (A1A1, A1A2, etc.), then the reference designator on the illustration. For example, the complete reference designator for R25 on the Exciter PWB Assy is 1A1A1 R25.

Figure & Index Number	Part Number	FSCM	Description							Units Per Assy	Usable On Code	SMR Code
			1	2	3	4	5	6	7			
7-11-	10085-5400	14304	CIRCUIT CARD ASSY,A1A1							1		PAODD
- 1	10085-5165	14304	. COVER							1		XB
- 2	TL071MJG	01295	. MICROCIRCUIT							2		PADZZ
- 3	MC1558U	04713	. MICROCIRCUIT							11		PADZZ
- 4	T392B335K025AS	31433	. CAP,FXD,ELCTLT							19		PADZZ
- 5	T392C106M025AS	31433	. CAP,FXD,ELCTLT							14		PADZZ
- 6	M39014102-1338	81349	. CAPACITOR,FXD,CER							13		PADZZ
- 7	T392B335M025AS	31433	. CAP,FXD,ELCTLT							19		PADZZ
- 8	M39014/02-1350	81349	. CAPACITOR,FXD,CER							80		PADZZ
- 9	M39014/02-1356	81349	. CAPACITOR,FXD,CER							5		PADZZ
- 10	M39014/01-1345	81349	. CAPACITOR,FXD,CER							5		PADZZ
- 11	M39014/02-1360	81349	. CAPACITOR,FXD,CER							16		PADZZ
- 12	CK06BX224K	81349	. CAPACITOR,FXD,CER							5		PADZZ
- 13	CK05BX221K	81349	. CAPACITOR,FXD,CER							5		PADZZ
- 14	CK06BX474K	81349	. CAPACITOR,FXD,CER							16		PADZZ
- 15	CK06BX104K	81349	. CAPACITOR,FXD,CER							79		PADZZ
- 16	T392B155K035AS	31433	. CAP,FXD,ELCTLT							4		PADZZ
- 17	T392B155M035AS	31433	. CAP,FXD,ELCTLT							4		PADZZ
- 18	T392F686M025AS	31433	. CAP,FXD,ELCTLT							2		PADZZ
- 19	M39014/01-1330	81349	. CAPACITOR,FXD,CER							1		PADZZ
- 20	M39014/01-1342	81349	. CAPACITOR,FXD,CER							2		PADZZ
- 21	CK05BX151K	81349	. CAPACITOR,FXD,CER							2		PADZZ
- 22	CK06BX103K	81349	. CAPACITOR,FXD,CER							14		PADZZ
- 23	M39014/02-1343	81349	. CAPACITOR,FXD,CER							1		PADZZ
- 24	CMR06F102GODR	81349	. CAPACITOR,FXD,MICA							2		PADZZ
- 25	M39014/02-1345	81349	. CAPACITOR,FXD,CER							1		PADZZ
- 26	T392D226K025AS	31433	. CAP,FXD,ELCTLT							2		PADZZ
- 27	T392D226M025AS	31433	. CAP,FXD,ELCTLT							2		PADZZ
- 28	CM06FD102J03	81349	. CAPACITOR,FXD,MICA							2		PADZZ
- 29	M39014/01-1357	81349	. CAPACITOR,FXD,CER							3		PADZZ
- 30	M39014/01-1339	81349	. CAPACITOR,FXD,CER							1		PADZZ
- 31	CK05BX102K	81349	. CAPACITOR,FXD,CER							3		PADZZ
- 32	M39014/01-1351	81349	. CAPACITOR,FXD,CER							1		PADZZ
- 33	T392C475K025AS	31433	. CAP,FXD,ELCTLT							1		PADZZ
- 34	CMR05E330GODR	81349	. CAPACITOR,FXD,MICA							2		PADZZ
- 35	DV11PS15D	73899	. CAPACITOR,VARIABLE							1		PADZZ
- 36	CM05ED330J03	81349	. CAPACITOR,FXD,MICA							2		PADZZ
- 37	T392B106K010AS	31433	. CAP,FXD,ELCTLT							2		PADZZ
- 38	T392B106M010AS	31433	. CAP,FXD,ELCTLT							2		PADZZ
- 39	CMR05E200JODR	81349	. CAPACITOR,FXD,MICA							1		PADZZ
- 40	JAN1N3611	81349	. SEMICOND DEVICE,DIO							2		PADZZ
- 41	JAN1N4454	81349	. SEMICOND DEVICE,DIO							25		PADZZ
- 42	MSD6150	04713	. SEMICOND DEVICE,DIO							1		PADZZ
- 43	353-3733-010	13499	. SEMICOND DEVICE,DIO							6		PADZZ
- 44	5082-3168	98734	. SEMICOND DEVICE,DIO							6		PADZZ

Figure & Index Number	Part Number	FSCM	Description							Units Per Assy	Usable On Code	SMR Code														
			1	2	3	4	5	6	7																	
- 45	JAN1N5711	81349	.	S	E	M	I	C	O	N	D	.	D	I	O	4		PADZZ								
- 46	UM9301	15969	.	S	E	M	I	C	O	N	D	.	D	I	O	2		PADZZ								
- 47	52-051-0000	98291	.	C	O	N	N	E	C	T	O	R	,	P	L	U	G	,	E	L	E	C	3		PADZZ	
- 48	11-0050-00C	58167	.	C	O	N	N	E	C	T	O	R	,	P	L	U	G	,	E	L	E	C	3		PADZZ	
- 49	700-209-NP	50173	.	C	O	N	N	E	C	T	O	R	,	P	L	U	G	,	E	L	E	C	1		PADZZ	
- 50	609-2027	15912	.	C	O	N	N	E	C	T	O	R	,	R	C	P	T	,	E	L	E	C	1		PADZZ	
- 51	609-1627	15912	.	C	O	N	N	E	C	T	O	R	,	R	C	P	T	,	E	L	E	C	1		PADZZ	
- 52	503-3431	32097	.	C	O	N	N	E	C	T	O	R	,	R	C	P	T	,	E	L	E	C	1		PADZZ	
- 53	609-1027	15912	.	C	O	N	N	E	C	T	O	R	,	R	C	P	T	,	E	L	E	C	1		PADZZ	
- 54	22-11-2052	27264	.	C	O	N	N	E	C	T	O	R	,	R	C	P	T	,	E	L	E	C	1		PADZZ	
- 55	500-5027-E	15912	.	C	O	N	N	E	C	T	O	R	,	R	C	P	T	,	E	L	E	C	1		PADZZ	
- 56	MP-1142	14304	.	J	U	M	P	E	R	,	E	L	E	C	1											XB
- 57	MS75089-12	96906	.	C	O	I	L	,	R	F	2															PADZZ
- 58	MS75089-17	96906	.	C	O	I	L	,	R	F	1															PADZZ
- 59	MS90539-15	96906	.	C	O	I	L	,	R	F	3															PADZZ
- 60	MS90538-12	96906	.	C	O	I	L	,	R	F	1															PADZZ
- 61	7107-38	71279	.	C	O	I	L	,	R	F	1															PADZZ
- 62	MS18130-5	96906	.	C	O	I	L	,	R	F	2															PADZZ
- 63	MS75083-7	96906	.	C	O	I	L	,	R	F	1															PADZZ
- 64	MS75084-3	96906	.	C	O	I	L	,	R	F	2															PADZZ
- 65	MS90539-3	96906	.	C	O	I	L	,	R	F	1															PADZZ
- 66	MS14046-4	96906	.	C	O	I	L	,	R	F	2															PADZZ
- 67	MS14046-8	96906	.	C	O	I	L	,	R	F	1															PADZZ
- 68	MDLSBL1	15542	.	M	I	C	R	O	C	I	R	C	I	R	C	I	T	1								PADZZ
- 69	700425	16733	.	C	O	N	N	E	C	T	O	R	,	P	L	U	G	,	E	L	E	C	2			PADZZ
- 70	JAN2N2907A	81349	.	T	R	A	N	S	I	S	T	O	R	2												PADZZ
- 71	JAN2N2222A	81349	.	T	R	A	N	S	I	S	T	O	R	20												PADZZ
- 72	JAN2N2219A	81349	.	T	R	A	N	S	I	S	T	O	R	1												PADZZ
- 73	JAN2N2369A	81349	.	T	R	A	N	S	I	S	T	O	R	3												PADZZ
- 74	352-1042-010	13499	.	T	R	A	N	S	I	S	T	O	R	2												PADZZ
- 75	JAN2N2857	81349	.	T	R	A	N	S	I	S	T	O	R	1												PADZZ
- 76	2N4236	80131	.	T	R	A	N	S	I	S	T	O	R	2												PADZZ
- 77	U310	04713	.	T	R	A	N	S	I	S	T	O	R	2												PADZZ
- 78	1854-0583	28480	.	T	R	A	N	S	I	S	T	O	R	1												PADZZ
- 79	CF07-472J	78488	.	R	E	S	I	S	T	O	R	,	F	X	D	,	C	O	M	P	18					PADZZ
- 80	CF07-222J	78488	.	R	E	S	I	S	T	O	R	,	F	X	D	,	C	O	M	P	11					PADZZ
- 81	CF07-471J	78488	.	R	E	S	I	S	T	O	R	,	F	X	D	,	C	O	M	P	17					PADZZ
- 82	CF07-153J	78488	.	R	E	S	I	S	T	O	R	,	F	X	D	,	C	O	M	P	4					PADZZ
- 83	CF07-273J	78488	.	R	E	S	I	S	T	O	R	,	F	X	D	,	C	O	M	P	7					PADZZ
- 84	CF07-332J	78488	.	R	E	S	I	S	T	O	R	,	F	X	D	,	C	O	M	P	7					PADZZ
- 85	CF07-103J	78488	.	R	E	S	I	S	T	O	R	,	F	X	D	,	C	O	M	P	29					PADZZ
- 86	CF07-392J	78488	.	R	E	S	I	S	T	O	R	,	F	X	D	,	C	O	M	P	2					PADZZ
- 87	CF07-563J	78488	.	R	E	S	I	S	T	O	R	,	F	X	D	,	C	O	M	P	2					PADZZ
- 88	CF07-151J	78488	.	R	E	S	I	S	T	O	R	,	F	X	D	,	C	O	M	P	2					PADZZ
- 89	CF07-102J	78488	.	R	E	S	I	S	T	O	R	,	F	X	D	,	C	O	M	P	21					PADZZ
- 90	3386F-1-104	32997	.	R	E	S	I	S	T	O	R	,	V	A	R	I	A	B	L	E	2					PADZZ
- 91	RN55D6040F	81349	.	R	E	S	I	S	T	O	R	,	F	X	D	,	F	I	L	M	3					PADZZ
- 92	CF07-333J	78488	.	R	E	S	I	S	T	O	R	,	F	X	D	,	C	O	M	P	11					PADZZ
- 93	CF07-104J	78488	.	R	E	S	I	S	T	O	R	,	F	X	D	,	C	O	M	P	17					PADZZ
- 94	CF07-393J	78488	.	R	E	S	I	S	T	O	R	,	F	X	D	,	C	O	M	P	2					PADZZ
- 95	CF07-683J	78488	.	R	E	S	I	S	T	O	R	,	F	X	D	,	C	O	M	P	1					PADZZ



Figure & Index Number	Part Number	FSCM	Description							Units Per Assy	Usable On Code	SMR Code
			1	2	3	4	5	6	7			
- 96	3386F-1-102	32997	.	RESISTOR	,	VARIABLE				1		PADZZ
- 97	CF07-223J	78488	.	RESISTOR	,	FXD,COMP				5		PADZZ
- 98	CF07-562J	78488	.	RESISTOR	,	FXD,COMP				7		PADZZ
- 99	RNC55K1004FS	81349	.	RESISTOR	,	FXD,FILM				4		PADZZ
-100	RNC55K2432FS	81349	.	RESISTOR	,	FXD,FILM				1		PADZZ
-101	RNC55K3010FS	81349	.	RESISTOR	,	FXD,FILM				2		PADZZ
-102	CF07-101J	78488	.	RESISTOR	,	FXD,COMP				5		PADZZ
-103	3386B-1-504	32997	.	RESISTOR	,	VARIABLE				2		PADZZ
-104	CF07-122J	78488	.	RESISTOR	,	FXD,COMP				1		PADZZ
-105	RN55D1004F	81349	.	RESISTOR	,	FXD,FILM				4		PADZZ
-106	RNC55K4321FS	81349	.	RESISTOR	,	FXD,FILM				1		PADZZ
-107	RN55D2004F	81349	.	RESISTOR	,	FXD,FILM				2		PADZZ
-108	CF07-203J	78488	.	RESISTOR	,	FXD,COMP				1		PADZZ
-109	CF07-822J	78488	.	RESISTOR	,	FXD,COMP				1		PADZZ
-110	CF07-513J	78488	.	RESISTOR	,	FXD,COMP				1		PADZZ
-111	3386F-1-204	32997	.	RESISTOR	,	VARIABLE				1		PADZZ
-112	CF07-242J	78488	.	RESISTOR	,	FXD,COMP				4		PADZZ
-113	CF07-152J	78488	.	RESISTOR	,	FXD,COMP				2		PADZZ
-114	RNC55K1001FS	81349	.	RESISTOR	,	FXD,FILM				3		PADZZ
-115	RNC55K1000FS	81349	.	RESISTOR	,	FXD,FILM				5		PADZZ
-116	RNC55K2001FS	81349	.	RESISTOR	,	FXD,FILM				3		PADZZ
-117	RN55D1000F	81349	.	RESISTOR	,	FXD,FILM				5		PADZZ
-118	RN55D1001F	81349	.	RESISTOR	,	FXD,FILM				3		PADZZ
-119	3299W-1-101	57921	.	RESISTOR	,	VARIABLE				1		PADZZ
-120	RNC55K3011FS	81349	.	RESISTOR	,	FXD,FILM				2		PADZZ
-121	RN55D3011F	81349	.	RESISTOR	,	FXD,FILM				2		PADZZ
-122	RJR24FW503P	81349	.	RESISTOR	,	VARIABLE				1		PADZZ
-123	3386B-1-500	32997	.	RESISTOR	,	VARIABLE				1		PADZZ
-124	ERD50TJ102	54473	.	RESISTOR	,	FXD,COMP				1		PADZZ
-125	CF07-561J	78488	.	RESISTOR	,	FXD,COMP				2		PADZZ
-126	CF07-560J	78488	.	RESISTOR	,	FXD,COMP				1		PADZZ
-127	CF07-751J	78488	.	RESISTOR	,	FXD,COMP				1		PADZZ
-128	CF07-183J	78488	.	RESISTOR	,	FXD,COMP				3		PADZZ
-129	CF07-682J	78488	.	RESISTOR	,	FXD,COMP				1		PADZZ
-130	CF07-821J	78488	.	RESISTOR	,	FXD,COMP				4		PADZZ
-131	RNC55K1100FS	81349	.	RESISTOR	,	FXD,FILM				1		PADZZ
-132	RN55D2001F	81349	.	RESISTOR	,	FXD,FILM				5		PADZZ
-133	CF07-470J	78488	.	RESISTOR	,	FXD,COMP				2		PADZZ
-134	RNC55K5620FS	81349	.	RESISTOR	,	FXD,FILM				2		PADZZ
-135	RNC55K39R2FS	81349	.	RESISTOR	,	FXD,FILM				2		PADZZ
-136	RNC55K75R0FS	81349	.	RESISTOR	,	FXD,FILM				1		PADZZ
-137	CF07-221J	78488	.	RESISTOR	,	FXD,COMP				2		PADZZ
-138	3386B-1-102	32997	.	RESISTOR	,	VARIABLE				1		PADZZ
-139	72XWR5K	73138	.	RESISTOR	,	VARIABLE				1		PADZZ
-140	CF07-681J	78488	.	RESISTOR	,	FXD,COMP				1		PADZZ
-141	CF07-123J	78488	.	RESISTOR	,	FXD,COMP				2		PADZZ
-142	RNC55K2000FS	81349	.	RESISTOR	,	FXD,FILM				1		PADZZ
-143	RNC55K68R1FS	81349	.	RESISTOR	,	FXD,FILM				1		PADZZ
-144	CF07-202J	78488	.	RESISTOR	,	FXD,COMP				1		PADZZ
-145	CF07-201J	78488	.	RESISTOR	,	FXD,COMP				1		PADZZ
-146	RN55D3510F	81349	.	RESISTOR	,	FXD,FILM				2		PADZZ

Figure & Index Number	Part Number	FSCM	Description							Units Per Assy	Usable On Code	SMR Code
			1	2	3	4	5	6	7			
-147	RNC55K1503FS	81349	.							2		PADZZ
-148	RNC55K4322FS	81349	.							1		PADZZ
-149	RN55D6812F	81349	.							1		PADZZ
-150	RNC55K1652FS	81349	.							1		PADZZ
-151	RN55D1503F	81349	.							2		PADZZ
-152	CF07-220J	78488	.							4		PADZZ
-153	CF07-334J	78488	.							1		PADZZ
-154	RNC55K3322FS	81349	.							1		PADZZ
-155	RNC55K7501FS	81349	.							1		PADZZ
-156	RNC55K3922FS	81349	.							1		PADZZ
-157	CF07-473J	78488	.							3		PADZZ
-158	RNC55K2431FS	81349	.							1		PADZZ
-159	RNC55K6980FS	81349	.							1		PADZZ
-160	RN55D3010F	81349	.							2		PADZZ
-161	CF07-182J	78488	.							2		PADZZ
-162	CF07-270J	78488	.							1		PADZZ
-163	RNC55K47R5FS	81349	.							1		PADZZ
-164	RN55D39R2F	81349	.							2		PADZZ
-165	RN55D5620F	81349	.							2		PADZZ
-166	CF07-391J	78488	.							1		PADZZ
-167	RNC55K4021FS	81349	.							1		PADZZ
-168	CF07-331J	78488	.							3		PADZZ
-169	ERD50TJ561	54473	.							1		PADZZ
-170	CF07-224J	78488	.							1		PADZZ
-171	3386B-1-103	32997	.							1		PADZZ
-172	CF07-271J	78488	.							1		PADZZ
-173	RNC55K3482FS	81349	.							1		PADZZ
-174	RNC55K1372FS	81349	.							1		PADZZ
-175	RNC55K1332FS	81349	.							1		PADZZ
-176	RNC55K1002FS	81349	.							1		PADZZ
-177	CF07-154J	78488	.							1		PADZZ
-178	RN55K4320FS	81349	.							2		PADZZ
-179	RN55D4320F	81349	.							2		PADZZ
-180	RNC55K1151FS	81349	.							2		PADZZ
-181	RN55D1151F	81349	.							2		PADZZ
-182	TY-304P	81095	.							1		PADZZ
-183	105-0858-001	74970	.							1		PADZZ
-184	105-0852-001	74970	.							1		PADZZ
-185	105-0856-001	74970	.							1		PADZZ
-186	105-0857-001	74970	.							1		PADZZ
-187	SN54LS26J	01295	.							1		PADZZ
-188	351-8434-010	13499	.							8		PADZZ
-189	CD4053BF	02735	.							8		PADZZ
-190	NE571N	18324	.							3		PADZZ
-191	SA571F	18324	.							2		PADZZ
-192	ULQ-2003R	56289	.							1		PADZZ
-193	SA572F	18324	.							1		PADZZ
-194	1596/BCBJC	04713	.							1		PADZZ
-195	MM54C14J	04713	.							1		PADZZ
-196	10085-9560	14304	.							1		PADZZ
-197	M38510/008021BCB	81349	.							1		PADZZ

Figure & Index Number	Part Number	FSCM	Description							Units Per Assy	Usable On Code	SMR Code
			1	2	3	4	5	6	7			
-198	M38510/30701BEB	81349	.							1		PADZZ
-199	M38510/32204BEB	81349	.							1		PADZZ
-200	CD4094BF	02735	.							4		PADZZ
-201	CD4021BF	02735	.							1		PADZZ
-202	LH0070-OH	27014	.							1		PADZZ
-203	M38510/31005BCB	81349	.							1		PADZZ
-204	JAN1N751A	81349	.							2		PADZZ
-205	JAN1N750A	81349	.							3		PADZZ
-206	10085-5425	14304	.							1		PADZZ
-207	10085-5409	14304	.							1		XA
-208	6611-0135	14304	.							8		XB
-209	10085-5156	14304	.							8		XB
-210	MS35489-4	96906	.							4		XB
-211	MS51957-17	96906	.							8		PAOZZ
-212	MS35338-135	96906	.							8		PADZZ

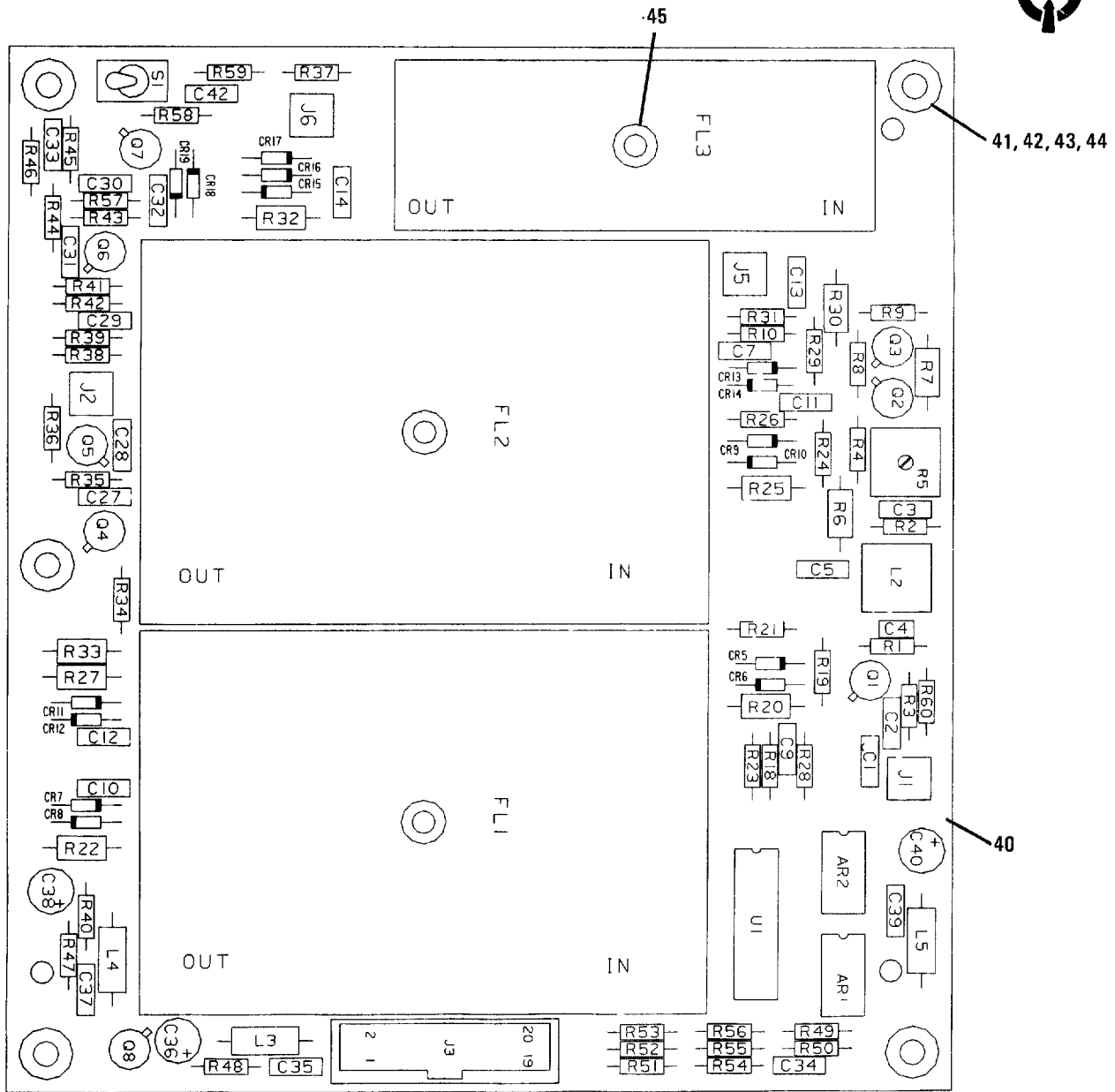

350-111

Figure 7-12. IF Filter PWB Assy, A1A2

## NOTE

To find index numbers for circuit board components, use the reference designator index at the end of this chapter. The complete reference designator for a circuit board component consists of "1," followed by the assembly designator (A1A1, A1A2, etc.), then the reference designator on the illustration. For example, the complete reference designator for R25 on the Exciter PWB Assy is 1A1A1 R25.

Figure & Index Number	Part Number	FSCM	Description	Units Per Assy	Usable On Code	SMR Code
7-12-	10085-5300	14304	CIRCUIT CARD ASSY,A1A2	1		PAODD
- 1	MC1558U	04713	. MICROCIRCUIT	2		PADZZ
- 2	CK06BX104K	81349	. CAPACITOR,FXD,CER	11		PADZZ
- 3	CK06BX474K	81349	. CAPACITOR,FXD,CER	12		PADZZ
- 4	CK05BX181K	81349	. CAPACITOR,FXD,CER	1		PADZZ
- 5	T392C106M025AS	31433	. CAP,FXD,ELCTLT	3		PADZZ
- 6	JAN1N4454	81349	. SEMICOND DEVICE,DIO	15		PADZZ
- 7	10085-5331	14304	. FILTER	1		PADZZ
- 8	10085-5321	14304	. FILTER	1		PADZZ
- 9	10085-5340	14304	. FILTER	1		PADZZ
- 10	700-209-NP	50173	. CONNECTOR,PLUG,ELEC	4		PADZZ
- 11	609-2027	15912	. CONNECTOR,RCPT,ELEC	1		PADZZ
- 12	9208	81564	. COIL,RF	1		PADZZ
- 13	MS14046-8	96906	. COIL,RF	3		PADZZ
- 14	U310	04713	. TRANSISTOR	1		PADZZ
- 15	JAN2N2222A	81349	. TRANSISTOR	5		PADZZ
- 16	JAN2N2907A	81349	. TRANSISTOR	2		PADZZ
- 17	CF07-561J	78488	. RESISTOR,FXD,COMP	2		PADZZ
- 18	CF07-101J	78488	. RESISTOR,FXD,COMP	11		PADZZ
- 19	CF07-471J	78488	. RESISTOR,FXD,COMP	4		PADZZ
- 20	CF07-221J	78488	. RESISTOR,FXD,COMP	1		PADZZ
- 21	3386F-1-102	32997	. RESISTOR,VARIABLE	1		PADZZ
- 22	RNC55K5231FS	81349	. RESISTOR,FXD,FILM	1		PADZZ
- 23	RNC55K2211FS	81349	. RESISTOR,FXD,FILM	1		PADZZ
- 24	CF07-510J	78488	. RESISTOR,FXD,COMP	1		PADZZ
- 25	CF07-102J	78488	. RESISTOR,FXD,COMP	5		PADZZ
- 26	CF07-222J	78488	. RESISTOR,FXD,COMP	3		PADZZ
- 27	RNC55K5111FS	81349	. RESISTOR,FXD,FILM	3		PADZZ
- 28	RN55D1002F	81349	. RESISTOR,FXD,FILM	4		PADZZ
- 29	RN55D5111F	81349	. RESISTOR,FXD,FILM	3		PADZZ
- 30	CF07-682J	78488	. RESISTOR,FXD,COMP	1		PADZZ
- 31	CF07-331J	78488	. RESISTOR,FXD,COMP	1		PADZZ
- 32	CF07-103J	78488	. RESISTOR,FXD,COMP	5		PADZZ
- 33	CF07-472J	78488	. RESISTOR,FXD,COMP	1		PADZZ
- 34	CF07-272J	78488	. RESISTOR,FXD,COMP	2		PADZZ
- 35	CF07-152J	78488	. RESISTOR,FXD,COMP	1		PADZZ
- 36	CF07-104J	78488	. RESISTOR,FXD,COMP	4		PADZZ
- 37	CF07-153J	78488	. RESISTOR,FXD,COMP	1		PADZZ
- 38	T101LH9V3BE	09353	. SWITCH	1		PADZZ
- 39	7704701EB	14933	. MICROCIRCUIT	1		PADZZ
- 40	10085-5309	14304	. CIRCUIT CARD	1		XA
- 41	6611-0135	14304	. RETAINER,SCREW	5		PADZZ
- 42	10085-5156	14304	. BUSHING	5		PADZZ
- 43	MS51957-17	96906	. SCREW,MACHINE (AP)	5		PADZZ
- 44	MS35338-135	96906	. WASHER,SPLIT (AP)	5		PADZZ
- 45	H-6769	14304	. NUT,CLINCH (AP)	3		XB

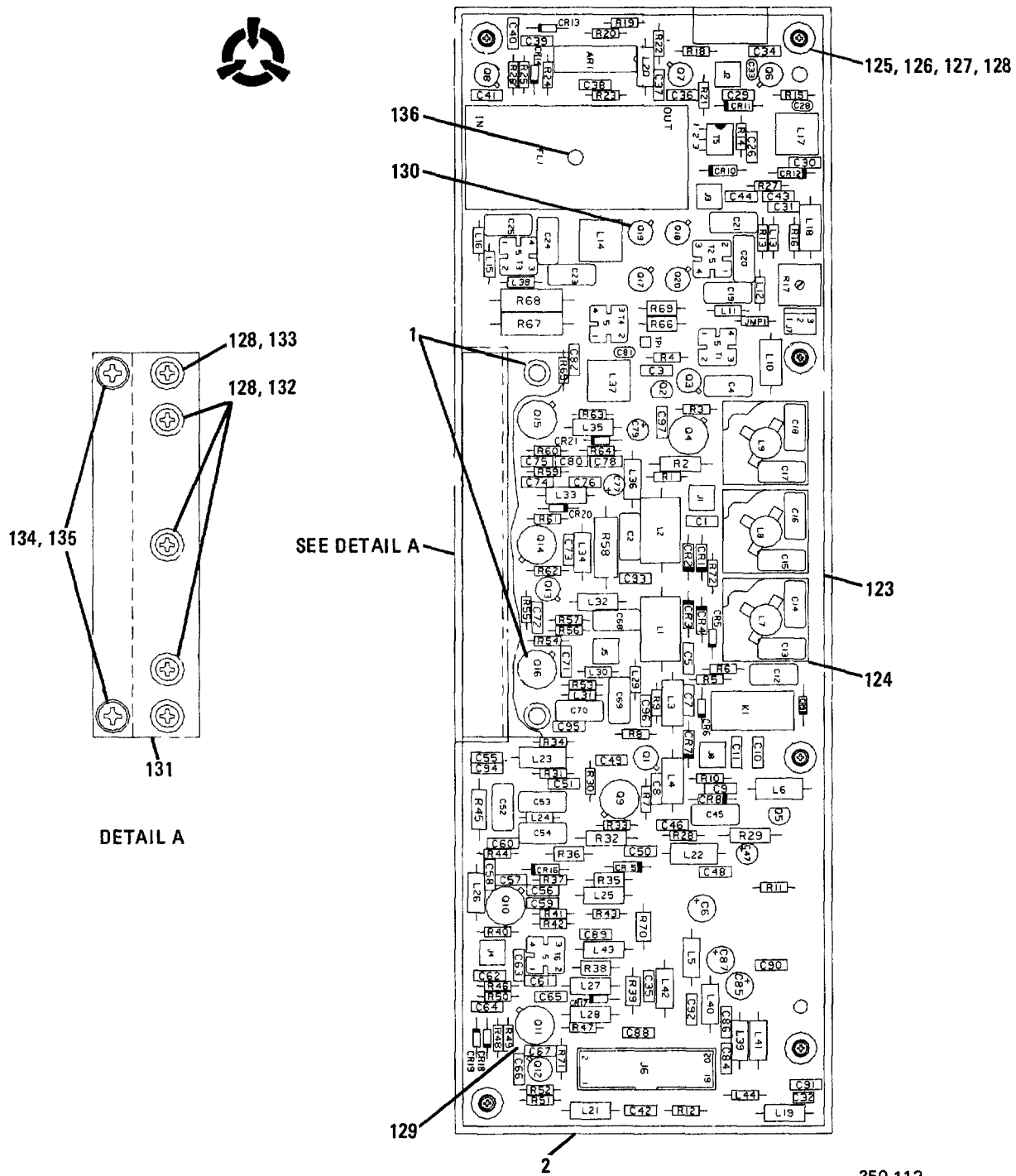

Figure 7-13. First Converter PWB Assy, A1A3

## NOTE

To find index numbers for circuit board components, use the reference designator index at the end of this chapter. The complete reference designator for a circuit board component consists of "1," followed by the assembly designator (A1A1, A1A2, etc.), then the reference designator on the illustration. For example, the complete reference designator for R25 on the Exciter PWB Assy is 1A1A1 R25.

Figure & Index Number	Part Number	FSCM	Description							Units Per Assy	Usable On Code	SMR Code
			1	2	3	4	5	6	7			
7-13-	10085-5000	14304	CIRCUIT CARD ASSY,A1A3							1		PAODD
- 1	KFB3-440-18ET	06540	. SPACER							2		XB
- 2	10085-5161	14304	. COVER, CON.							1		XB
- 3	U6A7733312	97942	. MICROCIRCUIT							1		PADZZ
- 4	M39014/02-1342	81349	. CAPACITOR, FXD, CER							1		PADZZ
- 5	CM05ED330J03	81349	. CAPACITOR, FXD, MICA							4		PADZZ
- 6	CK06BX104K	81349	. CAPACITOR, FXD, CER							24		PADZZ
- 7	CMR05F391GODR	81349	. CAPACITOR, FXD, MICA							1		PADZZ
- 8	T392C226M010AS	31433	. CAP, FXD, ELECTLT							1		PADZZ
- 9	CMR05E360GODR	81349	. CAP, FXD, MICA							2		PADZZ
- 10	CMR05E270GODR	81349	. CAP FXD MICA							2		PADZZ
- 11	CMR05F101GODR	81349	. CAP FXD MICA							4		PADZZ
- 12	CMR05F910GODR	81349	. CAP, FXD MICA							1		PADZZ
- 13	CMR05E820GODR	81349	. CAP, FXD MICA							2		PADZZ
- 14	CMR05E560GODR	81349	. CAPACITOR, FXD, MICA							1		PADZZ
- 15	CM05FD101J03	81349	. CAP FXD MICA							4		PADZZ
- 16	CM05ED360J03	81349	. CAP, FXD, MICA							2		PADZZ
- 17	CM05ED820G03	81349	. CAP, FXD MICA							2		PADZZ
- 18	CM05ED270G03	81349	. CAP FXD MICA							2		PADZZ
- 19	CMR05F271GODR	81349	. CAP FXD MICA							2		PADZZ
- 20	CM05FD271J03	81349	. CAP FXD MICA							2		PADZZ
- 21	CMR05E750GODR	81349	. CAP, FXD MICA							1		PADZZ
- 22	CK06BX103K	81349	. CAPACITOR, FXD, CER							31		PADZZ
- 23	DR10DB229J	93958	. CAP, FXD CER							1		PADZZ
- 24	CK05BX102K	81349	. CAPACITOR, FXD, CER							2		PADZZ
- 25	DR10DB829J	93958	. CAP FXD CER							1		PADZZ
- 26	T392B155M035AS	31433	. CAP, FXD, ELCTLT							1		PADZZ
- 27	CK06BX474K	81349	. CAPACITOR, FXD, CER							2		PADZZ
- 28	CMR05E680GODR	81349	. CAP, FXD MICA							2		PADZZ
- 29	CMR05C150J0DR	81349	. CAP, FXD MICA							1		PADZZ
- 30	CM05ED680G03	81349	. CAP, FXD MICA							2		PADZZ
- 31	M39014/02-1334	81349	. CAPACITOR, FXD, CER							1		PADZZ
- 32	10085-5012	14304	. CAPACITOR, FXD, CER							1		PADZZ
- 33	TAPF3.3K25	61725	. CAP, FXD, ELCTLT							2		PADZZ
- 34	TAPF3.3M25	31433	. CAP, FXD, ELCTLT							2		PADZZ
- 35	DR10DB569J	93958	. CAP FXD CER							1		PADZZ
- 36	TAPF10M25	31433	. CAP, FXD, ELCTLT							2		PADZZ
- 37	UES1103	12969	. SEMICOND DEVICE DIO							4		PADZZ
- 38	JAN1N4454	81349	. SEMICOND DEVICE, DIO							7		PADZZ
- 39	5082-3168	98734	. SEMICOND DEVICE, DIO							4		PADZZ
- 40	UM9301	15969	. SEMICOND DEVICE, DIO							3		PADZZ
- 41	JAN1N5711	81349	. SEMICOND DEVICE, DIO							2		PADZZ
- 42	10085-5020	14304	. FILTER							1		PADZZ
- 43	700-209-NP	50173	. CONNECTOR, PLUG, ELEC							5		PADZZ
- 44	609-2027	15912	. CONNECTOR, RCPT, ELEC							1		PADZZ

Figure & Index Number	Part Number	FSCM	Description							Units Per Assy	Usable On Code	SMR Code
			1	2	3	4	5	6	7			
- 45	22-11-2032	27264	.	CONN	RECP	ELECT				1		PADZZ
- 46	MP-1142	14304	.	JUMPER	,ELEC					1		PADZZ
- 47	10085-5019	14304	.	HEATSINK						2		XB
- 48	MS90539-7	96906	.	COIL	RF					3		PADZZ
- 49	MS18130-11	96906	.	COIL	RF					1		PADZZ
- 50	L-0255	14304	.	COIL	,RF					2		PADZZ
- 51	L-0254	14304	.	COIL	,RF					1		PADZZ
- 52	MS75087-5	96906	.	COIL	,RF					1		PADZZ
- 53	MS75083-2	96906	.	COIL	RF					1		PADZZ
- 54	MS75083-5	96906	.	COIL	RF					1		PADZZ
- 55	MS75083-1	96906	.	COIL	RF					2		PADZZ
- 56	8962	81564	.	COIL	RF					1		PADZZ
- 57	MS75083-3	96906	.	COIL	RF					2		PADZZ
- 58	8966	81564	.	COIL	,RF					1		PADZZ
- 59	MS18130-15	96906	.	COIL	RF					1		PADZZ
- 60	MS14046-8	96906	.	COIL	,RF					4		PADZZ
- 61	MS14046-1	96906	.	COIL	,RF					7		PADZZ
- 62	MS90539-3	96906	.	COIL	,RF					2		PADZZ
- 63	MS75083-8	96906	.	COIL	RF					1		PADZZ
- 64	MS18130-14	96906	.	COIL	,RF					1		PADZZ
- 65	MS90538-20	96906	.	COIL	,RF					2		PADZZ
- 66	MS75083-6	96906	.	COIL	RF					2		PADZZ
- 67	MS18130-5	96906	.	COIL	,RF					1		PADZZ
- 68	MS14046-4	96906	.	COIL	,RF					2		PADZZ
- 69	L11-0004-017	14304	.	COIL	RF					1		PADZZ
- 70	MS75083-13	96906	.	COIL	RF					1		PADZZ
- 71	JAN2N2907A	81349	.	TRANSISTOR						2		PADZZ
- 72	MPS-A18	04713	.	TRANSISTOR						1		PADZZ
- 73	JAN2N2222A	81349	.	TRANSISTOR						3		PADZZ
- 74	JAN2N3439	81349	.	TRANSISTOR						1		PADZZ
- 75	U310	04713	.	TRANSISTOR						2		PADZZ
- 76	JAN2N3866A	81349	.	TRANSISTOR						5		PADZZ
- 77	2N5160	81349	.	TRANSISTOR						1		PADZZ
- 78	ON947	34553	.	TRANSISTOR						3		PADZZ
- 79	CF07-470J	78488	.	RESISTOR	,FXD	,COMP				4		PADZZ
- 80	CF07-473J	78488	.	RESISTOR	,FXD	,COMP				1		PADZZ
- 81	ERD50TJ154	54473	.	RESISTOR	,FXD	,COMP				1		PADZZ
- 82	CF07-103J	78488	.	RESISTOR	,FXD	,COMP				4		PADZZ
- 83	CF07-4R7J	78488	.	RESISTOR	,FXD	,COMP				2		PADZZ
- 84	CF07-153J	78488	.	RESISTOR	,FXD	,COMP				2		PADZZ
- 85	CF07-562J	78488	.	RESISTOR	,FXD	,COMP				2		PADZZ
- 86	CF07-822J	78488	.	RESISTOR	,FXD	,COMP				1		PADZZ
- 87	CF07-680J	78488	.	RESISTOR	,FXD	,COMP				2		PADZZ
- 88	CF07-681J	78488	.	RESISTOR	,FXD	,COMP				1		PADZZ
- 89	3386F-1-502	32997	.	RESISTOR	,VARIABLE					1		PADZZ
- 90	CF07-682J	78488	.	RESISTOR	,FXD	,COMP				3		PADZZ
- 91	CF07-101J	78488	.	RESISTOR	,FXD	,COMP				2		PADZZ
- 92	CF07-221J	78488	.	RESISTOR	,FXD	,COMP				3		PADZZ
- 93	CF07-821J	78488	.	RESISTOR	,FXD	,COMP				2		PADZZ
- 94	CF07-104J	78488	.	RESISTOR	,FXD	,COMP				2		PADZZ
- 95	CF07-152J	78488	.	RESISTOR	,FXD	,COMP				1		PADZZ



Figure & Index Number	Part Number	FSCM	Description							Units Per Assy	Usable On Code	SMR Code
			1	2	3	4	5	6	7			
- 96	ERD50TJ151	54473	.	RESISTOR, FXD, COMP						3		PADZZ
- 97	CF07-471J	78488	.	RESISTOR, FXD, COMP						4		PADZZ
- 98	CF07-820J	78488	.	RESISTOR, FXD, COMP						1		PADZZ
- 99	RNC55K1821FS	81349	.	RESISTOR FXD FILM						1		PADZZ
-100	RNC55K27R4FS	81349	.	RESISTOR FXD FILM						1		PADZZ
-101	RN55D2431F	81349	.	RESISTOR, FXD, FILM						1		PADZZ
-102	RN55D6980F	81349	.	RESISTOR, FXD, FILM						1		PADZZ
-103	CF07-122J	78488	.	RESISTOR, FXD, COMP						1		PADZZ
-104	CF07-151J	78488	.	RESISTOR, FXD, COMP						3		PADZZ
-105	CF07-100J	78488	.	RESISTOR, FXD, COMP						4		PADZZ
-106	CF07-561J	78488	.	RESISTOR, FXD, COMP						1		PADZZ
-107	CF07-102J	78488	.	RESISTOR, FXD, COMP						2		PADZZ
-108	CF07-222J	78488	.	RESISTOR, FXD, COMP						1		PADZZ
-109	CF07-472J	78488	.	RESISTOR, FXD, COMP						1		PADZZ
-110	RCR32G820JS	81349	.	RESISTOR, FXD, COMP						1		PADZZ
-111	CF07-392J	78488	.	RESISTOR, FXD, COMP						2		PAODD
-112	RNC55K8251FS	81349	.	RESISTOR, FXD, FILM						1		PADZZ
-113	RCR32G151JS	81349	.	RESISTOR, FXD, COMP						2		PADZZ
-114	RCR32G151JM	81349	.	RESISTOR, FXD, COMP						2		PADZZ
-115	RNC55K2212FS	81349	.	RESISTOR, FXD, FILM						1		PADZZ
-116	RN55D3010F	81349	.	RESISTOR, FXD, FILM						1		PADZZ
-117	10085-5013	14304	.	TRANSFORMER, RF						1		PADZZ
-118	10085-5021	14304	.	TRANSFORMER, RF						1		PADZZ
-119	10085-5023	14304	.	TRANSFORMER, RF						1		PADZZ
-120	10085-5022	14304	.	TRANSFORMER, RF						1		PADZZ
-121	10085-5014	14304	.	TRANSFORMER, RF						1		PADZZ
-122	65499-101	22526	.	CONNECTOR, PLUG, ELEC						1		PADZZ
-123	10085-5009	14304	.	CIRCUIT CARD						1		XA
-124	260-4TH5B	90372	.	HEATSINK						3		XB
-125	6611-0135	14304	.	RETAINER, SCREW						6		PADZZ
-126	10085-5156	14304	.	BUSHING						6		PADZZ
-127	MS51957-17	96906	.	SCREW, MACHINE (AP)						6		PADZZ
-128	MS35338-135	96906	.	WASHER, SPLIT (AP)						11		PADZZ
-129	11737761	19200	.	PAD, MTG, ELEC, CMPNT						7		PADZZ
-130	7717-89-DAP	13103	.	MTG PAD, ELEC, CMPNT						4		PADZZ
-131	10085-5016	14304	.	HEATSINK						1		XB
-132	MS51957-13	96906	.	SCREW, MACHINE (AP)						3		PAOZZ
-133	MS51957-14	96906	.	SCREW, MACHINE (AP)						2		PAOZZ
-134	10085-5131	14304	.	SCREW, MACHINE (AP)						2		PAOZZ
-135	MS35338-136	96906	.	WASHER, SPLIT (AP)						2		PADZZ
-136	841-00	92967	.	NUT, CLINCH (AP)						1		PADZZ
-137	18097B-B0440-14	46384	.	SPACER						2		XB

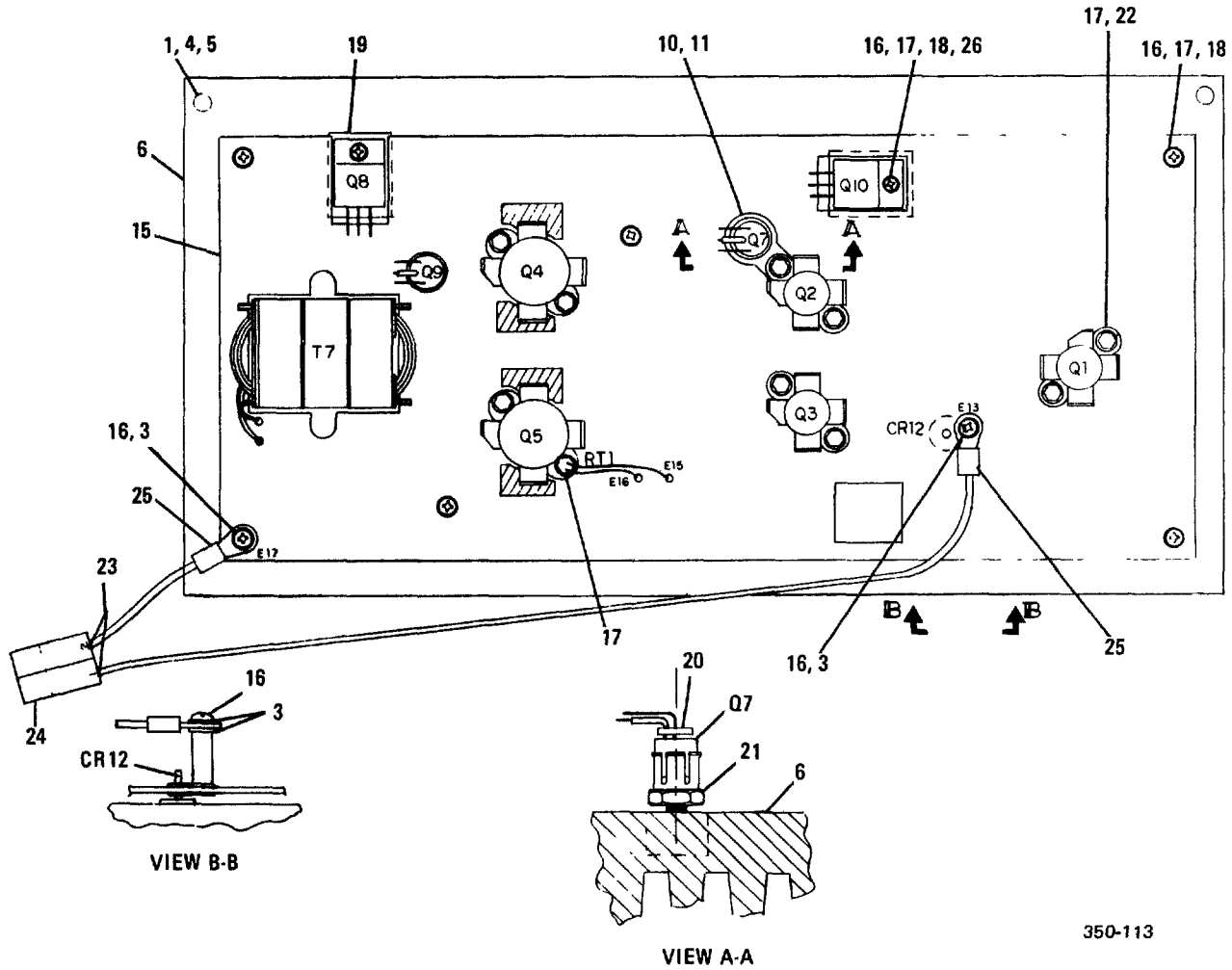

350-113

Figure 7-14. Power Amplifier Assy, A1A4

## NOTE

To find index numbers for circuit board components, use the reference designator index at the end of this chapter. The complete reference designator for a circuit board component consists of "1," followed by the assembly designator (A1A1, A1A2, etc.), then the reference designator on the illustration. For example, the complete reference designator for R25 on the Exciter PWB Assy is 1A1A1 R25.

Figure & Index Number	Part Number	FSCM	Description							Units Per Assy	Usable On Code	SMR Code
			1	2	3	4	5	6	7			
7-14-	10085-8010	14304	100W PA, 12V, ASSY, A1A4							1		PAOLD
- 1	MS15795-805	96906	. WASHER, FLAT (AP)							2		PADZZ
- 2	MS51957-14	96906	. WASHER, FLAT (AP)							1		PADZZ
- 3	MS35333-70	96906	. WASHER, LOCK (AP)							3		PAOZZ
- 4	MS35338-136	96906	. WASHER, SPLIT (AP)							2		PADZZ
- 5	6241-SS-0632-17	06540	. SCREW, MACHINE (AP)							2		XB
- 6	10085-5180	14304	. HEATSINK							1		XB
- 7	MR5005R	04713	. SEMICOND DEVICE, DIO							1		PADZZ
- 8	PT4371A	71785	. TRANSISTOR							1		PADZZ
- 9	PT4371B	71785	. TRANSISTOR							1		PADZZ
- 10	PT4371C	71785	. TRANSISTOR							1		PADZZ
- 11	JAN2N2219A	81349	. TRANSISTOR							2		PADZZ
- 12	TIP120	01295	. TRANSISTOR							2		PADZZ
- 13	6628-1050	14304	. RESISTOR, THERMAL							1		PAOZZ
- 14	10085-8165	14304	. TRANSFORMER, RF							1		PADZZ
- 15	10085-8100	14304	. CIRCUIT CARD ASSY							1		PADLD
- 16	MS51957-16	96906	. SCREW, MACHINE (AP)							9		PAOZZ
- 17	MS35338-135	96906	. WASHER, SPLIT (AP)							17		PADZZ
- 18	MS15795-803	96906	. WASHER, FLAT (AP)							7		PADZZ
- 19	7403-09FR-51	55285	. INSULATOR, ELEC.							2		PADZZ
- 20	7717-15-DAP	13103	. MTG PAD. ELEC CMPNT							2		XB
- 21	260-6SH5E	90372	. HEATSINK							2		XB
- 22	MS16995-10	96906	. SCREW, MACHINE (AP)							9		PAOZZ
- 23	53892-4	00779	. CONTACT, ELECTRICAL							2		PADZZ
- 24	54483-2	00779	. CONNECTOR, RCPT, ELEC							1		PADZZ
- 25	MS25036-111	96906	. TERMINAL, LUG							2		PADZZ
- 26	7721-7PPS	13103	. INSULATOR BUSHING							2		PADZZ

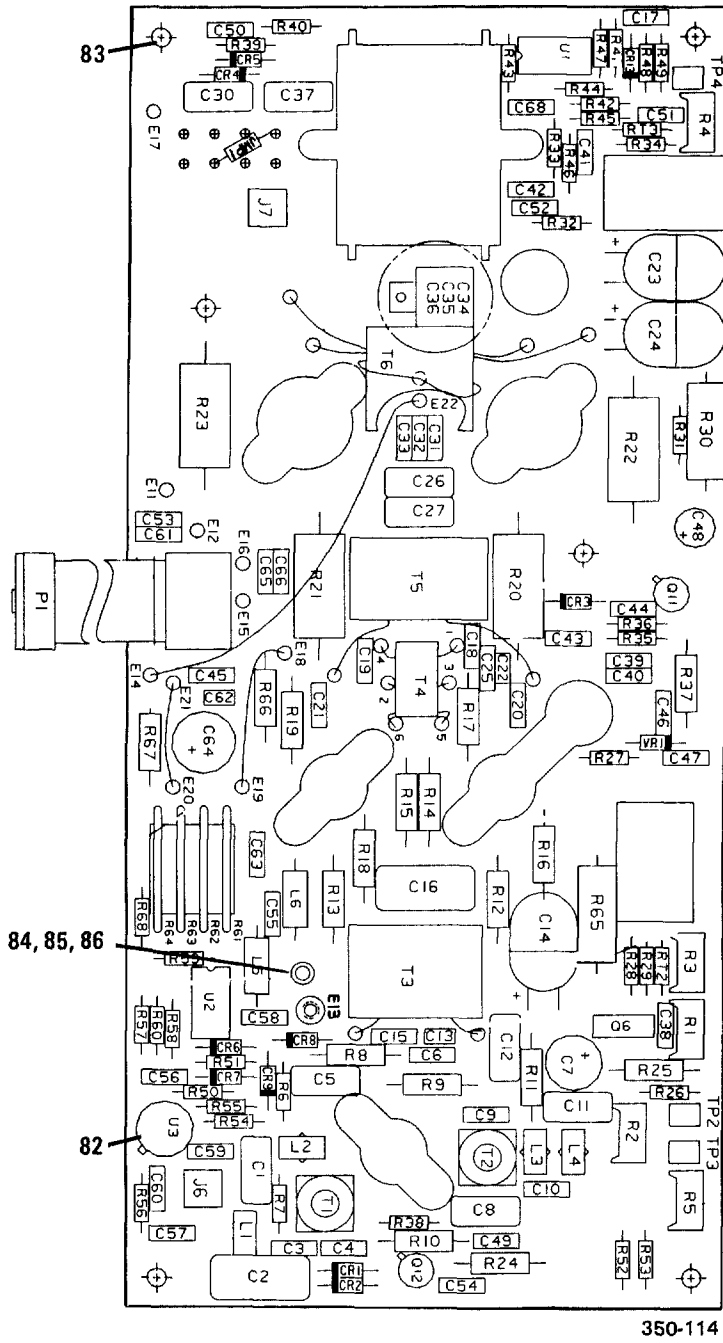

Figure 7-15. Power Amplifier PWB Assy, A1A4A1

## NOTE

To find index numbers for circuit board components, use the reference designator index at the end of this chapter. The complete reference designator for a circuit board component consists of "1," followed by the assembly designator (A1A1, A1A2, etc.), then the reference designator on the illustration. For example, the complete reference designator for R25 on the Exciter PWB Assy is 1A1A1 R25.

Figure & Index Number	Part Number	FSCM	Description							Units Per Assy	Usable On Code	SMR Code
			1	2	3	4	5	6	7			
7-15-	10085-8100	14304	CIRCUIT CARD ASSY,A1A4A1							1		PADLDT
- 1	CM05FD331G03	81349	. CAPACITOR, FXD, MICA							2		PADZZ
- 2	CM06FD821J03	81349	. CAPACITOR, FXD, MICA							2		PADZZ
- 3	CK06BX104K	81349	. CAPACITOR, FXD, CER							41		PADZZ
- 4	CM05FD391J03	81349	. CAPACITOR, FXD, MICA							1		PADZZ
- 5	106RAR050APX	74840	. CAP, FXD, ELCTLT							1		PADZZ
- 6	CMR05F121GODR	81349	. CAPACITOR, FXD, MICA							1		PADZZ
- 7	CK05BX102K	81349	. CAPACITOR, FXD, CER							3		PADZZ
- 8	199D687X9003FE2	56289	. CAP FXD ELECTLT							1		PADZZ
- 9	CMR06F431GODI	81349	. CAPACITOR, FXD, MICA							1		PADZZ
- 10	199D337X96R3FE2	56289	. CAP, FXD, ELCTLT							2		PADZZ
- 11	199D337X06R3EA2	56289	. CAP, FXD, ELCTLT							2		PADZZ
- 12	CM06FD102J03	81349	. CAPACITOR, FXD, MICA							1		PADZZ
- 13	CM06FD112J03	81349	. CAPACITOR, FXD, MICA							1		PADZZ
- 14	CM05FD361G03	81349	. CAPACITOR, FXD, MICA							1		PADZZ
- 15	C45-0002-621	14304	. CAPACITOR, FXD, MICA							1		PADZZ
- 16	C45-0002-751	14304	. CAPACITOR, FXD, MICA							1		PADZZ
- 17	CM05ED360J03	81349	. CAP, FXD, MICA							1		PADZZ
- 18	T392C226M010AS	31433	. CAP, FXD, ELECTLT							1		PADZZ
- 19	CK06BX474K	81349	. CAPACITOR, FXD, CER							1		PADZZ
- 20	25VBSL100	00493	. CAP, FXD, ELCTLT							1		PADZZ
- 21	JAN1N4454	81349	. SEMICOND DEVICE, DIO							9		PADZZ
- 22	JAN1N3611	81349	. SEMICOND DEVICE, DIO							9		PADZZ
- 23	700-209-NP	50173	. CONNECTOR, PLUG, ELEC							2		PADZZ
- 24	MP-1142	14304	. JUMPER, ELEC							1		PADZZ
- 25	10085-8110	14304	. COIL, RF							2		PADZZ
- 26	10085-8111	14304	. COIL, RF							2		PADZZ
- 27	1025-48	71895	. COIL, RF							2		PADZZ
- 28	10085-0350	14304	. CABLE ASSY, RF							1		PAOZZ
- 29	TIP120	01295	. TRANSISTOR							1		PADZZ
- 30	JAN2N2907A	81349	. TRANSISTOR							1		PADZZ
- 31	JAN2N2222A	81349	. TRANSISTOR							1		PADZZ
- 32	3386B-1-102	32997	. RESISTOR, VARIABLE							1		PADZZ
- 33	3386B-1-101	32997	. RESISTOR, VARIABLE							2		PADZZ
- 34	3386B-1-201	32997	. RESISTOR, VARIABLE							2		PADZZ
- 35	CF07-910J	78488	. RESISTOR, FXD, COMP							1		PADZZ
- 36	CF07-510J	78488	. RESISTOR, FXD, COMP							1		PADZZ
- 37	ERD50TJ121	54473	. RESISTOR, FXD, COMP							1		PADZZ
- 38	ERD50TJ109	54473	. RESISTOR, FXD, COMP							2		PADZZ
- 39	ERD50TJ270	54473	. RESISTOR, FXD, COMP							1		PADZZ
- 40	ERD50TJ680	54473	. RESISTOR, FXD, COMP							2		PADZZ
- 41	ERD50TJ150	54473	. RESISTOR, FXD, COMP							2		PADZZ
- 42	RSF-1A	56637	. RESISTOR, FXD, COMP							5		PADZZ
- 43	RCR42G100JS	81349	. RESISTOR, FXD, COMP							4		PADZZ
- 44	RCR42G100JM	81349	. RESISTOR, FXD, COMP							4		PADZZ

Figure & Index Number	Part Number	FSCM	Description							Units Per Assy	Usable On Code	SMR Code
			1	2	3	4	5	6	7			
- 45	ERD50TJ271	54473	.	RESISTOR	,FXD	,COMP				2		PADZZ
- 46	ERD50TJ479	54473	.	RESISTOR	,FXD	,COMP				2		PADZZ
- 47	CF07-181J	78488	.	RESISTOR	,FXD	,COMP				2		PADZZ
- 48	CF07-471J	78488	.	RESISTOR	,FXD	,COMP				2		PADZZ
- 49	CF07-102J	78488	.	RESISTOR	,FXD	,COMP				5		PADZZ
- 50	CF07-470J	78488	.	RESISTOR	,FXD	,COMP				2		PADZZ
- 51	573S1R00K	44655	.	RESISTOR	,FXD	,WW				2		PADZZ
- 52	CF07-821J	78488	.	RESISTOR	,FXD	,COMP				1		PADZZ
- 53	CF07-822J	78488	.	RESISTOR	,FXD	,COMP				2		PADZZ
- 54	CF07-101J	78488	.	RESISTOR	,FXD	,COMP				1		PADZZ
- 55	CF07-473J	78488	.	RESISTOR	,FXD	,COMP				1		PADZZ
- 56	CF07-105J	78488	.	RESISTOR	,FXD	,COMP				2		PADZZ
- 57	CF07-184J	78488	.	RESISTOR	,FXD	,COMP				1		PADZZ
- 58	CF07-103J	78488	.	RESISTOR	,FXD	,COMP				2		PADZZ
- 59	CF07-152J	78488	.	RESISTOR	,FXD	,COMP				3		PADZZ
- 60	CF07-203J	78488	.	RESISTOR	,FXD	,COMP				1		PADZZ
- 61	CF07-122J	78488	.	RESISTOR	,FXD	,COMP				2		PADZZ
- 62	CF07-620J	78488	.	RESISTOR	,FXD	,COMP				1		PADZZ
- 63	CF07-161J	78488	.	RESISTOR	,FXD	,COMP				2		PADZZ
- 64	CF07-750J	78488	.	RESISTOR	,FXD	,COMP				1		PADZZ
- 65	CF07-511J	78488	.	RESISTOR	,FXD	,COMP				1		PADZZ
- 66	CF07-393J	78488	.	RESISTOR	,FXD	,COMP				2		PADZZ
- 67	10029-0211	14304	.	RESISTOR	,WIRE					4		PADZZ
- 68	1K-201-J	50157	.	TEMPISTOR						2		PADZZ
- 69	10085-8130	14304	.	TRANSFORMER	,RF					1		PADZZ
- 70	10085-8140	14304	.	TRANSFORMER	,RF					1		PADZZ
- 71	10085-8191	14304	.	TRANSFORMER	,RF					2		PADZZ
- 72	10085-8170	14304	.	TRANSFORMER	,RF					1		PADZZ
- 73	10085-8180	14304	.	TRANSFORMER	,RF					1		PADZZ
- 74	105-1102-001	74970	.	JACK	,TIP					1		PADZZ
- 75	105-1106-001	74970	.	JACK	,TIP					1		PADZZ
- 76	105-1107-001	74970	.	JACK	,TIP					1		PADZZ
- 77	LM2904N	27014	.	MICROCIRCUIT						1		PADZZ
- 78	MC1558U	04713	.	MICROCIRCUIT						1		PADZZ
- 79	2N3806	80131	.	TRANSISTOR						1		PADZZ
- 80	JAN1N4461	81349	.	TRANSISTOR						1		PADZZ
- 81	10085-8109	14304	.	CIRCUIT CARD						1		XA
- 82	7717-240DAP	13103	.	MTG PAD	,ELEC	,CMPNT				1		XB
- 83	18296B-B.129-14	46384	.	SPACER						6		XB
- 84	18097B-B0440-14	46384	.	SPACER						1		PADZZ
- 85	SE-54	07707	.	EYELET METALLIC						1		PADZZ
- 86	MS35333-72	96906	.	WASHER	,LOCK (AP)					1		PADZZ



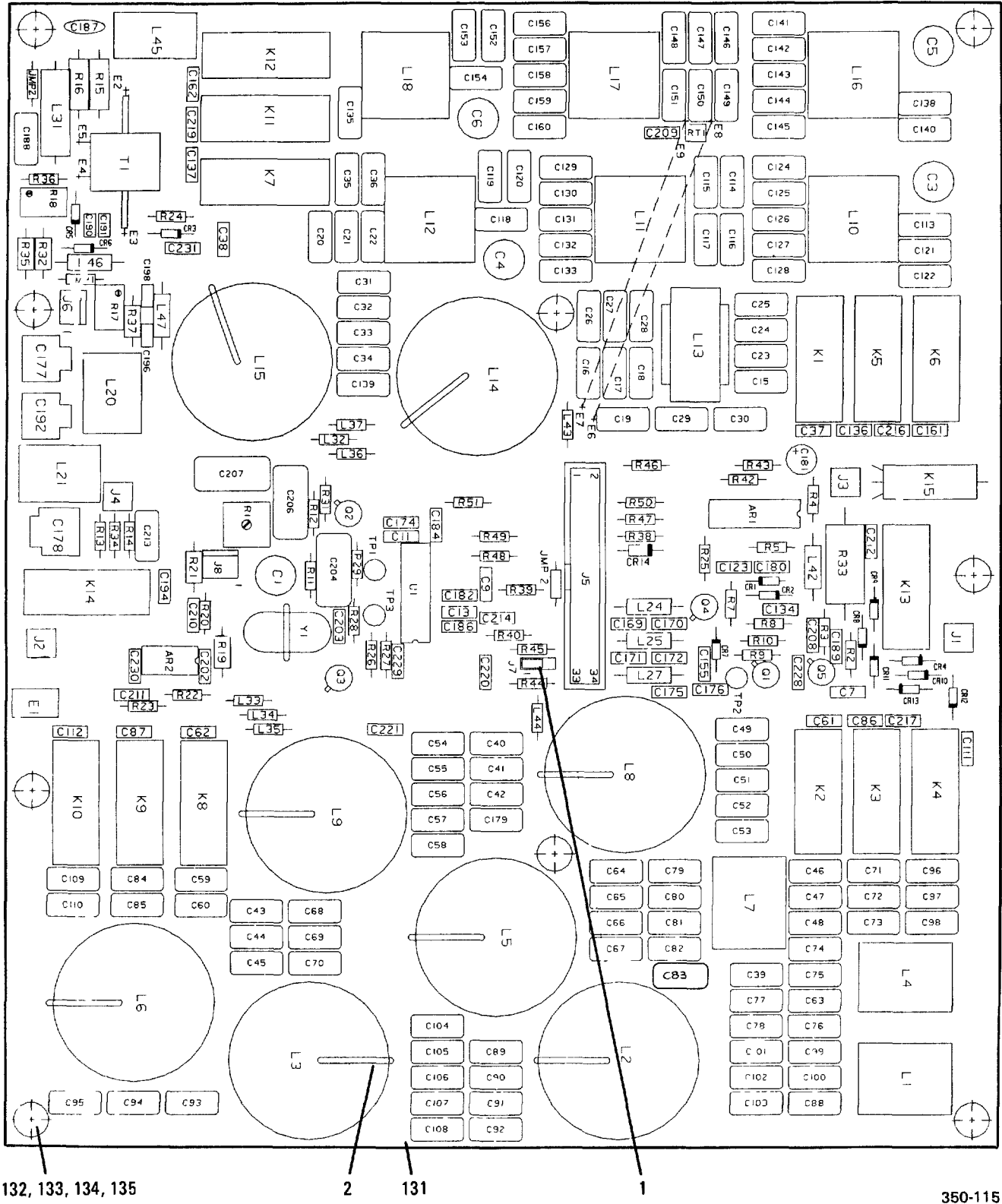

Figure 7-16. Low Pass Filter PWB Assy, A1A5



## NOTE

To find index numbers for circuit board components, use the reference designator index at the end of this chapter. The complete reference designator for a circuit board component consists of "1," followed by the assembly designator (A1A1, A1A2, etc.), then the reference designator on the illustration. For example, the complete reference designator for R25 on the Exciter PWB Assy is 1A1A1 R25.

Figure & Index Number	Part Number	FSCM	Description 1 2 3 4 5 6 7	Units Per Assy	Usable On Code	SMR Code
7-16-	10085-4000	14304	CIRCUIT CARD ASSY,A1A5	1		PAOLD
- 1	65474-001	00779	. JUMPER,ELEC	1		XB
- 2	MS3367-4-9	96906	. STRAP,TIE DOWN	8		PAOZZ
- 3	MC1733L	04713	. MICROCIRCUIT	1		PADZZ
- 4	MC1558U	04713	. MICROCIRCUIT	1		PADZZ
- 5	CU31E600	81349	. CAPACITOR,VARIABLE	1		PADZZ
- 6	DV11PS25B	73899	. CAPACITOR,VARIABLE	4		PADZZ
- 7	CV31B250	16546	. CAPACITOR,VARIABLE	4		PADZZ
- 8	CK06BX104K	81349	. CAPACITOR,FXD,CER	44		PADZZ
- 9	CMR05F151GODR	81349	. CAPACITOR,FXD,MICA	5		PADZZ
- 10	CMR05F181GODR	81349	. CAPACITOR,FXD,MICA	8		PADZZ
- 11	CM05FD181G03	81349	. CAPACITOR,FXD,MICA	8		PADZZ
- 12	DM-15-500J	00853	. CAPACITOR,FXD,MICA	2		PADZZ
- 13	CM05FD910G03	81349	. CAP,FXD MICA	1		PADZZ
- 14	CM05FD361G03	81349	. CAPACITOR,FXD,MICA	5		PADZZ
- 15	CM05FD331G03	81349	. CAPACITOR,FXD,MICA	4		PADZZ
- 16	CMR05F301GODR	81349	. CAPACITOR,FXD,MICA	2		PADZZ
- 17	DM15F431-G	72136	. CAPACITOR,FXD,MICA	1		PADZZ
- 18	CM05ED820G03	81349	. CAP,FXD MICA	7		PADZZ
- 19	CMR05F111GODR	81349	. CAPACITOR,FXD,MICA	7		PADZZ
- 20	CM05FD111G03	81349	. CAPACITOR,FXD,MICA	7		PADZZ
- 21	CMR05F201GODR	81349	. CAPACITOR,FXD,MICA	6		PADZZ
- 22	CMR05F221GODR	81349	. CAPACITOR,FXD,MICA	6		PADZZ
- 23	DM-15-250J	00853	. CAPACITOR,FXD,MICA	2		PADZZ
- 24	CM05FD201G03	81349	. CAPACITOR,FXD,MICA	6		PADZZ
- 25	CM05FD221G03	81349	. CAPACITOR,FXD,MICA	6		PADZZ
- 26	CMR05F241GODR	81349	. CAPACITOR,FXD,MICA	1		PADZZ
- 27	CM05ED560G03	81349	. CAPACITOR,FXD,MICA	2		PADZZ
- 28	CM05ED680G03	81349	. CAP,FXD MICA	14		PADZZ
- 29	CMR05F131GODR	81349	. CAPACITOR,FXD,MICA	5		PADZZ
- 30	CM05FD151G03	81349	. CAPACITOR,FXD,MICA	5		PADZZ
- 31	CM05FD131G03	81349	. CAPACITOR,FXD,MICA	5		PADZZ
- 32	CM05FD121G03	81349	. CAPACITOR,FXD,MICA	5		PADZZ
- 33	CMR05E300GODR	81349	. CAPACITOR,FXD,MICA	3		PADZZ
- 34	CMR05E470GODR	81349	. CAPACITOR,FXD,MICA	7		PADZZ
- 35	CM05ED470G03	81349	. CAPACITOR,FXD,MICA	7		PADZZ
- 36	CMR05E430GODR	81349	. CAPACITOR,FXD,MICA	8		PADZZ
- 37	CM05ED430G03	81349	. CAPACITOR,FXD,MICA	8		PADZZ
- 38	CM05ED750G03	81349	. CAP,FXD MICA	3		PADZZ
- 39	DM-15-20J	00853	. CAPACITOR,FXD,MICA	9		PADZZ
- 40	CM05ED270G03	81349	. CAP FXD MICA	2		PADZZ
- 41	DM-15-24J	00853	. CAPACITOR,FXD,MICA	6		PADZZ
- 42	CK06BX103K	81349	. CAPACITOR,FXD,CER	5		PADZZ
- 43	CMR05E390GODR	81349	. CAPACITOR,FXD,MICA	5		PADZZ
- 44	CM05ED390G03	81349	. CAPACITOR,FXD,MICA	5		PADZZ

Figure & Index Number	Part Number	FSCM	Description							Units Per Assy	Usable On Code	SMR Code
			1	2	3	4	5	6	7			
- 45	CM05FD301G03	81349	.	CAPACITOR	,FXD	,MICA				2		PADZZ
- 46	CMR05C5R0D0DR	81349	.	CAPACITOR	,FXD	,MICA				1		PADZZ
- 47	DM-15-18J	00853	.	CAPACITOR	,FXD	,MICA				7		PADZZ
- 48	CM05ED300G03	81349	.	CAPACITOR	,FXD	,MICA				3		PADZZ
- 49	CMR05C100D0DR	81349	.	CAPACITOR	,FXD	,MICA				2		PADZZ
- 50	CM05CD100D03	81349	.	CAPACITOR	,FXD	,MICA				2		PADZZ
- 51	MCM01-007EC670G0	61306	.	CAPACITOR	,FXD	,CER				2		PADZZ
- 52	T392C106M025AS	31433	.	CAP	,FXD	,ELCTLT				1		PADZZ
- 53	O831000COG0120G	18796	.	CAPACITOR	,FXD	,CER				1		PADZZ
- 54	CK05BX102K	81349	.	CAPACITOR	,FXD	,CER				2		PADZZ
- 55	MCM01-007FC1420G0	61306	.	CAPACITOR	,FXD	,CER				1		PADZZ
- 56	CK05BX471K	81349	.	CAPACITOR	,FXD	,CER				2		PADZZ
- 57	CMR06F222G0DR	81349	.	CAPACITOR	,FXD	,MICA				2		PADZZ
- 58	CM06FD821J03	81349	.	CAPACITOR	,FXD	,MICA				1		PADZZ
- 59	CM06FD222J03	81349	.	CAPACITOR	,FXD	,MICA				2		PADZZ
- 60	JAN1N4454	81349	.	SEMICOND DEVICE	,DIO					11		PADZZ
- 61	JAN1N5711	81349	.	SEMICOND DEVICE	,DIO					3		PADZZ
- 62	4520000	96238	.	ARRESTOR	,SURGE	,ELEC				1		PADZZ
- 63	700-209-NP	50173	.	CONNECTOR	,PLUG	,ELEC				4		PADZZ
- 64	609-3427	15912	.	CONNECTOR	,RCPT	,ELEC				1		PADZZ
- 65	22-11-2032	27264	.	CONN RECP	ELECT					1		PADZZ
- 66	65499-103	22526	.	TEST POINT						1		XB
- 67	MP-1142	14304	.	JUMPER	,ELEC					1		PADZZ
- 68	NT1-DC12V	61529	.	RELAY						14		PADZZ
- 69	1A12A	21317	.	RELAY						1		PADZZ
- 70	10077	81564	.	COIL	,RF					1		PADZZ
- 71	10078	81564	.	COIL	,RF					1		PADZZ
- 72	10245	81564	.	COIL	,RF					1		PADZZ
- 73	10079	81564	.	COIL	,RF					1		PADZZ
- 74	10080	81564	.	COIL	,RF					1		PADZZ
- 75	10081	81564	.	COIL	,RF					1		PADZZ
- 76	10082	81564	.	COIL	,RF					1		PADZZ
- 77	10083	81564	.	COIL	,RF					1		PADZZ
- 78	10084	81564	.	COIL	,RF					1		PADZZ
- 79	10085-4030	14304	.	COIL	,RF					1		PADZZ
- 80	10085-4031	14304	.	COIL	,RF					1		PADZZ
- 81	10085-4032	14304	.	COIL	,RF					1		PADZZ
- 82	10088	81564	.	COIL	,RF					1		PADZZ
- 83	10089	81564	.	COIL	,RF					1		PADZZ
- 84	10175	81564	.	COIL	,RF					1		PADZZ
- 85	10085-4033	14304	.	COIL	,RF					1		PADZZ
- 86	10085-4034	14304	.	COIL	,RF					1		PADZZ
- 87	10085-4035	14304	.	COIL	,RF					1		PADZZ
- 88	10085-4020	14304	.	COIL	,RF					2		PADZZ
- 89	MS14046-8	96906	.	COIL	,RF					4		PADZZ
- 90	MS90541-5	96906	.	COIL	,RF					1		PADZZ
- 91	MS75084-12	96906	.	COIL	,RF					8		PADZZ
- 92	10085-4022	14304	.	COIL	,RF					1		PADZZ
- 93	MS90538-12	96906	.	COIL	,RF					2		PADZZ
- 94	MS75083-5	96906	.	COIL	RF					1		PADZZ
- 95	JAN2N2907A	81349	.	TRANSISTOR						2		PADZZ

Figure & Index Number	Part Number	FSCM	Description							Units Per Assy	Usable On Code	SMR Code
			1	2	3	4	5	6	7			
- 96	JAN2N2222A	81349	.	TRANSISTOR						2		PADZZ
- 97	U310	04713	.	TRANSISTOR						1		PADZZ
- 98	3386B-1-501	32997	.	RESISTOR, VARIABLE						1		PADZZ
- 99	CF07-104J	78488	.	RESISTOR, FXD, COMP						2		PADZZ
-100	CF07-221J	78488	.	RESISTOR, FXD, COMP						2		PADZZ
-101	CF07-101J	78488	.	RESISTOR, FXD, COMP						3		PADZZ
-102	CF07-682J	78488	.	RESISTOR, FXD, COMP						2		PADZZ
-103	CF07-122J	78488	.	RESISTOR, FXD, COMP						1		PADZZ
-104	CF07-471J	78488	.	RESISTOR, FXD, COMP						4		PADZZ
-105	CF07-103J	78488	.	RESISTOR, FXD, COMP						5		PADZZ
-106	CF07-510J	78488	.	RESISTOR, FXD, COMP						2		PADZZ
-107	CF07-154J	78488	.	RESISTOR, FXD, COMP						1		PADZZ
-108	RNC60K56R2FS	81349	.	RESISTOR, FXD, FILM						2		PADZZ
-109	RN60D56R2F	81349	.	RESISTOR, FXD, FILM						2		PADZZ
-110	3299W-1-103	32997	.	RESISTOR, VARIABLE						1		PADZZ
-111	RJR24FW202P	81349	.	RESISTOR, VARIABLE						1		PADZZ
-112	RNC55K1212FS	81349	.	RESISTOR, FXD, FILM						1		PADZZ
-113	CF07-474J	78488	.	RESISTOR, FXD, COMP						1		PADZZ
-114	RN55D8251F	81349	.	RESISTOR, FXD, FILM						1		PADZZ
-115	CF07-821J	78488	.	RESISTOR, FXD, COMP						1		PADZZ
-116	CF07-391J	78488	.	RESISTOR, FXD, COMP						1		PADZZ
-117	CF07-272J	78488	.	RESISTOR, FXD, COMP						8		PADZZ
-118	CF07-222J	78488	.	RESISTOR, FXD, COMP						1		PADZZ
-119	RNC55K5761FS	81349	.	RESISTOR, FXD, FILM						1		PADZZ
-120	RCR42G103JS	81349	.	RESISTOR, FXD, COMP						1		PADZZ
-121	RN55D6812F	81349	.	RESISTOR, FXD, FILM						2		PADZZ
-122	CF07-332J	78488	.	RESISTOR, FXD, COMP						1		PADZZ
-123	CF07-102J	78488	.	RESISTOR, FXD, COMP						2		PADZZ
-124	KT45J3	15801	.	THERMISTOR						1		PADZZ
-125	10085-4010	14304	.	TRANSFORMER, RF						1		PADZZ
-126	105-0858-001	74970	.	JACK, TIP						1		PADZZ
-127	105-0852-001	74970	.	JACK, TIP						1		PADZZ
-128	105-0856-001	74970	.	JACK, TIP						1		PADZZ
-129	ULQ-2003R	56289	.	MICROCIRCUIT						1		PADZZ
-130	6911-3102	14304	.	CRYSTAL						1		PADZZ
-131	10085-4009	14304	.	CIRCUIT CARD						1		XA
-132	MS35338-135	96906	.	WASHER, SPLIT (AP)						9		PADZZ
-133	6611-0135	14304	.	RETAINER, SCREW						9		PADZZ
-134	10085-5156	14304	.	BUSHING						9		PADZZ
-135	MS51957-17	96906	.	SCREW, MACHINE (AP)						9		PADZZ

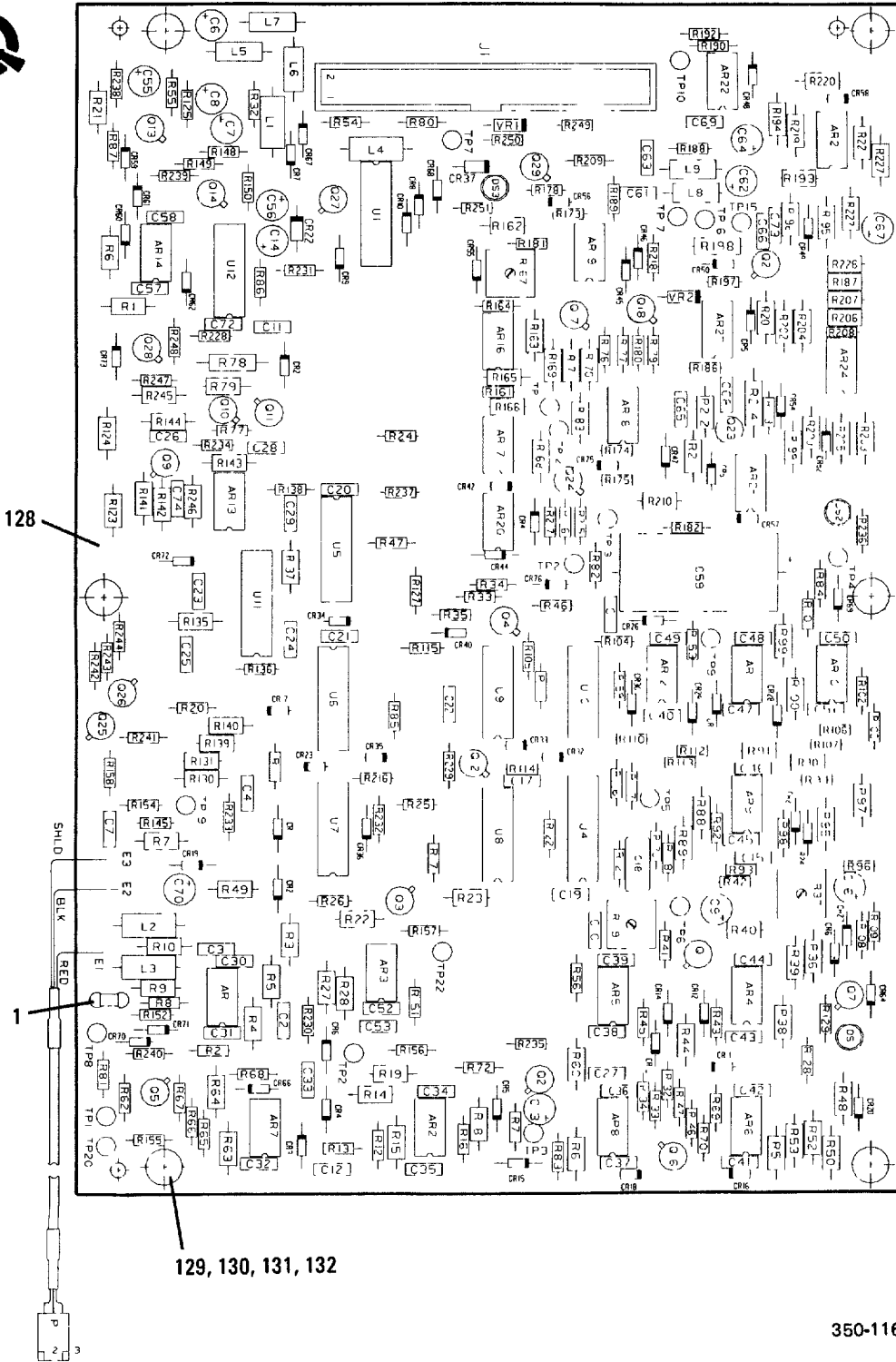

Figure 7-17. AGC/TGC PWB Assy, A1A6

## NOTE

To find index numbers for circuit board components, use the reference designator index at the end of this chapter. The complete reference designator for a circuit board component consists of "1," followed by the assembly designator (A1A1, A1A2, etc.), then the reference designator on the illustration. For example, the complete reference designator for R25 on the Exciter PWB Assy is 1A1A1 R25.

Figure & Index Number	Part Number	FSCM	Description							Units Per Assy	Usable On Code	SMR Code
			1	2	3	4	5	6	7			
7-17-	10085-5250	14304	CIRCUIT CARD ASSY,A1A6							1		PAODD
- 1	MS3367-4-9	96906	. STRAP,TIE DOWN							1		PADZZ
- 2	MC1558U	04713	. MICROCIRCUIT							22		PADZZ
- 3	TL071MJG	01295	. MICROCIRCUIT							2		PADZZ
- 4	CK05BX471K	81349	. CAPACITOR,FXD,CER							4		PADZZ
- 5	CK06BX104K	81349	. CAPACITOR,FXD,CER							12		PADZZ
- 6	T392C106M025AS	31433	. CAP,FXD,ELCTLT							13		PADZZ
- 7	CK06BX103K	81349	. CAPACITOR,FXD,CER							38		PADZZ
- 8	CK05BX102K	81349	. CAPACITOR,FXD,CER							1		PADZZ
- 9	CM05FD391J03	81349	. CAPACITOR,FXD,MICA							1		PADZZ
- 10	106JP5RWD1250	19396	. CAPACITOR,FXD,PLSTC							1		PADZZ
- 11	M39014/02-1347	81349	. CAPACITOR,FXD,CER							1		PADZZ
- 12	JAN1N4454	81349	. SEMICOND DEVICE,DIO							69		PADZZ
- 13	JAN1N3611	81349	. SEMICOND DEVICE,DIO							2		PADZZ
- 14	HLMP-3301	50434	. LED							3		PADZZ
- 15	HLMP-3401	50434	. LED							1		PADZZ
- 16	5082-4655	01295	. LED							1		PADZZ
- 17	500-5027-E	15912	. CONNECTOR,RCPT,ELEC							1		PADZZ
- 18	MS90539-15	96906	. COIL,RF							1		PADZZ
- 19	MS90539-3	96906	. COIL,RF							3		PADZZ
- 20	MS14046-8	96906	. COIL,RF							5		PADZZ
- 21	08-56-0110	27264	. CONTACT ELECTRICAL							3		PADZZ
- 22	22-01-3037	27264	. CONNECTOR,PLUG,ELEC							1		PADZZ
- 23	2N5566	80131	. TRANSISTOR							2		PADZZ
- 24	JAN2N2222A	81349	. TRANSISTOR							16		PADZZ
- 25	JAN2N2907A	81349	. TRANSISTOR							5		PADZZ
- 26	RNC55K1003FS	81349	. RESISTOR,FXD,FILM							5		PADZZ
- 27	CF07-333J	78488	. RESISTOR,FXD,COMP							4		PADZZ
- 28	RN55D6812F	81349	. RESISTOR,FXD,FILM							5		PADZZ
- 29	RN55D3323F	81349	. RESISTOR,FXD,FILM							3		PADZZ
- 30	RN55D1003F	81349	. RESISTOR,FXD,FILM							5		PADZZ
- 31	RNC55K2742FS	81349	. RESISTOR,FXD,FILM							1		PADZZ
- 32	CF07-222J	78488	. RESISTOR,FXD,COMP							9		PADZZ
- 33	CF07-682J	78488	. RESISTOR,FXD,COMP							2		PADZZ
- 34	RN55D1002F	81349	. RESISTOR,FXD,FILM							21		PADZZ
- 35	RNC55K1402FS	81349	. RESISTOR,FXD,FILM							2		PADZZ
- 36	CF07-473J	78488	. RESISTOR,FXD,COMP							7		PADZZ
- 37	CF07-103J	78488	. RESISTOR,FXD,COMP							37		PADZZ
- 38	RN55D2432F	81349	. RESISTOR,FXD,FILM							3		PADZZ
- 39	RN55D3322F	81349	. RESISTOR,FXD,COMP							3		PADZZ
- 40	RN55D4422F	81349	. RESISTOR,FXD,FILM							3		PADZZ
- 41	RNC55K2671FS	81349	. RESISTOR,FXD,FILM							1		PADZZ
- 42	CF07-472J	78488	. RESISTOR,FXD,COMP							7		PADZZ
- 43	RNC55K3162FS	81349	. RESISTOR,FXD,FILM							1		PADZZ
- 44	CF07-223J	78488	. RESISTOR,FXD,COMP							8		PADZZ

Figure & Index Number	Part Number	FSCM	Description							Units Per Assy	Usable On Code	SMR Code
			1	2	3	4	5	6	7			
- 45	RNC55K6191FS	81349	.	RESISTOR	,FXD	,FILM				1		PADZZ
- 46	3386F-1-102	32997	.	RESISTOR	,VARIABLE					1		PADZZ
- 47	RNC55K6811FS	81349	.	RESISTOR	,FXD	,FILM				1		PADZZ
- 48	RN55D2211F	81349	.	RESISTOR	,FXD	,FILM				4		PADZZ
- 49	CF07-104J	78488	.	RESISTOR	,FXD	,COMP				11		PADZZ
- 50	CF07-101J	78488	.	RESISTOR	,FXD	,COMP				4		PADZZ
- 51	RNC55K5901FS	81349	.	RESISTOR	,FXD	,FILM				2		PADZZ
- 52	RNC55K1782FS	81349	.	RESISTOR	,FXD	,FILM				1		PADZZ
- 53	RNC55K5112FS	81349	.	RESISTOR	,FXD	,FILM				1		PADZZ
- 54	CF07-561J	78488	.	RESISTOR	,FXD	,COMP				3		PADZZ
- 55	RN55D1212F	81349	.	RESISTOR	,FXD	,FILM				3		PADZZ
- 56	RNC55K3321FS	81349	.	RESISTOR	,FXD	,FILM				1		PADZZ
- 57	CF07-474J	78488	.	RESISTOR	,FXD	,COMP				1		PADZZ
- 58	CF07-272J	78488	.	RESISTOR	,FXD	,COMP				1		PADZZ
- 59	CF07-102J	78488	.	RESISTOR	,FXD	,COMP				11		PADZZ
- 60	CF07-334J	78488	.	RESISTOR	,FXD	,COMP				3		PADZZ
- 61	ERD50TJ271	54473	.	RESISTOR	,FXD	,COMP				1		PADZZ
- 62	CF07-100J	78488	.	RESISTOR	,FXD	,COMP				4		PADZZ
- 63	CF07-224J	78488	.	RESISTOR	,FXD	,COMP				1		PADZZ
- 64	CF07-471J	78488	.	RESISTOR	,FXD	,COMP				2		PADZZ
- 65	RNC55K2210FS	81349	.	RESISTOR	FXD	FILM				1		PADZZ
- 66	CF07-105J	78488	.	RESISTOR	,FXD	,COMP				2		PADZZ
- 67	CF07-562J	78488	.	RESISTOR	,FXD	,COMP				6		PADZZ
- 68	CF07-183J	78488	.	RESISTOR	,FXD	,COMP				2		PADZZ
- 69	CF07-184J	78488	.	RESISTOR	,FXD	,COMP				1		PADZZ
- 70	3386F-1-203	32997	.	RESISTOR	,VARIABLE					1		PADZZ
- 71	RN55D1503F	81349	.	RESISTOR	,FXD	,FILM				1		PADZZ
- 72	RNC55K2002FS	81349	.	RESISTOR	FXD	FILM				1		PADZZ
- 73	RN55D1652F	81349	.	RESISTOR	,FXD	,FILM				1		PADZZ
- 74	RNC55K4991FS	81349	.	RESISTOR	,FXD	,FILM				2		PADZZ
- 75	RNC55K4751FS	81349	.	RESISTOR	,FXD	,FILM				2		PADZZ
- 76	RN55D4751F	81349	.	RESISTOR	,FXD	,FILM				2		PADZZ
- 77	RN55D1332F	81349	.	RESISTOR	,FXD	,FILM				1		PADZZ
- 78	3386F-1-103	32997	.	RESISTOR	,VARIABLE					1		PADZZ
- 79	RN55D5901F	81349	.	RESISTOR	,FXD	,FILM				2		PADZZ
- 80	RN55D8251F	81349	.	RESISTOR	,FXD	,FILM				1		PADZZ
- 81	RNC55K2263FS	81349	.	RESISTOR	,FXD	,FILM				1		PADZZ
- 82	RN55D1824F	81349	.	RESISTOR	,FXD	,FILM				1		PADZZ
- 83	CF07-273J	78488	.	RESISTOR	,FXD	,COMP				4		PADZZ
- 84	CF07-153J	78488	.	RESISTOR	,FXD	,COMP				1		PADZZ
- 85	RN55D7501F	81349	.	RESISTOR	,FXD	,FILM				1		PADZZ
- 86	CF07-563J	78488	.	RESISTOR	,FXD	,COMP				1		PADZZ
- 87	CF07-681J	78488	.	RESISTOR	,FXD	,COMP				2		PADZZ
- 88	RN55D1402F	81349	.	RESISTOR	,FXD	,FILM				2		PADZZ
- 89	ERD50TJ331	54473	.	RESISTOR	,FXD	,COMP				2		PADZZ
- 90	RNC55K5232FS	81349	.	RESISTOR	,FXD	,FILM				1		PADZZ
- 91	RNC55K1622FS	81349	.	RESISTOR	,FXD	,FILM				1		PADZZ
- 92	RNC55K1302FS	81349	.	RESISTOR	,FXD	,FILM				1		PADZZ
- 93	RNC55K6192FS	81349	.	RESISTOR	,FXD	,FILM				1		PADZZ
- 94	RNC55K1743FS	81349	.	RESISTOR	,FXD	,FILM				1		PADZZ
- 95	CF07-221J	78488	.	RESISTOR	,FXD	,COMP				3		PADZZ

Figure & Index Number	Part Number	FSCM	Description							Units Per Assy	Usable On Code	SMR Code
			1	2	3	4	5	6	7			
- 96	RNC55K1822FS	81349	.	RESISTOR	,FXD	,FILM				1		PADZZ
- 97	RNC55K4122FS	81349	.	RESISTOR	,FXD	,FILM				1		PADZZ
- 98	CF07-151J	78488	.	RESISTOR	,FXD	,COMP				1		PADZZ
- 99	RNC55K1303FS	81349	.	RESISTOR	,FXD	,COMP				1		PADZZ
-100	RNC55K5622FS	81349	.	RESISTOR	,FXD	,COMP				1		PADZZ
-101	RNC55K9090FS	81349	.	RESISTOR	,FXD	,COMP				1		PADZZ
-102	RN55D6980F	81349	.	RESISTOR	,FXD	,FILM				1		PADZZ
-103	CF07-121J	78488	.	RESISTOR	,FXD	,COMP				1		PADZZ
-104	CF07-821J	78488	.	RESISTOR	,FXD	,COMP				2		PADZZ
-105	RN55D1821F	81349	.	RESISTOR	FXD	FILM				1		PADZZ
-106	RN55D4991F	81349	.	RESISTOR	,FXD	,FILM				2		PADZZ
-107	105-0858-001	74970	.	JACK	,TIP					3		PADZZ
-108	105-0852-001	74970	.	JACK	,TIP					3		PADZZ
-109	105-0856-001	74970	.	JACK	,TIP					2		PADZZ
-110	105-0857-001	74970	.	JACK	,TIP					1		PADZZ
-111	105-854	74970	.	JACK	,TIP					2		PADZZ
-112	105-0860-001	74970	.	JACK	,TIP					2		PADZZ
-113	105-0862-001	74970	.	JACK	,TIP					2		PADZZ
-114	105-0864-001	74970	.	JACK	,TIP					1		PADZZ
-115	105-0851-001	74970	.	JACK	,TIP					2		PADZZ
-116	105-0853-001	74970	.	JACK	,TIP					2		PADZZ
-117	105-0854-001	74970	.	JACK	,TIP					2		PADZZ
-118	CD4094BF	02735	.	MICROCIRCUIT						1		PADZZ
-119	CD4536BF	02735	.	MICROCIRCUIT						1		PADZZ
-120	CD4516BF	02735	.	MICROCIRCUIT						2		PADZZ
-121	7901101CB	14933	.	MICROCIRCUIT						1		PADZZ
-122	CD4030BF	02735	.	MICROCIRCUIT						2		PADZZ
-123	CD4012BF	02735	.	MICROCIRCUIT						1		PADZZ
-124	CD4011BD/3	02735	.	MICROCIRCUIT						1		PADZZ
-125	DAC-08F	18324	.	MICROCIRCUIT						1		PADZZ
-126	JAN1N966B	81349	.	SEMICOND DEVICE	DIO					1		PADZZ
-127	JAN1N759A	81349	.	SEMICOND DEVICE	,DIO					1		PADZZ
-128	10085-5259	14304	.	CIRCUIT CARD						1		XA
-129	6611-0135	14304	.	RETAINER	,SCREW					6		PADZZ
-130	10085-5156	14304	.	BUSHING						6		PADZZ
-131	MS51957-17	96906	.	SCREW	,MACHINE (AP)					6		PADZZ
-132	MS35338-135	96906	.	WASHER	,SPLIT (AP)					6		PADZZ

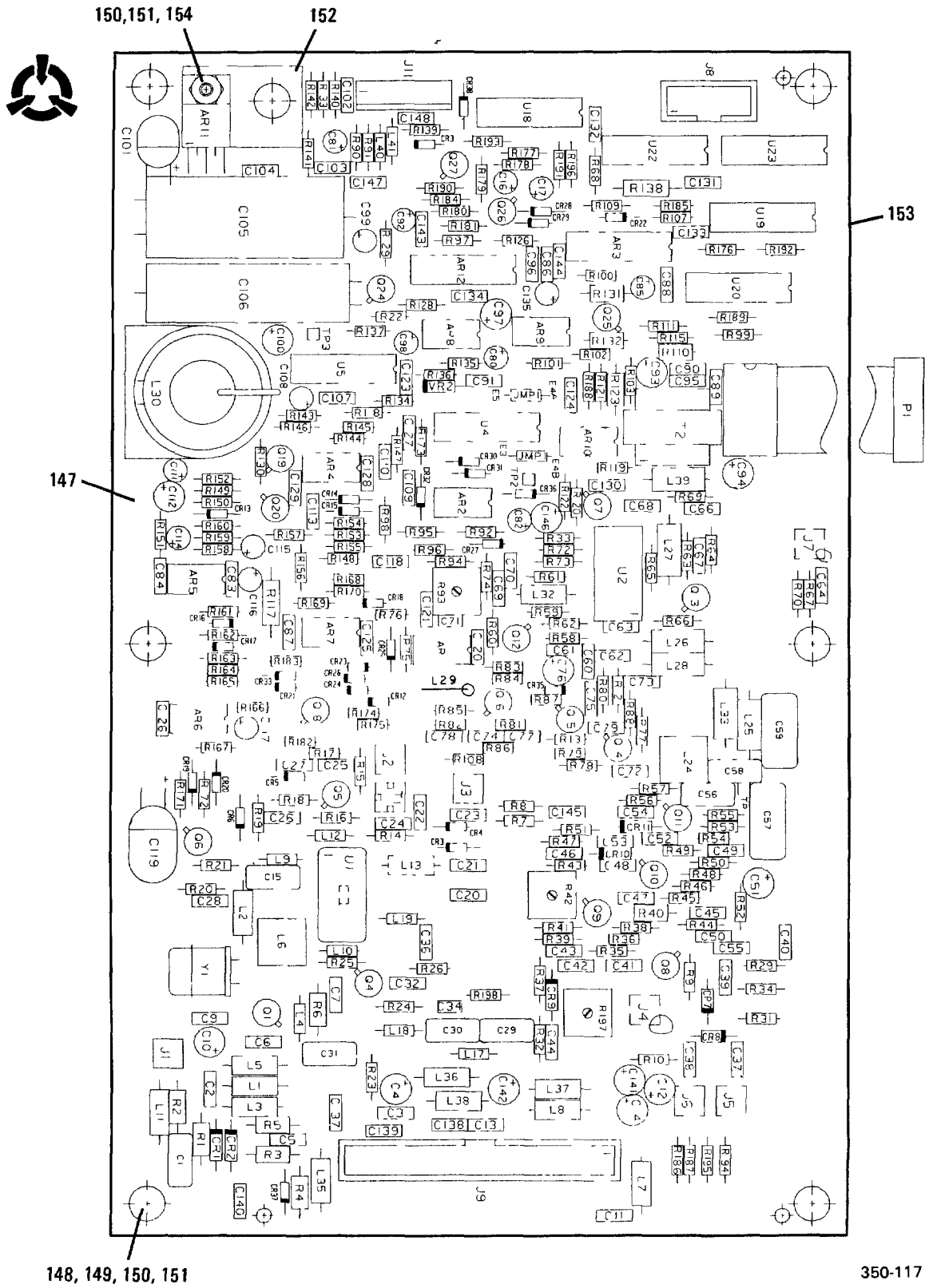

Figure 7-18. Receiver PWB Assy, A1A7



## NOTE

To find index numbers for circuit board components, use the reference designator index at the end of this chapter. The complete reference designator for a circuit board component consists of "1," followed by the assembly designator (A1A1, A1A2, etc.), then the reference designator on the illustration. For example, the complete reference designator for R25 on the Exciter PWB Assy is 1A1A1 R25.

Figure & Index Number	Part Number	FSCM	Description							Units Per Assy	Usable On Code	SMR Code
			1	2	3	4	5	6	7			
7-18-	10085-5200	14304	CIRCUIT CARD ASSY, A1A7							1		PAOLD
- 1	TL071MJG	01295	. MICROCIRCUIT							1		PADZZ
- 2	MC1558U	04713	. MICROCIRCUIT							8		PADZZ
- 3	SA571F	18324	. MICROCIRCUIT							2		PADZZ
- 4	TDA2002H	04713	. MICROCIRCUIT							1		PADZZ
- 5	CM05ED270G03	81349	. CAP FXD MICA							1		PADZZ
- 6	CK06BX103K	81349	. CAPACITOR, FXD, CER							17		PADZZ
- 7	T392C106M025AS	31433	. CAP, FXD, ELCTLT							15		PADZZ
- 8	DR10DB689J	93958	. CAPACITOR, FXD, CER							1		PADZZ
- 9	CM05FD910G03	81349	. CAP, FXD MICA							1		PADZZ
- 10	T392B225K025AS	31433	. CAP FXD ELECTLT							2		PADZZ
- 11	T392B225M025AS	31433	. CAP FXD ELECTLT							2		PADZZ
- 12	C13-0103-102	14304	. CAP FXD MICA							1		PADZZ
- 13	CK05BX101K	81349	. CAPACITOR, FXD, CER							1		PADZZ
- 14	CK06BX474K	81349	. CAPACITOR, FXD, CER							34		PADZZ
- 15	CK06BX104K	81349	. CAPACITOR, FXD, CER							28		PADZZ
- 16	CMR05E510G0DR	81349	. CAPACITOR, FXD, MICA							1		PADZZ
- 17	CM05ED560G03	81349	. CAPACITOR, FXD, MICA							1		PADZZ
- 18	CMR05E360G0DR	81349	. CAPACITOR, FXD, MICA							1		PADZZ
- 19	CMR05E220J0DR	81349	. CAPACITOR, FXD, MICA							1		PADZZ
- 20	CK05BX102K	81349	. CAPACITOR, FXD, CER							4		PADZZ
- 21	CK06BX223K	81349	. CAPACITOR, FXD, CER							2		PADZZ
- 22	CM05FD181G03	81349	. CAPACITOR, FXD, MICA							1		PADZZ
- 23	CMR06F112G0DR	81349	. CAPACITOR, FXD, MICA							1		PADZZ
- 24	CM05ED680G03	81349	. CAP, FXD MICA							1		PADZZ
- 25	CMR06F122G0DR	81349	. CAPACITOR, FXD, MICA							1		PADZZ
- 26	M39014/02-1331	81349	. CAPACITOR, FXD, CER							1		PADZZ
- 27	M39014/02-1322	81349	. CAPACITOR, FXD, CER							1		PADZZ
- 28	CK06BX224K	81349	. CAPACITOR, FXD, CER							3		PADZZ
- 29	M39014/02-1329	81349	. CAPACITOR, FXD, CER							1		PADZZ
- 30	T392B335M025AS	31433	. CAP, FXD, ELCTLT							8		PADZZ
- 31	T392C335M035AS	31433	. CAP, FXD, ELCTLT							3		PADZZ
- 32	T392B155M035AS	31433	. CAP, FXD, ELCTLT							2		PADZZ
- 33	T392F157M016AS	31433	. CAP, FXD ELECTLT							1		PADZZ
- 34	M39014/02-1354	81349	. CAPACITOR, FXD, CER							1		PADZZ
- 35	672D128H025FV5J	56289	. CAP, FXD, ELCTLT							1		PADZZ
- 36	672D477H025DS5J	56289	. CAPACITOR, FXD, ALUM							1		PADZZ
- 37	CDT. 22-35	31433	. CAP, FXD, ELCTLT							3		PADZZ
- 38	TAPF10K50	61725	. CAP, FXD, ELCTLT							1		PADZZ
- 39	CK05BX221K	81349	. CAPACITOR, FXD, CER							2		PADZZ
- 40	CK06BX222K	81349	. CAPACITOR, FXD, CER							1		PADZZ
- 41	UM9301	15969	. SEMICOND DEVICE, DIO							5		PADZZ
- 42	5082-3168	98734	. SEMICOND DEVICE, DIO							4		PADZZ
- 43	JAN1N4454	81349	. SEMICOND DEVICE, DIO							29		PADZZ
- 44	J-0031	14304	. CONNECTOR, PLUG, ELEC							5		PADZZ

Figure & Index Number	Part Number	FSCM	Description							Units Per Assy	Usable On Code	SMR Code
			1	2	3	4	5	6	7			
- 45	CA3028S	02735	.	.	.	.	.	.	.	5		PADZZ
- 46	11-0050-00C	58167	.	.	.	.	.	.	.	2		PADZZ
- 47	609-1027	15912	.	.	.	.	.	.	.	1		PADZZ
- 48	500-4027-E	59730	.	.	.	.	.	.	.	1		PADZZ
- 49	22-11-2082	27264	.	.	.	.	.	.	.	1		PADZZ
- 50	MP-1142	14304	.	.	.	.	.	.	.	1		PADZZ
- 51	MS14046-8	96906	.	.	.	.	.	.	.	4		PADZZ
- 52	MS18130-2	96906	.	.	.	.	.	.	.	1		PADZZ
- 53	MS75084-16	96906	.	.	.	.	.	.	.	1		PADZZ
- 54	8966	81564	.	.	.	.	.	.	.	1		PADZZ
- 55	MS14046-1	96906	.	.	.	.	.	.	.	5		PADZZ
- 56	MS75083-1	96906	.	.	.	.	.	.	.	2		PADZZ
- 57	MS75083-6	96906	.	.	.	.	.	.	.	1		PADZZ
- 58	MS18130-5	96906	.	.	.	.	.	.	.	1		PADZZ
- 59	2743002122	34899	.	.	.	.	.	.	.	1		PADZZ
- 60	MS75083-7	96906	.	.	.	.	.	.	.	2		PADZZ
- 61	MS75083-10	96906	.	.	.	.	.	.	.	1		PADZZ
- 62	9200	81564	.	.	.	.	.	.	.	1		PADZZ
- 63	LT10K227	81349	.	.	.	.	.	.	.	1		PADZZ
- 64	MS90539-3	96906	.	.	.	.	.	.	.	4		PADZZ
- 65	MS75089-10	96906	.	.	.	.	.	.	.	1		PADZZ
- 66	MS75089-13	96906	.	.	.	.	.	.	.	1		PADZZ
- 67	10085-5212	14304	.	.	.	.	.	.	.	1		PADZZ
- 68	MS90538-3	96906	.	.	.	.	.	.	.	1		PADZZ
- 69	MS75087-7	96906	.	.	.	.	.	.	.	2		PADZZ
- 70	10085-0327	14304	.	.	.	.	.	.	.	1		PAOZZ
- 71	U310	04713	.	.	.	.	.	.	.	2		PADZZ
- 72	JAN2N2369A	81349	.	.	.	.	.	.	.	1		PADZZ
- 73	JAN2N2222A	81349	.	.	.	.	.	.	.	13		PADZZ
- 74	3N187	80131	.	.	.	.	.	.	.	1		PADZZ
- 75	JAN2N4091	81349	.	.	.	.	.	.	.	2		PADZZ
- 76	JAN2N2907A	81349	.	.	.	.	.	.	.	1		PADZZ
- 77	2N4392	80131	.	.	.	.	.	.	.	1		PADZZ
- 78	RN55D27R4F	81349	.	.	.	.	.	.	.	1		PADZZ
- 79	RN55D1821F	81349	.	.	.	.	.	.	.	1		PADZZ
- 80	RN55D6980F	81349	.	.	.	.	.	.	.	1		PADZZ
- 81	RN55D2431F	81349	.	.	.	.	.	.	.	1		PADZZ
- 82	RN55D3010F	81349	.	.	.	.	.	.	.	1		PADZZ
- 83	RNC55K1820FS	81349	.	.	.	.	.	.	.	1		PADZZ
- 84	CF07-122J	78488	.	.	.	.	.	.	.	10		PADZZ
- 85	CF07-183J	78488	.	.	.	.	.	.	.	2		PADZZ
- 86	CF07-153J	78488	.	.	.	.	.	.	.	3		PADZZ
- 87	CF07-103J	78488	.	.	.	.	.	.	.	35		PADZZ
- 88	CF07-472J	78488	.	.	.	.	.	.	.	8		PADZZ
- 89	CF07-561J	78488	.	.	.	.	.	.	.	10		PADZZ
- 90	CF07-150J	78488	.	.	.	.	.	.	.	1		PADZZ
- 91	CF07-471J	78488	.	.	.	.	.	.	.	7		PADZZ
- 92	CF07-182J	78488	.	.	.	.	.	.	.	1		PADZZ
- 93	CF07-221J	78488	.	.	.	.	.	.	.	5		PADZZ
- 94	CF07-680J	78488	.	.	.	.	.	.	.	2		PADZZ
- 95	CF07-181J	78488	.	.	.	.	.	.	.	5		PADZZ

Figure & Index Number	Part Number	FSCM	Description							Units Per Assy	Usable On Code	SMR Code
			1	2	3	4	5	6	7			
- 96	CF07-473J	78488	.	.	.	.	.	.	.	9		PADZZ
- 97	CF07-101J	78488	.	.	.	.	.	.	.	7		PADZZ
- 98	RNC55K4750FS	81349	.	.	.	.	.	.	.	1		PADZZ
- 99	CF07-220J	78488	.	.	.	.	.	.	.	3		PADZZ
-100	63M501	02111	.	.	.	.	.	.	.	1		PADZZ
-101	CF07-152J	78488	.	.	.	.	.	.	.	3		PADZZ
-102	CF07-391J	78488	.	.	.	.	.	.	.	1		PADZZ
-103	CF07-562J	78488	.	.	.	.	.	.	.	1		PADZZ
-104	CF07-222J	78488	.	.	.	.	.	.	.	4		PADZZ
-105	CF07-470J	78488	.	.	.	.	.	.	.	2		PADZZ
-106	CF07-123J	78488	.	.	.	.	.	.	.	2		PADZZ
-107	CF07-102J	78488	.	.	.	.	.	.	.	8		PADZZ
-108	CF07-271J	78488	.	.	.	.	.	.	.	1		PADZZ
-109	CF07-223J	78488	.	.	.	.	.	.	.	3		PADZZ
-110	CF07-821J	78488	.	.	.	.	.	.	.	3		PADZZ
-111	CF07-100J	78488	.	.	.	.	.	.	.	1		PADZZ
-112	CF07-2R7J	78488	.	.	.	.	.	.	.	3		PADZZ
-113	3386F-1-503	32997	.	.	.	.	.	.	.	1		PADZZ
-114	CF07-682J	78488	.	.	.	.	.	.	.	1		PADZZ
-115	CF07-104J	78488	.	.	.	.	.	.	.	8		PADZZ
-116	CF07-683J	78488	.	.	.	.	.	.	.	1		PADZZ
-117	CF07-332J	78488	.	.	.	.	.	.	.	1		PADZZ
-118	RN55D6040F	81349	.	.	.	.	.	.	.	2		PADZZ
-119	ERD50TJ221	54473	.	.	.	.	.	.	.	1		PADZZ
-120	CF07-184J	78488	.	.	.	.	.	.	.	1		PADZZ
-121	CF07-331J	78488	.	.	.	.	.	.	.	1		PADZZ
-122	CF07-681J	78488	.	.	.	.	.	.	.	1		PADZZ
-123	CF07-154J	78488	.	.	.	.	.	.	.	1		PADZZ
-124	RN55D1002F	81349	.	.	.	.	.	.	.	2		PADZZ
-125	CF07-822J	78488	.	.	.	.	.	.	.	2		PADZZ
-126	ERD50TJ101	54473	.	.	.	.	.	.	.	1		PADZZ
-127	CF07-272J	78488	.	.	.	.	.	.	.	1		PADZZ
-128	CF07-124J	78488	.	.	.	.	.	.	.	1		PADZZ
-129	CF07-334J	78488	.	.	.	.	.	.	.	1		PADZZ
-130	CF07-273J	78488	.	.	.	.	.	.	.	1		PADZZ
-131	CF07-105J	78488	.	.	.	.	.	.	.	1		PADZZ
-132	CF07-393J	78488	.	.	.	.	.	.	.	4		PADZZ
-133	CF07-270J	78488	.	.	.	.	.	.	.	1		PADZZ
-134	CF07-224J	78488	.	.	.	.	.	.	.	1		PADZZ
-135	3386F-1-202	32997	.	.	.	.	.	.	.	1		PADZZ
-136	10085-5012	14304	.	.	.	.	.	.	.	1		PADZZ
-137	T2106	16741	.	.	.	.	.	.	.	1		PADZZ
-138	65499-101	22526	.	.	.	.	.	.	.	3		PADZZ
-139	SBL-1	15542	.	.	.	.	.	.	.	2		PADZZ
-140	CD4053BF	02735	.	.	.	.	.	.	.	2		PADZZ
-141	CD4094BF	02735	.	.	.	.	.	.	.	2		PADZZ
-142	CD4021BF	02735	.	.	.	.	.	.	.	1		PADZZ
-143	SN54LS368AJ	01295	.	.	.	.	.	.	.	1		PADZZ
-144	SN54LS138J	01295	.	.	.	.	.	.	.	1		PADZZ
-145	JAN1N750A	81349	.	.	.	.	.	.	.	1		PADZZ
-146	10085-5425	14304	.	.	.	.	.	.	.	1		PADZZ

Figure & Index Number	Part Number	FSCM	Description 1 2 3 4 5 6 7	Units	Usable	SMR Code
				Per Assy	On Code	
-147	10085-5209	14304	. CIRCUIT CARD	1		XA
-148	6611-0135	14304	. RETAINER, SCREW	7		PADZZ
-149	10085-5156	14304	. BUSHING	6		PADZZ
-150	MS51957-17	96906	. SCREW, MACHINE (AP)	8		PADZZ
-151	MS35338-135	96906	. WASHER, SPLIT (AP)	8		PADZZ
-152	10085-5155	14304	. BRKT, HEATSINK	1		XB
-153	10085-5164	14304	. COVER, RCVR	1		XB
-154	MS35649-244	96906	. NUT, PLAIN, HEX	1		PAOZZ



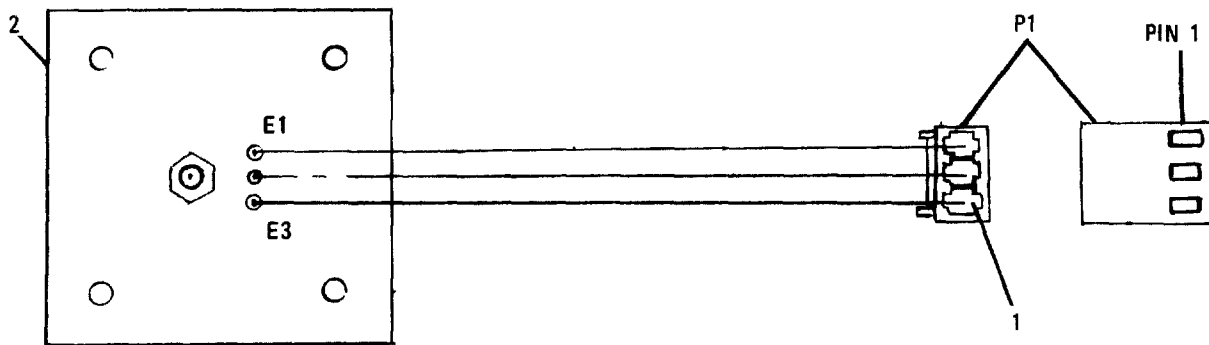

350-118

Figure 7-19. Crystal Oscillator Assy, A1A8

## NOTE

To find index numbers for circuit board components, use the reference designator index at the end of this chapter. The complete reference designator for a circuit board component consists of "1," followed by the assembly designator (A1A1, A1A2, etc.), then the reference designator on the illustration. For example, the complete reference designator for R25 on the Exciter PWB Assy is 1A1A1 R25.

Figure & Index Number	Part Number	FSCM	Description							Units Per Assy	Usable On Code	SMR Code												
			1	2	3	4	5	6	7															
7-19-	10085-0610	14304	O	S	C	I	L	L	A	T	O	R	A	S	S	R	F	A	1	A	8	1	PAOZZ	
- 1	08-56-0110	27264	.	C	O	N	N	E	C	T	O	R	,	P	L	U	G	,	E	L	E	C	3	PAOZZ
- 2	10085-0611	14304	.	O	S	C	I	L	L	A	T	O	R									1	XA	
- 3	22-01-3037	27264	.	C	O	N	N	E	C	T	O	R	,	P	L	U	G	,	E	L	E	C	1	PADZZ

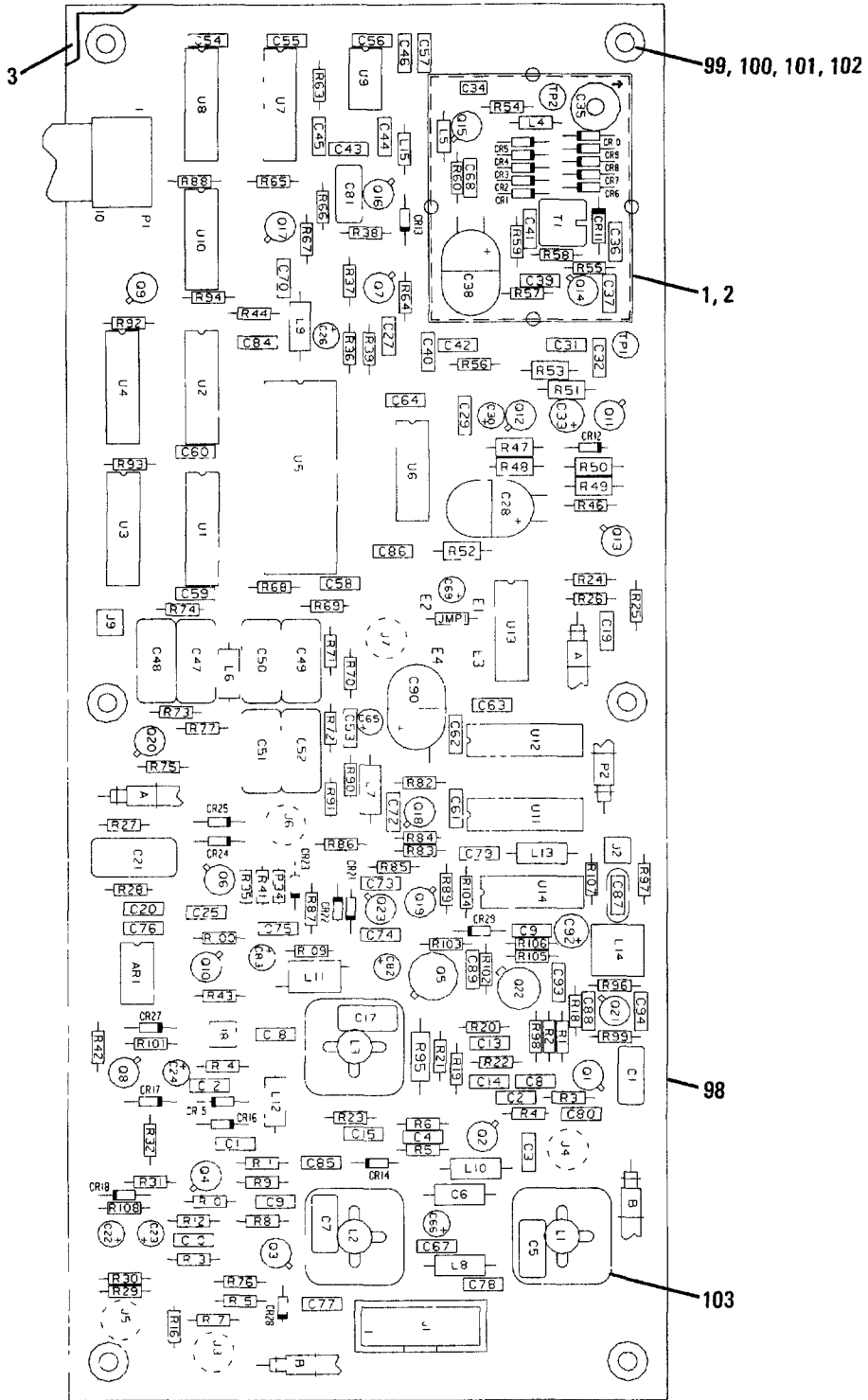

350-119

Figure 7-20. Reference/BFO PWB Assy, A1A9



## NOTE

To find index numbers for circuit board components, use the reference designator index at the end of this chapter. The complete reference designator for a circuit board component consists of "1," followed by the assembly designator (A1A1, A1A2, etc.), then the reference designator on the illustration. For example, the complete reference designator for R25 on the Exciter PWB Assy is 1A1A1 R25.

Figure & Index Number	Part Number	FSCM	Description							Units Per Assy	Usable On Code	SMR Code
			1	2	3	4	5	6	7			
7-20-	10085-5500	14304	CIRCUIT CARD ASSY,A1A9							1		PAODD
- 1	10085-5127	14304	. COVER,VCO							1		XB
- 2	10085-5128	14304	. COVER,SHIELD							1		XB
- 3	10085-5162	14304	. COVER,REF/BFO							1		XB
- 4	MC1558U	04713	. MICROCIRCUIT							1		PADZZ
- 5	CM05CD050D03	81349	. CAPACITOR,FXD,MICA							1		PADZZ
- 6	CK06BX103K	81349	. CAPACITOR,FXD,CER							19		PADZZ
- 7	CM05ED560G03	81349	. CAPACITOR,FXD,MICA							1		PADZZ
- 8	C12-0001-003	14304	. CAPACITOR,FXD,CER							1		PADZZ
- 9	CM05ED510G03	81349	. CAPACITOR,FXD,MICA							1		PADZZ
- 10	CK06BX104K	81349	. CAPACITOR,FXD,CER							33		PADZZ
- 11	M39014/02-1352	81349	. CAPACITOR,FXD,CER							1		PADZZ
- 12	CK06BX683K	81349	. CAPACITOR,FXD,CER							2		PADZZ
- 13	CMR06F621GODR	81349	. CAPACITOR,FXD,MICA							1		PADZZ
- 14	T392B335M025AS	31433	. CAP,FXD,ELCTLT							6		PADZZ
- 15	T392F686M025AS	31433	. CAP,FXD,ELCTLT							3		PADZZ
- 16	T392C106M025AS	31433	. CAP,FXD,ELCTLT							2		PADZZ
- 17	M39014/02-1358	81349	. CAPACITOR,FXD,CER							1		PADZZ
- 18	CK05BX102K	81349	. CAPACITOR,FXD,CER							2		PADZZ
- 19	CV31D350	81349	. CAPACITOR,VARIABLE							1		PADZZ
- 20	CD19FC562J03	14655	. CAPACITOR,FXD,MICA							2		PADZZ
- 21	CMR06F272GODP	81349	. CAPACITOR,FXD,MICA							2		PADZZ
- 22	CM06FD821J03	81349	. CAPACITOR,FXD,MICA							1		PADZZ
- 23	CMR06F751GODR	81349	. CAPACITOR,FXD,MICA							1		PADZZ
- 24	CM06FD272J03	81349	. CAPACITOR,FXD,MICA							2		PADZZ
- 25	T392B106M010AS	31433	. CAP,FXD,ELCTLT							3		PADZZ
- 26	CM05FD221G03	81349	. CAPACITOR,FXD,MICA							1		PADZZ
- 27	T392C226M010AS	31433	. CAP,FXD,ELECTLT							1		PADZZ
- 28	616532-901	37695	. SEMICOND DEVICE,DIO							10		PADZZ
- 29	MV-309	04713	. SEMICOND DEVICE,DIO							10		PADZZ
- 30	JAN1N3064	81349	. SEMICOND DEVICE,DIO							4		PADZZ
- 31	JAN1N5711	81349	. SEMICOND DEVICE,DIO							2		PADZZ
- 32	JAN1N4454	81349	. SEMICOND DEVICE,DIO							10		PADZZ
- 33	609-1427	59730	. CONNECTOR,RCPT,ELEC							1		PADZZ
- 34	700-209-NP	50173	. CONNECTOR,PLUG,ELEC							2		PADZZ
- 35	11-1050-00C	77264	. CONNECTOR,PLUG,ELEC							5		PADZZ
- 36	MP-1142	14304	. JUMPER,ELEC							1		PADZZ
- 37	L-0256	14304	. COIL,RF							1		PADZZ
- 38	10085-5506	14304	. COIL,RF							1		PADZZ
- 39	MS75084-10	96906	. COIL,RF							1		PADZZ
- 40	MS75084-3	96906	. COIL,RF							1		PADZZ
- 41	MS14046-7	96906	. COIL,RF							1		PADZZ
- 42	MS14046-1	96906	. COIL,RF							3		PADZZ
- 43	MS14046-8	96906	. COIL,RF							3		PADZZ
- 44	MS14046-6	96906	. COIL,RF							1		PADZZ

Figure & Index Number	Part Number	FSCM	Description							Units Per Assy	Usable On Code	SMR Code									
			1	2	3	4	5	6	7												
- 45	10085-0328	14304	.	C	A	B	L	E	A	S	S	Y	1		PAOZZ						
- 46	10085-0303	14304	.	C	A	B	L	E	A	S	S	Y	1		MOO						
- 47	JAN2N2369A	81349	.	T	R	A	N	S	I	S	T	O	2		PADZZ						
- 48	JAN2N2857	81349	.	T	R	A	N	S	I	S	T	O	1		PADZZ						
- 49	U310	04713	.	T	R	A	N	S	I	S	T	O	5		PADZZ						
- 50	JAN2N2907A	81349	.	T	R	A	N	S	I	S	T	O	6		PADZZ						
- 51	JAN2N2222A	81349	.	T	R	A	N	S	I	S	T	O	6		PADZZ						
- 52	MD918A	04713	.	T	R	A	N	S	I	S	T	O	1		PADZZ						
- 53	CF07-472J	78488	.	R	E	S	I	S	T	O	R	, F	X	D	, C	O	M	P	9		PADZZ
- 54	CF07-103J	78488	.	R	E	S	I	S	T	O	R	, F	X	D	, C	O	M	P	17		PADZZ
- 55	CF07-391J	78488	.	R	E	S	I	S	T	O	R	, F	X	D	, C	O	M	P	1		PADZZ
- 56	CF07-683J	78488	.	R	E	S	I	S	T	O	R	, F	X	D	, C	O	M	P	1		PADZZ
- 57	CF07-102J	78488	.	R	E	S	I	S	T	O	R	, F	X	D	, C	O	M	P	7		PADZZ
- 58	CF07-101J	78488	.	R	E	S	I	S	T	O	R	, F	X	D	, C	O	M	P	5		PADZZ
- 59	CF07-471J	78488	.	R	E	S	I	S	T	O	R	, F	X	D	, C	O	M	P	5		PADZZ
- 60	CF07-561J	78488	.	R	E	S	I	S	T	O	R	, F	X	D	, C	O	M	P	2		PADZZ
- 61	CF07-3R3J	78488	.	R	E	S	I	S	T	O	R	, F	X	D	, C	O	M	P	1		PADZZ
- 62	CF07-473J	78488	.	R	E	S	I	S	T	O	R	, F	X	D	, C	O	M	P	4		PADZZ
- 63	CF07-180J	78488	.	R	E	S	I	S	T	O	R	, F	X	D	, C	O	M	P	5		PADZZ
- 64	CF07-104J	78488	.	R	E	S	I	S	T	O	R	, F	X	D	, C	O	M	P	5		PADZZ
- 65	CF07-680J	78488	.	R	E	S	I	S	T	O	R	, F	X	D	, C	O	M	P	2		PADZZ
- 66	CF07-121J	78488	.	R	E	S	I	S	T	O	R	, F	X	D	, C	O	M	P	1		PADZZ
- 67	CF07-223J	78488	.	R	E	S	I	S	T	O	R	, F	X	D	, C	O	M	P	2		PADZZ
- 68	RNC55K6810FS	81349	.	R	E	S	I	S	T	O	R	, F	X	D	, F	I	L	M	4		PADZZ
- 69	RN55D6810F	81349	.	R	E	S	I	S	T	O	R	, F	X	D	, F	I	L	M	4		PADZZ
- 70	RNC55K9091FS	81349	.	R	E	S	I	S	T	O	R	, F	X	D	, F	I	L	M	1		PADZZ
- 71	RN55D3321F	81349	.	R	E	S	I	S	T	O	R	, F	X	D	, F	I	L	M	1		PADZZ
- 72	RN55D5901F	81349	.	R	E	S	I	S	T	O	R	, F	X	D	, F	I	L	M	1		PADZZ
- 73	CF07-513J	78488	.	R	E	S	I	S	T	O	R	, F	X	D	, C	O	M	P	1		PADZZ
- 74	CF07-470J	78488	.	R	E	S	I	S	T	O	R	, F	X	D	, C	O	M	P	1		PADZZ
- 75	CF07-270J	78488	.	R	E	S	I	S	T	O	R	, F	X	D	, C	O	M	P	2		PADZZ
- 76	CF07-221J	78488	.	R	E	S	I	S	T	O	R	, F	X	D	, C	O	M	P	3		PADZZ
- 77	CF07-201J	78488	.	R	E	S	I	S	T	O	R	, F	X	D	, C	O	M	P	1		PADZZ
- 78	CF07-272J	78488	.	R	E	S	I	S	T	O	R	, F	X	D	, C	O	M	P	2		PADZZ
- 79	CF07-510J	78488	.	R	E	S	I	S	T	O	R	, F	X	D	, C	O	M	P	2		PADZZ
- 80	CF07-330J	78488	.	R	E	S	I	S	T	O	R	, F	X	D	, C	O	M	P	1		PADZZ
- 81	CF07-150J	78488	.	R	E	S	I	S	T	O	R	, F	X	D	, C	O	M	P	1		PADZZ
- 82	CF07-160J	78488	.	R	E	S	I	S	T	O	R	, F	X	D	, C	O	M	P	1		PADZZ
- 83	CF07-562J	78488	.	R	E	S	I	S	T	O	R	, F	X	D	, C	O	M	P	1		PADZZ
- 84	CF07-331J	78488	.	R	E	S	I	S	T	O	R	, F	X	D	, C	O	M	P	1		PADZZ
- 85	CF07-823J	78488	.	R	E	S	I	S	T	O	R	, F	X	D	, C	O	M	P	1		PADZZ
- 86	10073-7003	14304	.	T	R	A	N	S	I	S	T	O	R						1		PADZZ
- 87	105-0858-001	74970	.	J	A	C	K	, T	I	P								1		PADZZ	
- 88	105-0852-001	74970	.	J	A	C	K	, T	I	P								1		PADZZ	
- 89	CD4094BF	02735	.	M	I	C	R	O	C	I	R	C	I	T				4		PADZZ	
- 90	MC145152L	04713	.	M	I	C	R	O	C	I	R	C	I	T				1		PADZZ	
- 91	SN54LS00J	01295	.	M	I	C	R	O	C	I	R	C	I	T				2		PADZZ	
- 92	MC12013L	04713	.	M	I	C	R	O	C	I	R	C	I	T				1		PADZZ	
- 93	M38510/31505BEA	81349	.	M	I	C	R	O	C	I	R	C	I	T				1		PADZZ	
- 94	DS8629J-8	27014	.	M	I	C	R	O	C	I	R	C	I	T				1		PADZZ	
- 95	CD4011BF	02735	.	M	I	C	R	O	C	I	R	C	I	T				1		PADZZ	

Figure & Index Number	Part Number	FSCM	Description							Units Per Assy	Usable On Code	SMR Code
			1	2	3	4	5	6	7			
- 96	SN54LS390J	01295	.							2		PADZZ
- 97	M3850/30102BCB	81349	.							1		PADZZ
- 98	10085-5509	14304	.							1		XA
- 99	6611-0135	14304	.							6		PADZZ
-100	10085-5156	14304	.							6		PADZZ
-101	MS35338-135	96906	.							6		PADZZ
-102	MS51957-17	96906	.							6		PADZZ
-103	850-0038	14304	.							2		XB

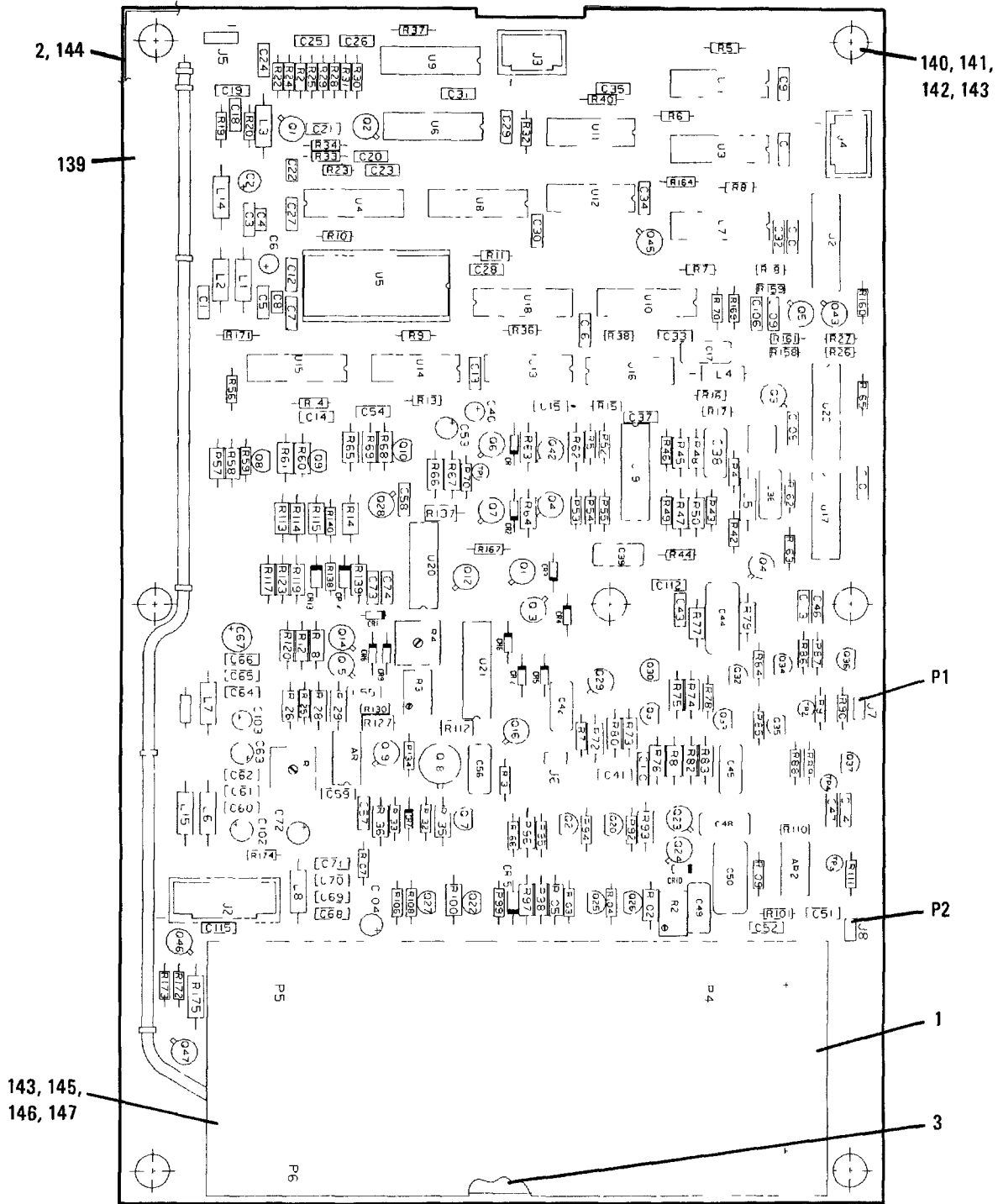

350-120

Figure 7-21. Synthesizer PWB Assy, A1A10

## NOTE

To find index numbers for circuit board components, use the reference designator index at the end of this chapter. The complete reference designator for a circuit board component consists of "1," followed by the assembly designator (A1A1, A1A2, etc.), then the reference designator on the illustration. For example, the complete reference designator for R25 on the Exciter PWB Assy is 1A1A1 R25.

Figure & Index Number	Part Number	FSCM	Description							Units Per Assy	Usable On Code	SMR Code
			1	2	3	4	5	6	7			
7-21-	10085-5600	14304	CIRCUIT CARD ASSY, A1A10							1		PAODD
- 1	10085-5126	14304	. COVER, VCO							1		XB
- 2	10085-5163	14304	. COVER, SYN							1		XB
- 3	10085-5640	14304	. CIRCUIT CARD ASSY, A1A10A1							1		XA
- 4	TL071MJG	01295	. MICROCIRCUIT							2		PADZZ
- 5	CK06BX104K	81349	. CAPACITOR, FXD, CER							42		PADZZ
- 6	T392C106M025AS	31433	. CAP, FXD, ELCTLT							6		PADZZ
- 7	CK05BX102K	81349	. CAPACITOR, FXD, CER							3		PADZZ
- 8	T392B106M010AS	31433	. CAP, FXD, ELCTLT							3		PADZZ
- 9	CM05ED560G03	81349	. CAPACITOR, FXD, MICA							4		PADZZ
- 10	CK06BX103K	81349	. CAPACITOR, FXD, CER							15		PADZZ
- 11	X440, .01, 107, 50	71785	. CAPACITOR, FXD, FILM							1		PADZZ
- 12	CM05FD151G03	81349	. CAPACITOR, FXD, MICA							1		PADZZ
- 13	CM06FD152J03	81349	. CAPACITOR, FXD, MICA							1		PADZZ
- 14	CM05CD180J03	81349	. CAPACITOR, FXD, MICA							1		PADZZ
- 15	CM05FD331G03	81349	. CAPACITOR, FXD, MICA							1		PADZZ
- 16	CM05CD100D03	81349	. CAPACITOR, FXD, MICA							2		PADZZ
- 17	CMR06F471G0DR	81349	. CAPACITOR, FXD, MICA							1		PADZZ
- 18	T392D686K010AS	31433	. CAP, FXD, ELCTLT							1		PADZZ
- 19	M39014/02-1419	81349	. CAPACITOR, FXD, CER							1		PADZZ
- 20	CK06BX474K	81349	. CAPACITOR, FXD, CER							3		PADZZ
- 21	JAN1N4454	81349	. SEMICOND DEVICE, DIO							8		PADZZ
- 22	JAN1N5711	81349	. SEMICOND DEVICE, DIO							4		PADZZ
- 23	JAN1N825	81349	. SEMICOND DEVICE, DIO							2		PADZZ
- 24	JAN1N748A	81349	. SEMICOND DEVICE, DIO							1		PADZZ
- 25	700-209-NP	50173	. CONNECTOR, PLUG, ELEC							1		PADZZ
- 26	609-1427	59730	. CONNECTOR, RCPT, ELEC							1		PADZZ
- 27	609-1027	15912	. CONNECTOR, RCPT, ELEC							2		PADZZ
- 28	51-407-116	99313	. CONNECTOR, PLUG, ELEC							1		PADZZ
- 29	22-03-2021	27264	. CONNECTOR, PLUG, ELEC							3		PADZZ
- 30	VK200-20/4B	02114	. COIL, RF							1		PADZZ
- 31	MS14046-8	96906	. COIL, RF							4		PADZZ
- 32	MS18130-11	96906	. COIL RF							1		PADZZ
- 33	57-342-5	18212	. FERRITE BEAD							2		PADZZ
- 34	MS14046-1	96906	. COIL, RF							2		PADZZ
- 35	65474-001	00779	. JUMPER, ELEC							3		PADZZ
- 36	22-03-2032	27264	. CONNECTOR, PLUG, ELEC							1		PADZZ
- 37	22-03-2022	27264	. CONNECTOR, PLUG, ELEC							2		PADZZ
- 38	U310	04713	. TRANSISTOR							1		PADZZ
- 39	JAN2N2857	81349	. TRANSISTOR							2		PADZZ
- 40	2N4208	80131	. TRANSISTOR							2		PADZZ
- 41	JAN2N2222A	81349	. TRANSISTOR							6		PADZZ
- 42	JAN2N4957	81349	. TRANSISTOR							3		PADZZ
- 43	PN4917	07263	. TRANSISTOR							9		PADZZ
- 44	U309	04713	. TRANSISTOR							2		PADZZ

Figure & Index Number	Part Number	FSCM	Description							Units Per Assy	Usable On Code	SMR Code
			1	2	3	4	5	6	7			
- 45	JAN2N5116	81349	.	TRANSISTOR						2		PADZZ
- 46	MD918A	04713	.	TRANSISTOR						1		PADZZ
- 47	MPS-H34	04713	.	TRANSISTOR						9		PADZZ
- 48	2N4393	80131	.	TRANSISTOR						2		PADZZ
- 49	2N5566	80131	.	TRANSISTOR						1		PADZZ
- 50	JAN2N2907A	81349	.	TRANSISTOR						2		PADZZ
- 51	JAN2N2369A	81349	.	TRANSISTOR						1		PADZZ
- 52	3386F-1-500	32997	.	RESISTOR, VARIABLE						1		PADZZ
- 53	3299W-1-202	57921	.	RESISTOR, VARIABLE						1		PADZZ
- 54	3299W-1-503	57921	.	RESISTOR, VARIABLE						1		PADZZ
- 55	3386F-1-102	32997	.	RESISTOR, VARIABLE						1		PADZZ
- 56	CF07-102J	78488	.	RESISTOR, FXD, COMP						19		PADZZ
- 57	CF07-103J	78488	.	RESISTOR, FXD, COMP						9		PADZZ
- 58	CF07-270J	78488	.	RESISTOR, FXD, COMP						3		PADZZ
- 59	CF07-680J	78488	.	RESISTOR, FXD, COMP						2		PADZZ
- 60	CF07-104J	78488	.	RESISTOR, FXD, COMP						3		PADZZ
- 61	CF07-470J	78488	.	RESISTOR, FXD, COMP						12		PADZZ
- 62	CF07-221J	78488	.	RESISTOR, FXD, COMP						2		PADZZ
- 63	CF07-563J	78488	.	RESISTOR, FXD, COMP						1		PADZZ
- 64	CF07-472J	78488	.	RESISTOR, FXD, COMP						6		PADZZ
- 65	CF07-560J	78488	.	RESISTOR, FXD, COMP						4		PADZZ
- 66	CF07-152J	78488	.	RESISTOR, FXD, COMP						1		PADZZ
- 67	CF07-100J	78488	.	RESISTOR, FXD, COMP						3		PADZZ
- 68	CF07-151J	78488	.	RESISTOR, FXD, COMP						1		PADZZ
- 69	RN55D6810F	81349	.	RESISTOR, FXD, FILM						4		PADZZ
- 70	RNC55K1331FS	81349	.	RESISTOR, FXD, FILM						2		PADZZ
- 71	RN55D1331F	81349	.	RESISTOR, FXD, FILM						2		PADZZ
- 72	CF07-471J	78488	.	RESISTOR, FXD, COMP						3		PADZZ
- 73	CF07-333J	78488	.	RESISTOR, FXD, COMP						1		PADZZ
- 74	CF07-182J	78488	.	RESISTOR, FXD, COMP						1		PADZZ
- 75	RNC55K1501FS	81349	.	RESISTOR, FXD, FILM						1		PADZZ
- 76	RN55D1212F	81349	.	RESISTOR, FXD, FILM						2		PADZZ
- 77	RNC55K1781FS	81349	.	RESISTOR, FXD, FILM						1		PADZZ
- 78	RNC55K8250FS	81349	.	RESISTOR, FXD, FILM						3		PADZZ
- 79	RNC55K1960FS	81349	.	RESISTOR, FXD, FILM						1		PADZZ
- 80	RN55D5111F	81349	.	RESISTOR, FXD, FILM						3		PADZZ
- 81	RNC55K3481FS	81349	.	RESISTOR, FXD, FILM						1		PADZZ
- 82	RNC55K6190FS	81349	.	RESISTOR, FXD, FILM						2		PADZZ
- 83	RN55D7501F	81349	.	RESISTOR, FXD, FILM						1		PADZZ
- 84	CF07-220J	78488	.	RESISTOR, FXD, XOMP						1		PADZZ
- 85	RN55D4422F	81349	.	RESISTOR, FXD, FILM						1		PADZZ
- 86	RNC55K1472FS	81349	.	RESISTOR, FXD, FILM						2		PADZZ
- 87	RN55D1000F	81349	.	RESISTOR, FXD, FILM						4		PADZZ
- 88	RNC55K1961FS	81349	.	RESISTOR, FXD, FILM						6		PADZZ
- 89	RN55D6190F	81349	.	RESISTOR, FXD, FILM						2		PADZZ
- 90	RNC55K2870FS	81349	.	RESISTOR, FXD, FILM						1		PADZZ
- 91	RN55D1472F	81349	.	RESISTOR, FXD, FILM						2		PADZZ
- 92	RNC55K2151FS	81349	.	RESISTOR, FXD, FILM						1		PADZZ
- 93	CF07-101J	78488	.	RESISTOR, FXD, COMP						8		PADZZ
- 94	CF07-332J	78488	.	RESISTOR, FXD, COMP						2		PADZZ
- 95	RN55D1961F	81349	.	RESISTOR, FXD, FILM						6		PADZZ

Figure & Index Number	Part Number	FSCM	Description							Units Per Assy	Usable On Code	SMR Code
			1	2	3	4	5	6	7			
- 96	RN55D8250F	81349	.	RESISTOR	,FXD	,FILM				3		PADZZ
- 97	RNC55K5110FS	81349	.	RESISTOR	,FXD	,FILM				2		PADZZ
- 98	RN55D5110F	81349	.	RESISTOR	,FXD	,FILM				2		PADZZ
- 99	RN55D6811F	81349	.	RESISTOR	,FXD	,FILM				3		PADZZ
-100	CF07-183J	78488	.	RESISTOR	,FXD	,COMP				1		PADZZ
-101	CF07-821J	78488	.	RESISTOR	,FXD	,COMP				2		PADZZ
-102	RN55D1002F	81349	.	RESISTOR	,FXD	,FILM				2		PADZZ
-103	RN55D1001F	81349	.	RESISTOR	,FXD	,FILM				3		PADZZ
-104	RNC55K3831FS	81349	.	RESISTOR	,FXD	,FILM				3		PADZZ
-105	RN55D3831F	81349	.	RESISTOR	,FXD	,FILM				3		PADZZ
-106	CF07-562J	78488	.	RESISTOR	,FXD	,COMP				1		PADZZ
-107	RN55D2001F	81349	.	RESISTOR	,FXD	,FILM				1		PADZZ
-108	RN55D9093F	81349	.	RESISTOR	,FXD	,FILM				1		PADZZ
-109	CF07-106J	78488	.	RESISTOR	,FXD	,COMP				1		PADZZ
-110	CF07-222J	78488	.	RESISTOR	,FXD	,COMP				2		PADZZ
-111	RNC55K4221FS	81349	.	RESISTOR	,FXD	,FILM				1		PADZZ
-112	RN55D1332F	81349	.	RESISTOR	,FXD	,FILM				1		PADZZ
-113	CF07-681J	78488	.	RESISTOR	,FXD	,COMP				1		PADZZ
-114	CF07-473J	78488	.	RESISTOR	,FXD	,COMP				3		PADZZ
-115	CF07-153J	78488	.	RESISTOR	,FXD	,COMP				1		PADZZ
-116	ERD50TJ102	54473	.	RESISTOR	,FXD	,COMP				1		PADZZ
-117	65499-101	22526	.	CONNECTOR	,PLUG	,ELEC				4		PADZZ
-118	SN54LS138J	01295	.	MICROCIRCUIT						1		PADZZ
-119	CD4021BF	02735	.	MICROCIRCUIT						1		PADZZ
-120	SN54LS368AJ	01295	.	MICROCIRCUIT						1		PADZZ
-121	MC12013L	04713	.	MICROCIRCUIT						1		PADZZ
-122	10085-5620	14304	.	MICROCIRCUIT						1		PADZZ
-123	CD4094BF	02735	.	MICROCIRCUIT						2		PADZZ
-124	SN54LS168AJ	01295	.	MICROCIRCUIT						1		PADZZ
-125	SN54LS192J	01295	.	MICROCIRCUIT						2		PADZZ
-126	M38510/00206BCB	81349	.	MICROCIRCUIT						1		PADZZ
-127	M38510/30301BCB	81349	.	MICROCIRCUIT						1		PADZZ
-128	M38510/30501BCB	81349	.	MICROCIRCUIT						1		PADZZ
-129	SN54LS74AJ	01295	.	MICROCIRCUIT						1		PADZZ
-130	M38510/30106BEB	81349	.	MICROCIRCUIT						1		PADZZ
-131	M38510/07101BCB	81349	.	MICROCIRCUIT						2		PADZZ
-132	SN54S74J	01295	.	MICROCIRCUIT						2		PADZZ
-133	SN54LS109AJ	01295	.	MICROCIRCUIT						1		PADZZ
-134	M38510/06101BEB	81349	.	MICROCIRCUIT						1		PADZZ
-135	FBT00-015	80103	.	SCD						1		PADZZ
-136	10085-5610	14304	.	MICROCIRCUIT						1		PADZZ
-137	CD4046BF	02735	.	MICROCIRCUIT						1		PADZZ
-138	524-AG11D	91506	.	SOCKET PLUG IN	ELEC					1		PADZZ
-139	10085-5609	14304	.	CIRCUIT CARD						1		XA
-140	6611-0135	14304	.	RETAINER	,SCREW					7		PADZZ
-141	10085-5156	14304	.	BUSHING						7		PADZZ
-142	MS51957-17	96906	.	SCREW	,MACHINE (AP)					7		PADZZ
-143	MS35338-135	96906	.	WASHER	,SPLIT (AP)					11		PADZZ
-144	10085-5113	14304	.	COVER						1		XB
-145	MS15795-803	96906	.	WASHER	,FLAT (AP)					4		PADZZ
-146	18092B-B0440-14	46384	.	SPACER						4		XB
-147	MS51957-13	96906	.	SCREW	,MACHINE (AP)					4		PADZZ

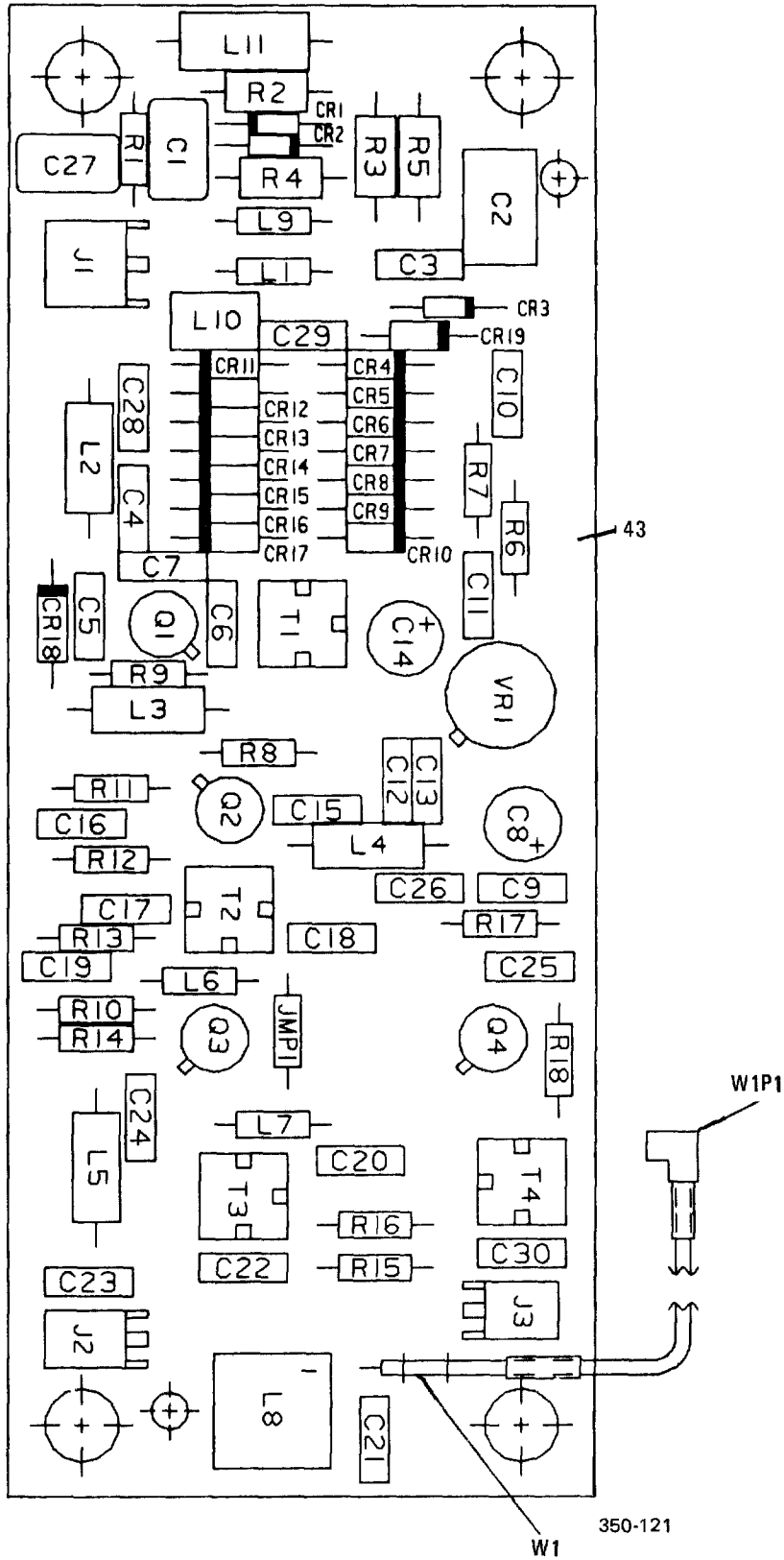

Figure 7-22. VCO PWB Assy, A1A10A1



## NOTE

To find index numbers for circuit board components, use the reference designator index at the end of this chapter. The complete reference designator for a circuit board component consists of "1," followed by the assembly designator (A1A1, A1A2, etc.), then the reference designator on the illustration. For example, the complete reference designator for R25 on the Exciter PWB Assy is 1A1A1 R25.

Figure & Index Number	Part Number	FSCM	Description 1 2 3 4 5 6 7	Units	Usable	SMR Code
				Per Assy	On Code	
7-22-	10085-5640	14304	CIRCUIT CARD ASSY,A1A10A1	1		XA
- 1	CM05FD101J03	81349	. CAP FXD MICA	1		PADZZ
- 2	C61-0002-003	14304	. CAPACITOR,FXD,FILM	1		PADZZ
- 3	CK05BX102K	81349	. CAPACITOR,FXD,CER	9		PADZZ
- 4	T392C106M025AS	31433	. CAP,FXD,ELCTLT	2		PADZZ
- 5	CK06BX104K	81349	. CAPACITOR,FXD,CER	4		PADZZ
- 6	CK06BX103K	81349	. CAPACITOR,FXD,CER	9		PADZZ
- 7	CK05BX101K	81349	. CAPACITOR,FXD,CER	2		PADZZ
- 8	CK05BX100K	81349	. CAPACITOR,FXD,CER	1		PADZZ
- 9	CM05FD331G03	81349	. CAPACITOR,FXD,MICA	1		PADZZ
- 10	JAN1N5711	81349	. SEMICOND DEVICE,DIO	3		PADZZ
- 11	MV-309	04713	. SEMICOND DEVICE,DIO	14		PADZZ
- 12	JAN1N3064	81349	. SEMICOND DEVICE,DIO	1		PADZZ
- 13	5082-3168	98734	. SEMICOND DEVICE,DIO	1		PADZZ
- 14	22-14-2034	27264	. CONNECTOR,RCPT,ELEC	1		PADZZ
- 15	22-14-2024	27264	. CONNECTOR,RCPT,ELEC	2		PADZZ
- 16	MP-1142	14304	. JUMPER,ELEC	1		PADZZ
- 17	MS75084-10	96906	. COIL,RF	2		PADZZ
- 18	MS14046-1	96906	. COIL,RF	4		PADZZ
- 19	MS75084-12	96906	. COIL,RF	1		PADZZ
- 20	MS75083-2	96906	. COIL RF	1		PADZZ
- 21	51-328-3850-910	98291	. COIL RF	1		PADZZ
- 22	10085-5612	14304	. COIL RF	1		PADZZ
- 23	MS75089-12	96906	. COIL,RF	1		PADZZ
- 24	U310	04713	. TRANSISTOR	4		PADZZ
- 25	CF07-560J	78488	. RESISTOR,FXD,COMP	1		PADZZ
- 26	RNC55K4990FS	81349	. RESISTOR,FXD,FILM	1		PADZZ
- 27	RN55D6811F	81349	. RESISTOR,FXD,FILM	1		PADZZ
- 28	RNC55K8451FS	81349	. RESISTOR FXD FILM	1		PADZZ
- 29	RN55D2210F	81349	. RESISTOR FXD FILM	1		PADZZ
- 30	CF07-101J	78488	. RESISTOR,FXD,COMP	2		PADZZ
- 31	CF07-470J	78488	. RESISTOR,FXD,COMP	2		PADZZ
- 32	CF07-563J	78488	. RESISTOR,FXD,COMP	1		PADZZ
- 33	CF07-100J	78488	. RESISTOR,FXD,COMP	1		PADZZ
- 34	CF07-151J	78488	. RESISTOR,FXD,COMP	2		PADZZ
- 35	CF07-153J	78488	. RESISTOR,FXD,COMP	1		PADZZ
- 36	CF07-273J	78488	. RESISTOR,FXD,COMP	1		PADZZ
- 37	CF07-391J	78488	. RESISTOR,FXD,COMP	1		PADZZ
- 38	CF07-271J	78488	. RESISTOR,FXD,COMP	1		PADZZ
- 39	10073-7002	14304	. TRANSFORMER,RF	1		PADZZ
- 40	10085-5611	14304	. TRANSFORMER,RF	1		PADZZ
- 41	10073-7014	14304	. TRANSFORMER,RF	2		PADZZ
- 42	M38510/10703BXC	81349	. MICROCIRCUIT	1		PADZZ
- 43	10085-5649	14304	. CIRCUIT CARD	1		XA

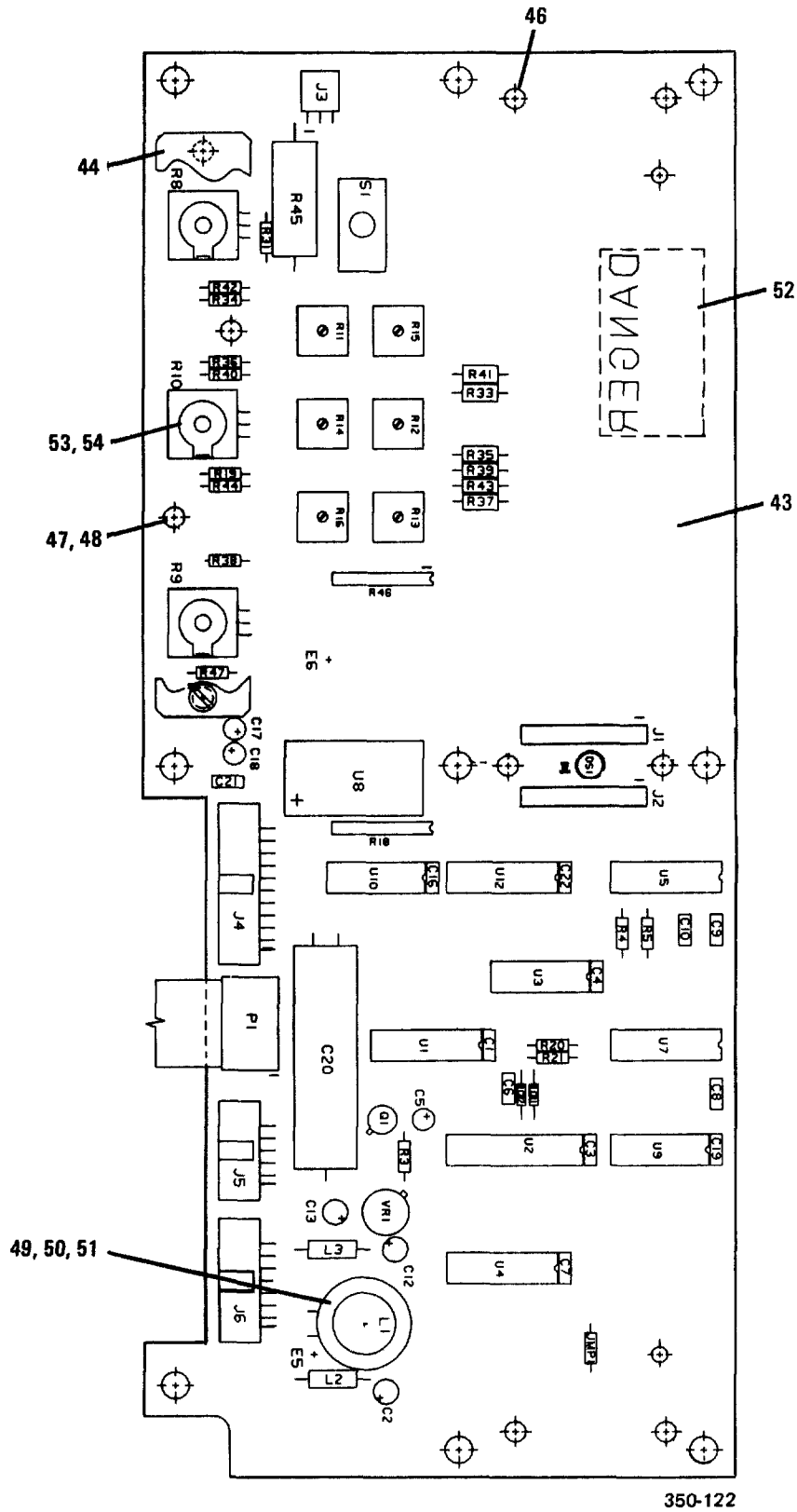

Figure 7-23. Front Panel PWB Assy, A1A11A1

## NOTE

To find index numbers for circuit board components, use the reference designator index at the end of this chapter. The complete reference designator for a circuit board component consists of "1," followed by the assembly designator (A1A1, A1A2, etc.), then the reference designator on the illustration. For example, the complete reference designator for R25 on the Exciter PWB Assy is 1A1A1 R25.

Figure & Index Number	Part Number	FSCM	Description							Units Per Assy	Usable On Code	SMR Code
			1	2	3	4	5	6	7			
7-23-	10085-2100	14304	CIRCUIT CARD ASSY,A1A11A1							1		PAODD
- 1	MDO15E104MAA	04222	. CAPACITOR, FXD, CER							12		PADZZ
- 2	T392B106M010AS	31433	. CAP, FXD, ELCTLT							1		PADZZ
- 3	199D225X9025BG2	56289	. CAP, FXD, ELCTLT							1		PADZZ
- 4	TAPF10M25	31433	. CAP, FXD, ELCTLT							2		PADZZ
- 5	T392B335M025AS	31433	. CAP, FXD, ELCTLT							2		PADZZ
- 6	672D477H025DS5J	56289	. CAPACITOR, FXD, ALUM							1		PADZZ
- 7	JAN1N4454	81349	. SEMICOND DEVICE, DIO							2		PADZZ
- 8	5082-4655	01295	. LED							1		PADZZ
- 9	87334-3	00779	. CONNECTOR, RCPT, ELEC							2		PADZZ
- 10	22-12-2034	27264	. CONNECTOR, RCPT, ELEC							1		PADZZ
- 11	1251-8273	28480	. CONNECTOR, RCPT, ELEC							1		PADZZ
- 12	609-1007	15912	. CONNECTOR, RCPT, ELEC							1		PADZZ
- 13	1251-8274	28480	. CONNECTOR, RCPT, ELEC							1		PADZZ
- 14	MP-1142	14304	. JUMPER, ELEC							8		PADZZ
- 15	10085-2144	14304	. COIL, RF							1		PADZZ
- 16	MS14046-6	96906	. COIL, RF							1		PADZZ
- 17	MS90538-20	96906	. COIL, RF							1		PADZZ
- 18	10085-2113	14304	. CABLE ASSY, RF							1		PADZZ
- 19	JAN2N2222A	81349	. TRANSISTOR							1		PADZZ
- 20	CF07-104J	78488	. RESISTOR, FXD, COMP							3		PADZZ
- 21	CF07-103J	78488	. RESISTOR, FXD, COMP							2		PADZZ
- 22	CF07-154J	78488	. RESISTOR, FXD, COMP							1		PADZZ
- 23	10085-2141	14304	. RESISTOR, VARIABLE							1		PADZZ
- 24	10085-2143	14304	. RESISTOR, VARIABLE							1		PADZZ
- 25	10085-2142	14304	. RESISTOR, VARIABLE							1		PADZZ
- 26	3386F-1-502	32997	. RESISTOR, VARIABLE							6		PADZZ
- 27	4308R-101-472	32997	. RESISTOR, NETWORK							1		PADZZ
- 28	CF07-101J	78488	. RESISTOR, FXD, COMP							1		PADZZ
- 29	RW74U6R49F	81349	. RESISTOR, FXD, WW							1		PADZZ
- 30	4308R-101-102	32997	. RESISTOR, NETWORK							1		PADZZ
- 31	7101SDV700E	95146	. SWITCH, TOGGLE							1		PADZZ
- 32	SN54LS138J	01295	. MICROCIRCUIT							1		PADZZ
- 33	804991-1	96214	. MICROCIRCUIT							1		PADZZ
- 34	SN54LS00J	01295	. MICROCIRCUIT							1		PADZZ
- 35	M38510/30608BEB	81349	. MICROCIRCUIT							1		PADZZ
- 36	7901401EB	14933	. MICROCIRCUIT							1		PADZZ
- 37	SN54LS367AJ	01295	. MICROCIRCUIT							1		PADZZ
- 38	E312-E0001	63312	. MICROCIRCUIT							1		PADZZ
- 39	SN54LS74AJ	01295	. MICROCIRCUIT							1		PADZZ
- 40	DM5416J	27014	. MICROCIRCUIT							1		PADZZ
- 41	CD4094BF	02735	. MICROCIRCUIT							1		PADZZ
- 42	UA78M12HM	07263	. MICROCIRCUIT							1		PADZZ
- 43	10085-2109	14304	. CIRCUIT CARD							1		XA
- 44	10085-2105	14304	. BRACKET, ANGLE							1		XB

Figure & Index Number	Part Number	FSCM	Description							Units Per Assy	Usable On Code	SMR Code
			1	2	3	4	5	6	7			
- 45	1010M	60963	.	SPACER						1		XB
- 46	18097B-B0440-14	46384	.	SPACER						10		XB
- 47	MS35338-135	96906	.	WASHER, SPLIT (AP)						4		PADZZ
- 48	MS51957-14	96906	.	SCREW, MACHINE (AP)						4		PADZZ
- 49	O10440B062	13764	.	SCREW, MACHINE, NYLON						1		PAOZZ
- 50	2813-03-16	80045	.	NUT PL HEXAGON						1		PAOZZ
- 51	2261-N116	06540	.	WASHER, FLAT, NYLON						2		PAOZZ
- 52	MP-0745	14304	.	LABEL						1		MDO
- 53	H-0963	14304	.	NUT PLAIN HEX						3		XB
- 54	MS35333-76	96906	.	WASHER LOCK						3		PAOZZ

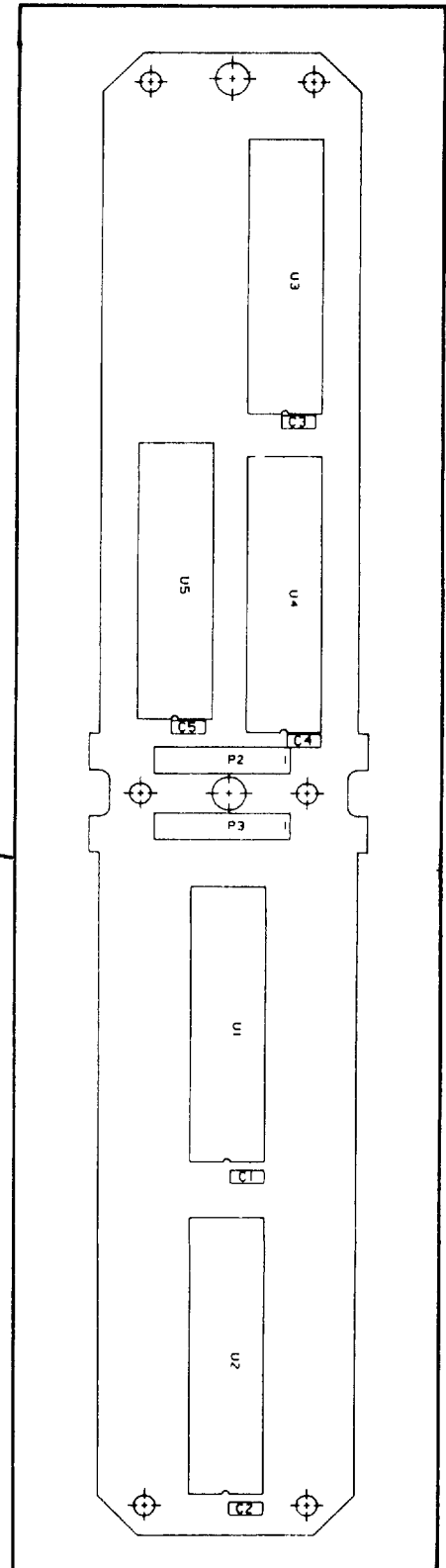
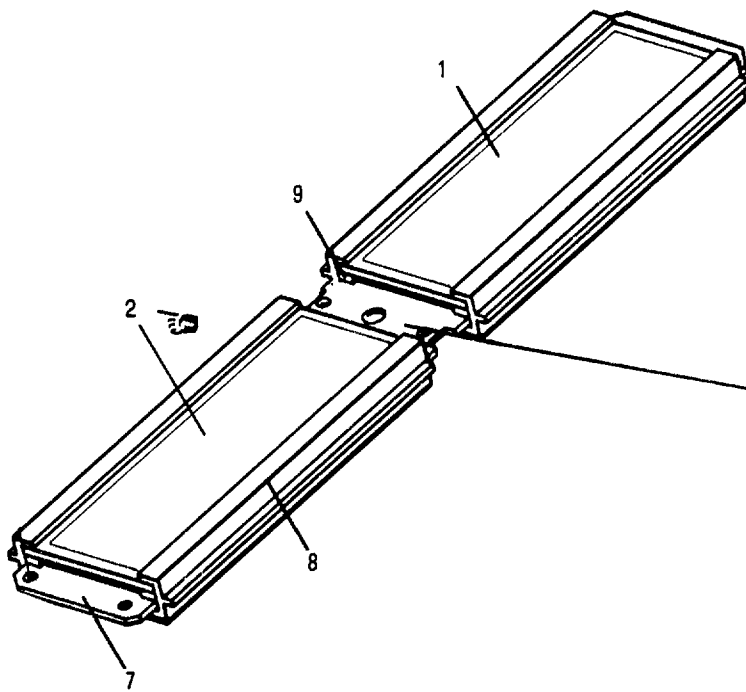

350-123

Figure 7-24. Display Assy, A1A11A2



## NOTE

To find Index numbers for circuit board components, use the reference designator index at the end of this chapter. The complete reference designator for a circuit board component consists of "1," followed by the assembly designator (A1A1, A1A2, etc.), then the reference designator on the illustration. For example, the complete reference designator for R25 on the Exciter PWB is 1A1A1 R25.

Figure & Index Number	Part Number	FSCM	Description 1 2 3 4 5 6 7	Units Per Assy	Usable On Code	SMR Code
7-24-	10085-2110	14304	DISPLAY ASSY, A1A11A2	1		PAODD
- 1	10085-2116	32890	. LCD, FREQUENCY	1		PADZZ
- 2	10085-2126	66670	. LCD, METER	1		PADZZ
- 3	10085-2120	14304	. CIRCUIT CARD ASSY	1		PAOLD
- 4	MD015E104MAA	04222	. CAPACITOR, FXD, CER	5		PADZZ
- 5	65516-110	22526	. CONTACT ASSY	2		PADZZ
- 6	HLCD0438AY	61587	. MICROCIRCUIT	5		PADZZ
- 7	10085-2129	14304	. CIRCUIT CARD	1		XA
- 8	10085-2112	14304	. BRACKET, RETAINER	2		XB
- 9	10085-5136	14304	. CONNECTOR, RCPT, ELEC	4		PADZZ
- 10	10085-2126	14304	. DISPLAY, BARGRAPH	1		PADZZ
- 11	10085-2116	14304	. DISPLAY, LCD	1		PADZZ
- 12	10085-2115	14304	. BACK, LIGHT	2		PADZZ

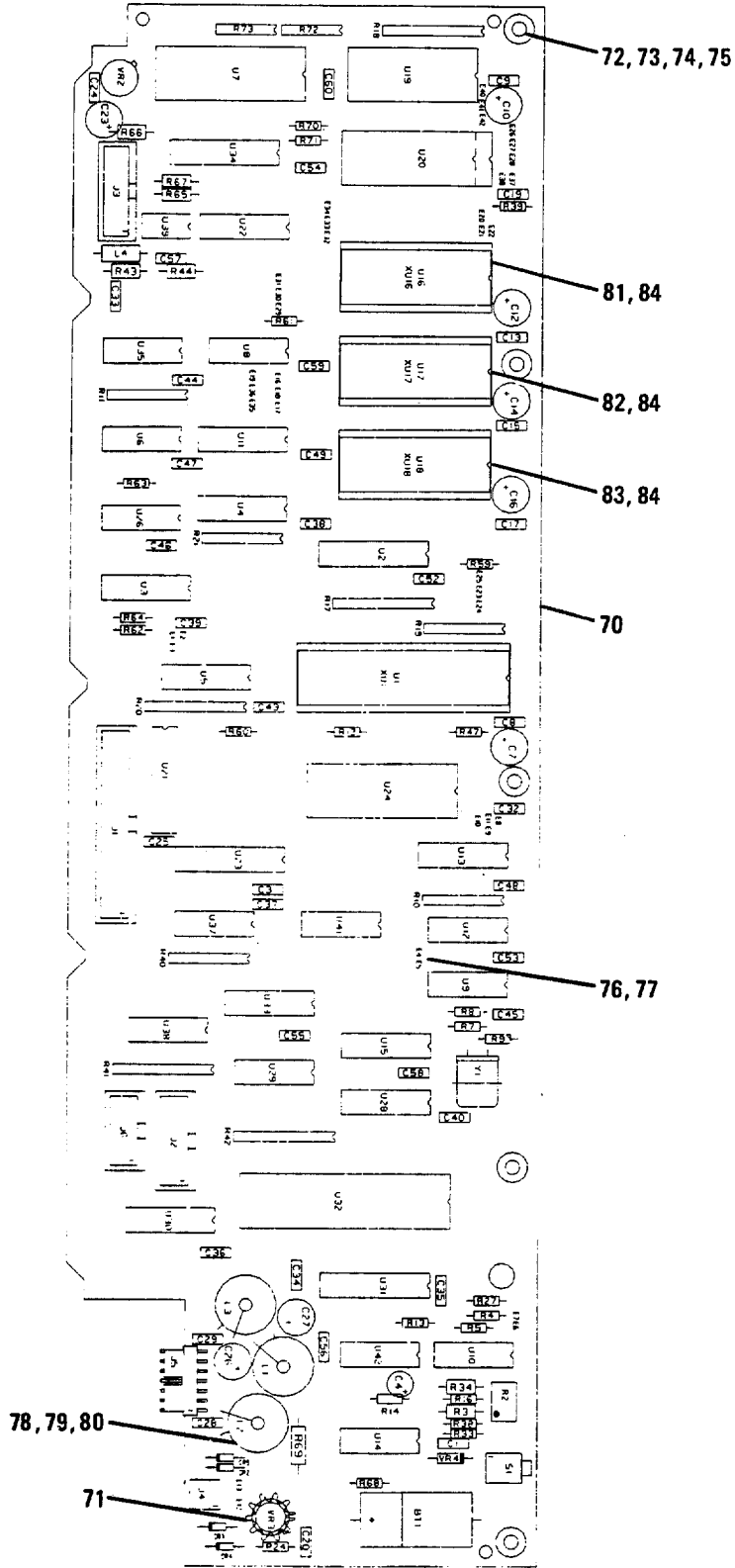

350-124

Figure 7-25. Transceiver Control PWB Assy A1A12



## NOTE

To find index numbers for circuit board components, use the reference designator index at the end of this chapter. The complete reference designator for a circuit board component consists of "1," followed by the assembly designator (A1A1, A1A2, etc.), then the reference designator on the illustration. For example, the complete reference designator for R25 on the Exciter PWB Assy is 1A1A1 R25.

Figure & Index Number	Part Number	FSCM	Description							Units Per Assy	Usable On Code	SMR Code
			1	2	3	4	5	6	7			
7-25-	10085-9000	14304	CIRCUIT CARD ASSY,A1A12							1		PAODD
- 1	TO4/43	55002	. BATTERY, LITHIUM							1		XB
- 2	CK06BX104K	81349	. CAPACITOR, FXD, CER							38		PADZZ
- 3	T392B155M035AS	31433	. CAP, FXD, ELCTLT							2		PADZZ
- 4	T392F157K010AS	31433	. CAP, FXD, ELCTLT							5		PADZZ
- 5	T392E476K025AS	31433	. CAP, FXD, ELCTLT							2		PADZZ
- 6	T392F157M010AS	31433	. CAP, FXD, ELCTLT							5		PADZZ
- 7	T392E476M025AS	31433	. CAP, FXD, ELCTLT							2		PADZZ
- 8	JAN1N4454	81349	. SEMICONV DEVICE, DIO							4		PADZZ
- 9	609-3427	15912	. CONNECTOR, RCPT, ELEC							1		PADZZ
- 10	609-1427	59730	. CONNECTOR, RCPT, ELEC							2		PADZZ
- 11	22-12-2034	27264	. CONNECTOR, RCPT, ELEC							1		PADZZ
- 12	22-12-2074	27264	. CONNECTOR, RCPT, ELEC							1		PADZZ
- 13	609-1027	15912	. CONNECTOR, RCPT, ELEC							1		PADZZ
- 14	10073-7034	14304	. COIL, RF							3		PADZZ
- 15	MS14046-4	96906	. COIL, RF							1		PADZZ
- 16	RJR24FW502D	81349	. RESISTOR, VARIABLE							1		PADZZ
- 17	RN55D2002F	81349	. RESISTOR FXD FILM							2		PADZZ
- 18	CF07-102J	78488	. RESISTOR, FXD, COMP							8		PADZZ
- 19	CF07-105J	78488	. RESISTOR, FXD, COMP							1		PADZZ
- 20	CF07-182J	78488	. RESISTOR, FXD, COMP							2		PADZZ
- 21	CF07-333J	78488	. RESISTOR, FXD, COMP							1		PADZZ
- 22	4308R-101-103	32997	. RESISTOR, NETWORK							5		PADZZ
- 23	CF07-472J	78488	. RESISTOR, FXD, COMP							2		PADZZ
- 24	CF07-103J	78488	. RESISTOR, FXD, COMP							4		PADZZ
- 25	CF07-473J	78488	. RESISTOR, FXD, COMP							3		PADZZ
- 26	CF07-104J	78488	. RESISTOR, FXD, COMP							2		PADZZ
- 27	4310R-101-103	32997	. RESISTOR, NETWORK							5		PADZZ
- 28	RN55D3322F	81349	. RESISTOR, FXD, COMP							1		PADZZ
- 29	RN55D1002F	81349	. RESISTOR, FXD, FILM							2		PADZZ
- 30	RN55D1003F	81349	. RESISTOR, FXD, FILM							1		PADZZ
- 31	RN55D1001F	81349	. RESISTOR, FXD, FILM							1		PADZZ
- 32	CF07-220J	78488	. RESISTOR, FXD, XOMP							1		PADZZ
- 33	ERD50TJ100	54473	. RESISTOR, FXD, COMP							1		PADZZ
- 34	4306R-102-472	57922	. RESISTOR FXD SIP							2		PADZZ
- 35	TPA11FG-RA6	95146	. SWITCH							1		PADZZ
- 36	TD8088	34649	. MICROCIRCUIT							1		PADZZ
- 37	M38510/32502BRW	81349	. MICROCIRCUIT							1		PADZZ
- 38	10085-9550	14304	. MICROCIRCUIT							1		PADZZ
- 39	M38510/30702BEB	81349	. MICROCIRCUIT							2		PADZZ
- 40	SN54LS138J	01295	. MICROCIRCUIT							1		PADZZ
- 41	M38510/31004BCB	81349	. MICROCIRCUIT							2		PADZZ
- 42	ADC0808CCJ	27014	. MICROCIRCUIT							1		PADZZ
- 43	M38510/30003BCB	81349	. MICROCIRCUIT							4		PADZZ
- 44	SN54LS04J	01295	. MICROCIRCUIT							4		PADZZ

Figure & Index Number	Part Number	FSCM	Description							Units Per Assy	Usable On Code	SMR Code													
			1	2	3	4	5	6	7																
- 45	M38510/11201BCB	81349	.	M	I	C	R	O	C	I	R	C	U	I	T	1	PADZZ								
- 46	SN54LS161AJ	01295	.	M	I	C	R	O	C	I	R	C	U	I	T	1	PADZZ								
- 47	SN54LS92J	01295	.	M	I	C	R	O	C	I	R	C	U	I	T	1	PADZZ								
- 48	CD4020BF	02735	.	M	I	C	R	O	C	I	R	C	U	I	T	1	PADZZ								
- 49	CD4016BF	02735	.	M	I	C	R	O	C	I	R	C	U	I	T	1	PADZZ								
- 50	SN54LS165J	01295	.	M	I	C	R	O	C	I	R	C	U	I	T	2	PADZZ								
- 51	TC5516APL	61802	.	M	I	C	R	O	C	I	R	C	U	I	T	2	PADZZ								
- 52	SN54LS245J	01295	.	M	I	C	R	O	C	I	R	C	U	I	T	2	PADZZ								
- 53	12303713	19207	.	M	I	C	R	O	C	I	R	C	U	I	T	1	PADZZ								
- 54	SN54LS244J	01295	.	M	I	C	R	O	C	I	R	C	U	I	T	1	PADZZ								
- 55	TD8259A	34649	.	M	I	C	R	O	C	I	R	C	U	I	T	1	PADZZ								
- 56	SN54LS74AJ	01295	.	M	I	C	R	O	C	I	R	C	U	I	T	2	PADZZ								
- 57	SN54LS367AJ	01295	.	M	I	C	R	O	C	I	R	C	U	I	T	1	PADZZ								
- 58	SN54LS299J	01295	.	M	I	C	R	O	C	I	R	C	U	I	T	1	PADZZ								
- 59	TD8255A	34649	.	M	I	C	R	O	C	I	R	C	U	I	T	1	PADZZ								
- 60	SN54LS139J	01295	.	M	I	C	R	O	C	I	R	C	U	I	T	2	PADZZ								
- 61	SN54LS00J	01295	.	M	I	C	R	O	C	I	R	C	U	I	T	2	PADZZ								
- 62	SN54LS08J	01295	.	M	I	C	R	O	C	I	R	C	U	I	T	2	PADZZ								
- 63	MC1558U	04713	.	M	I	C	R	O	C	I	R	C	U	I	T	1	PADZZ								
- 64	403897-1	12909	.	M	I	C	R	O	C	I	R	C	U	I	T	2	PADZZ								
- 65	JAN1N759A	81349	.	S	E	M	I	C	O	N	D		D	I	O	1	PADZZ								
- 66	UA78M05HM	07263	.	M	I	C	R	O	C	I	R	C	U	I	T	1	PADZZ								
- 67	540-AG11D	91506	.	C	O	N	N	E	C	T	O	R		R	C	P		E	L	E	C	1	PADZZ		
- 68	528-AG11D	91506	.	C	O	N	N	E	C	T	O	R		R	C	P		E	L	E	C	3	PADZZ		
- 69	MP150	71450	.	C	R	I	S	T	A	L											1	PADZZ			
- 70	10085-9009	14304	.	C	I	R	C	U	I	T		C	A	R	D							1	XA		
- 71	2260R	13103	.	H	E	A	T	S	I	N	K		E	L	E	C	T					1	PADZZ		
- 72	MS35338-135	96906	.	W	A	S	H	E	R			S	P	L	I	T						5	PADZZ		
- 73	MS51957-17	96906	.	S	C	R	E	W				M	A	C	H	I	N	E					5	PADZZ	
- 74	6611-0135	14304	.	R	E	T	A	I	N	E	R											5	PADZZ		
- 75	10085-5156	14304	.	B	U	S	H	I	N	G												5	PADZZ		
- 76	65474-001	00779	.	J	U	M	P	E	R													2	PADZZ		
- 77	65499-102	00779	.	J	A	C	K															2	PADZZ		
- 78	010440B062	13764	.	S	C	R	E	W				M	A	C	H	I	N	E					3	PADZZ	
- 79	103101	73734	.	N	U	T						N	O	N	M	E	T	A	L	I	C		3	PADZZ	
- 80	2717-24850-N126	26344	.	W	A	S	H	E	R														6	PADZZ	
- 81	10085-9570	14304	.	E	P	R	O	M															1	PADZZ	
- 82	10085-9510	14304	.	E	P	R	O	M																1	PADZZ
- 83	10085-9520	14304	.	E	P	R	O	M																1	PADZZ
- 84	TD271-28-4	34649	.	E	P	R	O	M																3	PADZZ



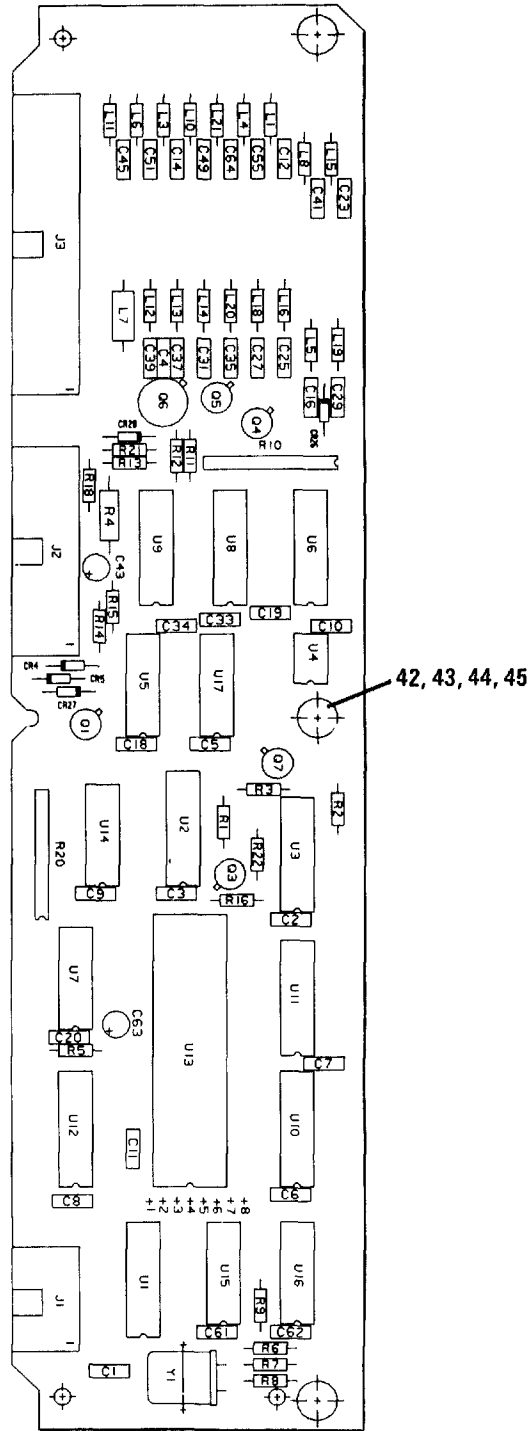

350-125

Figure 7-26. LPA/Coupler Interface PWB Assy, A1A13

## NOTE

To find index numbers for circuit board components, use the reference designator index at the end of this chapter. The complete reference designator for a circuit board component consists of "1," followed by the assembly designator (A1A1, A1A2, etc.), then the reference designator on the illustration. For example, the complete reference designator for R25 on the Exciter PWB Assy is 1A1A1 R25.

Figure & Index Number	Part Number	FSCM	Description							Units Per Assy	Usable On Code	SMR Code
			1	2	3	4	5	6	7			
7-26-	10085-7000	14304	CIRCUIT CARD ASSY,A1A13							1		PA0DD
- 1	CK06BX104K	81349	. CAPACITOR, FXD, CER							17		PADZZ
- 2	CK06BX103K	81349	. CAPACITOR, FXD, CER							12		PADZZ
- 3	CK06BX474K	81349	. CAPACITOR, FXD, CER							6		PADZZ
- 4	T392B106M010AS	31433	. CAP, FXD, ELCTLT							2		PADZZ
- 5	JAN1N4454	81349	. SEMICONV DEVICE, DIO							5		PADZZ
- 6	609-1007	59730	. CONNECTOR, RCPT, ELEC							1		PADZZ
- 7	609-2607	15912	. CONNECTOR, RCPT, ELEC							1		PADZZ
- 8	3495-1002	26066	. CONNECTOR, RCPT, ELEC							1		PADZZ
- 9	MS75085-2	96906	. COIL, RF							11		PADZZ
- 10	MS75085-19	96906	. COIL, RF							6		PADZZ
- 11	MS14046-6	96906	. COIL, RF							1		PADZZ
- 12	JAN2N2222A	81349	. TRANSISTOR							5		PADZZ
- 13	2N4236	80131	. TRANSISTOR							1		PADZZ
- 14	CF07-102J	78488	. RESISTOR, FXD, COMP							1		PADZZ
- 15	CF07-121J	78488	. RESISTOR, FXD, COMP							1		PADZZ
- 16	CF07-562J	78488	. RESISTOR, FXD, COMP							4		PADZZ
- 17	ERD50TJ561	54473	. RESISTOR, FXD, COMP							1		PADZZ
- 18	CF07-151J	78488	. RESISTOR, FXD, COMP							1		PADZZ
- 19	CF07-182J	78488	. RESISTOR, FXD, COMP							3		PADZZ
- 20	CF07-103J	78488	. RESISTOR, FXD, COMP							2		PADZZ
- 21	CF07-472J	78488	. RESISTOR, FXD, COMP							1		PADZZ
- 22	4310R-101-471	32997	. RESISTOR NETWORK							1		PADZZ
- 23	CF07-222J	78488	. RESISTOR, FXD, COMP							1		PADZZ
- 24	CF07-512J	78488	. RESISTOR, FXD, COMP							1		PADZZ
- 25	CF07-220J	78488	. RESISTOR, FXD, XOMP							1		PADZZ
- 26	4310R-101-103	32997	. RESISTOR, NETWORK							1		PADZZ
- 27	CF07-3R9J	78488	. RESISTOR, FXD, COMP							1		PADZZ
- 28	SN54LS138J	01295	. MICROCIRCUIT							1		PADZZ
- 29	SN54LS368AJ	01295	. MICROCIRCUIT							1		PADZZ
- 30	SN54LS367AJ	01295	. MICROCIRCUIT							2		PADZZ
- 31	H11L2	03508	. MICROCIRCUIT							1		PADZZ
- 32	SN5416J	01295	. MICROCIRCUIT							1		PADZZ
- 33	CD4021BF	02735	. MICROCIRCUIT							3		PADZZ
- 34	M38510/30005BCB	81349	. MICROCIRCUIT							1		PADZZ
- 35	CD4094BF	02735	. MICROCIRCUIT							2		PADZZ
- 36	IM64021DL	32293	. MICROCIRCUIT							1		PADZZ
- 37	SN54LS74AJ	01295	. MICROCIRCUIT							1		PADZZ
- 38	SN54LS393J	04713	. MICROCIRCUIT							1		PADZZ
- 39	SN54LS04J	01295	. MICROCIRCUIT							1		PADZZ
- 40	CD4001BF	02735	. MICROCIRCUIT							1		PADZZ
- 41	10085-7009	14304	. CIRCUIT CARD							1		XA
- 42	661i-0135	14304	. RETAINER, SCREW							3		PADZZ
- 43	10085-5156	14304	. BUSHING							3		PADZZ
- 44	MS51957-17	96906	. SCREW, MACHINE (AP)							3		PADZZ
- 45	MS35338-135	96906	. WASHER, SPLIT (AP)							3		PADZZ

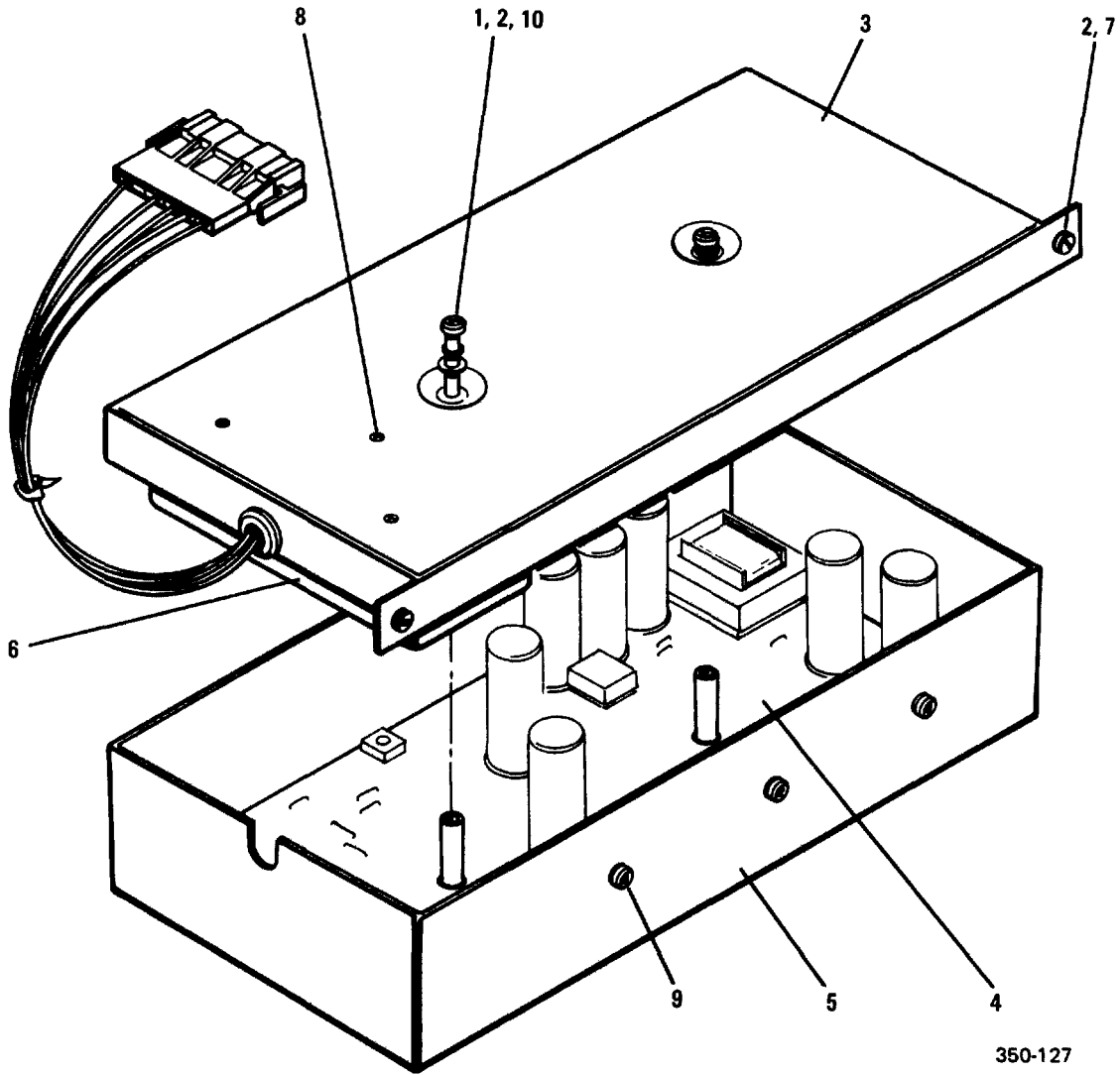

Figure 7-27. Multivoltage Supply Assy, A1A14

## NOTE

To find index numbers for circuit board components, use the reference designator index at the end of this chapter. The complete reference designator for a circuit board component consists of "1," followed by the assembly designator (A1A1, A1A2, etc.), then the reference designator on the illustration. For example, the complete reference designator for R25 on the Exciter PWB Assy is 1A1A1 R25.

Figure & Index Number	Part Number	FSCM	Description 1 2 3 4 5 6 7	Units	Usable	SMR Code
				Per Assy	On Code	
7-27-	10085-1240	14304	MULTIVOLT SPLY ASSY,A1A14	1		PAODD
- 1	MS15795-805	96906	. WASHER,FLAT (AP)	2		PADZZ
- 2	MS35338-136	96906	. WASHER,SPLIT (AP)	4		PADZZ
- 3	10085-1209	14304	. COVER	1		XB
- 4	10085-1260	14304	. CIRCUIT CARD ASSY	1		XA
- 5	10085-1247	14304	. CASE	1		XB
- 6	10085-1230	14304	. FILTER ASSY,RF	1		PADZZ
- 7	6232-SS-0632	06540	. SCREW EXT RELIEVED	2		PAOZZ
- 8	MS24693-C16	96906	. SCREW,MACHINE (AP)	3		PAOZZ
- 9	MS51957-28	96906	. SCREW,MACHINE (AP)	3		PADZZ
- 10	10085-5131	14304	. SCREW,MACHINE (AP)	2		PADZZ

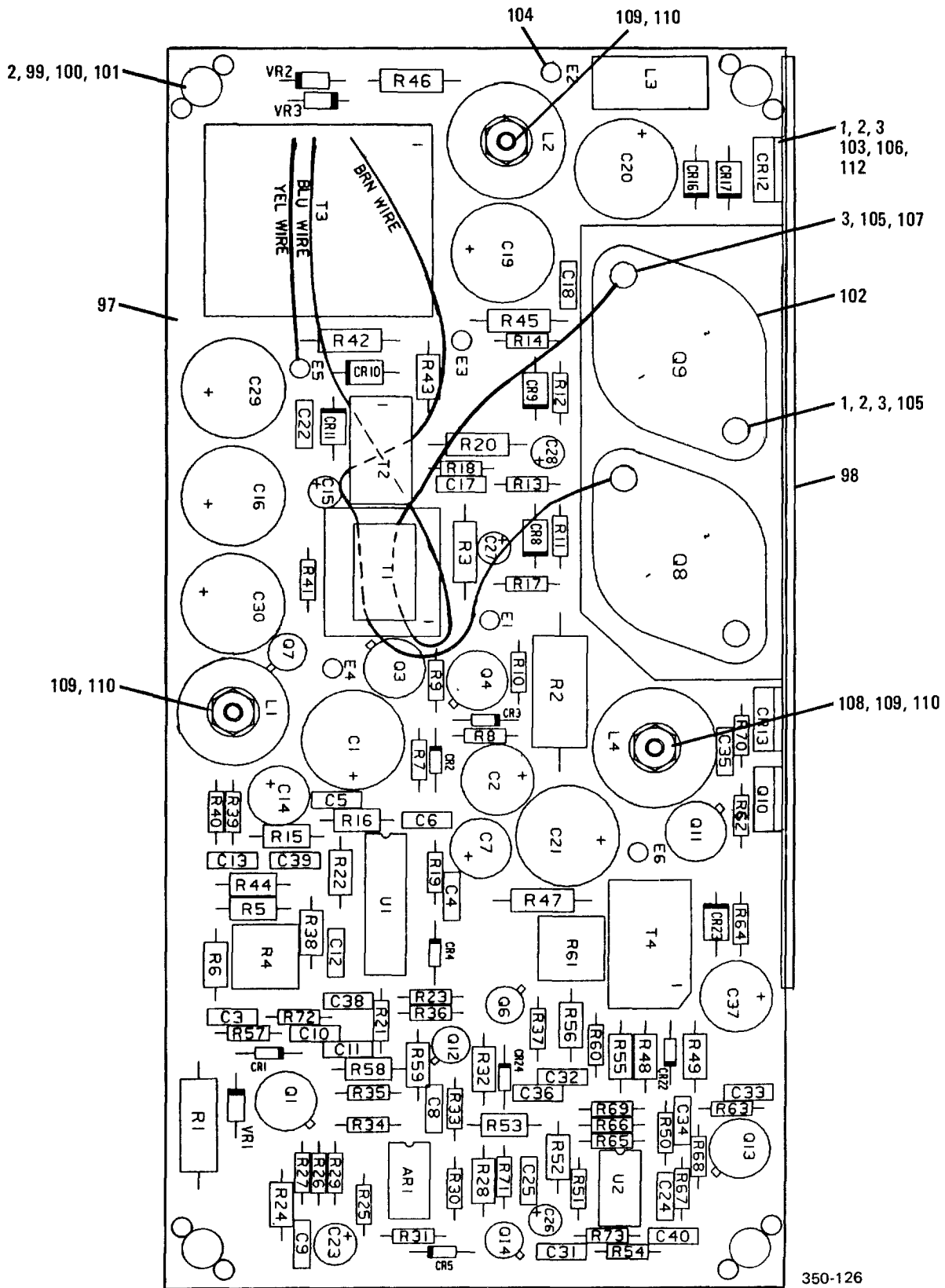

Figure 7-28. Multivoltage Supply PWB Assy, A1A14A1



## NOTE

To find index numbers for circuit board components, use the reference designator index at the end of this chapter. The complete reference designator for a circuit board component consists of "1," followed by the assembly designator (A1A1, A1A2, etc.), then the reference designator on the illustration. For example, the complete reference designator for R25 on the Exciter PWB Assy is 1A1A1 R25.

Figure & Index Number	Part Number	FSCM	Description							Units Per Assy	Usable On Code	SMR Code
			1	2	3	4	5	6	7			
7-28-	10085-1260	14304	CIRCUIT CARD ASSY, A1A14A1							1		XA
- 1	MS15795-803	96906	. WASHER, FLAT (AP)							5		PADZZ
- 2	MS35338-135	96906	. WASHER, SPLIT (AP)							9		PADZZ
- 3	MS35649-244	96906	. NUT, PLAIN, HEX							7		PADZZ
- 4	MC1558U	04713	. MICROCIRCUIT							1		PADZZ
- 5	672D337H040ET5	56289	. CAP, FXD, ELCTLT							6		PADZZ
- 6	801591-31	96214	. CAP, FXD, ELCTLT							1		PADZZ
- 7	M39014/02-1344	81349	. CAPACITOR, FXD, CER							1		PADZZ
- 8	CKO6BX104K	81349	. CAPACITOR, FXD, CER							6		PADZZ
- 9	0180-2827	28480	. CAP, FXD, ELCTLT							2		PADZZ
- 10	CKO6BX103K	81349	. CAPACITOR, FXD, CER							4		PADZZ
- 11	CK05BX102K	81349	. CAPACITOR, FXD, CER							3		PADZZ
- 12	M39014/02-1340	81349	. CAPACITOR, FXD, CER							1		PADZZ
- 13	CKO6BX474K	81349	. CAPACITOR, FXD, CER							4		PADZZ
- 14	T392D226M025AS	31433	. CAP, FXD, ELCTLT							1		PADZZ
- 15	T392B335M025AS	31433	. CAP, FXD, ELCTLT							2		PADZZ
- 16	672D337H040ET50	56289	. CAP, FXD, ELCTLT							6		PADZZ
- 17	672D108H015ET5C	56289	. CAP, FXD, ELCTLT							1		PADZZ
- 18	M39014/02-1332	81349	. CAPACITOR, FXD, CER							1		PADZZ
- 19	T392C106M025AS	31433	. CAP, FXD, ELCTLT							1		PADZZ
- 20	T392B155M035AS	31433	. CAP, FXD, ELCTLT							2		PADZZ
- 21	CKO6BX223K	81349	. CAPACITOR, FXD, CER							1		PADZZ
- 22	672D476H040CD5C	56289	. CAP, FXD, ELCTLT							2		PADZZ
- 23	CKO6BX332K	81349	. CAPACITOR, FXD, CER							1		PADZZ
- 24	CKO6BX273K	81349	. CAPACITOR, FXD, CER							1		PADZZ
- 25	M39014/02-1335	81349	. CAPACITOR, FXD, CER							1		PADZZ
- 26	JAN1N3611	81349	. SEMICOND DEVICE, DIO							1		PADZZ
- 27	JAN1N4454	81349	. SEMICOND DEVICE, DIO							6		PADZZ
- 28	JAN1N5417	81349	. SEMICOND DEVICE, DIO							7		PADZZ
- 29	RUR-D820	18722	. SEMICOND DEVICE, DIO							1		PADZZ
- 30	VHE1402	27777	. SEMICOND DEVICE, DIO							1		PADZZ
- 31	L13-0002-470	14304	. COIL, RF							1		PADZZ
- 32	L13-0002-331	14304	. COIL, RF							1		PADZZ
- 33	10085-1228	14304	. COIL, RF							1		PADZZ
- 34	10085-1268	14304	. COIL, RF							1		PADZZ
- 35	JAN2N3439	81349	. TRANSISTOR							2		PADZZ
- 36	JAN2N2219A	81349	. TRANSISTOR							2		PADZZ
- 37	JAN2N2222A	81349	. TRANSISTOR							2		PADZZ
- 38	JAN2N6341	81349	. TRANSISTOR							2		PADZZ
- 39	JAN2N6338	81349	. TRANSISTOR							2		PADZZ
- 40	151-0625-00	80009	. TRANSISTOR							1		PADZZ
- 41	2N4236	80131	. TRANSISTOR							1		PADZZ
- 42	JAN2N2907A	81349	. TRANSISTOR							2		PADZZ
- 43	RCR32G102JS	81349	. RESISTOR, FXD, COMP							1		PADZZ
- 44	RCR42G221JS	81349	. RESISTOR, FXD, COMP							1		PADZZ

Figure & Index Number	Part Number	FSCM	Description							Unlts Per Assy	Usable On Code	SMR Code
			1	2	3	4	5	6	7			
- 45	ERD50TJ100	54473	.	RESISTOR	FXD	COMP				2		PADZZ
- 46	72PM2K	73138	.	RESISTOR	VARIABLE					1		PADZZ
- 47	RNC55K1152FS	81349	.	RESISTOR	FXD	FILM				1		PADZZ
- 48	RN55K2491FS	81349	.	RESISTOR	FXD	FILM				1		PADZZ
- 49	CF07-182J	78488	.	RESISTOR	FXD	COMP				2		PADZZ
- 50	CF07-471J	78488	.	RESISTOR	FXD	COMP				4		PADZZ
- 51	CF07-220J	78488	.	RESISTOR	FXD	XOMP				4		PADZZ
- 52	CF07-6R8J	78488	.	RESISTOR	FXD	COMP				2		PADZZ
- 53	RN55D4991F	81349	.	RESISTOR	FXD	FILM				2		PADZZ
- 54	CF07-2R7J	78488	.	RESISTOR	FXD	COMP				2		PADZZ
- 55	CF07-104J	78488	.	RESISTOR	FXD	COMP				2		PADZZ
- 56	CF07-333J	78488	.	RESISTOR	FXD	COMP				1		PADZZ
- 57	RN55D2211F	81349	.	RESISTOR	FXD	FILM				4		PADZZ
- 58	CF07-272J	78488	.	RESISTOR	FXD	COMP				2		PADZZ
- 59	RNC55K1102FS	81349	.	RESISTOR	FXD	FILM				1		PADZZ
- 60	CF07-103J	78488	.	RESISTOR	FXD	COMP				4		PADZZ
- 61	RN55D6811F	81349	.	RESISTOR	FXD	FILM				3		PADZZ
- 62	RN55D1003F	81349	.	RESISTOR	FXD	FILM				1		PADZZ
- 63	RNC55K8061FS	81349	.	RESISTOR	FXD	FILM				1		PADZZ
- 64	RNC55K2003FS	81349	.	RESISTOR	FXD	FILM				1		PADZZ
- 65	RN55D3321F	81349	.	RESISTOR	FXD	FILM				1		PADZZ
- 66	CF07-681J	78488	.	RESISTOR	FXD	COMP				1		PADZZ
- 67	CF07-102J	78488	.	RESISTOR	FXD	COMP				2		PADZZ
- 68	CF07-100J	78488	.	RESISTOR	FXD	COMP				3		PADZZ
- 69	RN55D1000F	81349	.	RESISTOR	FXD	FILM				1		PADZZ
- 70	CF07-101J	78488	.	RESISTOR	FXD	COMP				4		PADZZ
- 71	RNC60K23R7FS	81349	.	RESISTOR	FXD	FILM				1		PADZZ
- 72	RNC55K2150FS	81349	.	RESISTOR	FXD	FILM				1		PADZZ
- 73	RN55D4750F	81349	.	RESISTOR	FXD	COMP				1		PADZZ
- 74	ERD50TJ102	54473	.	RESISTOR	FXD	COMP				1		PADZZ
- 75	RLR20C22R1FS	81349	.	RESISTOR	FXD	COMP				1		PADZZ
- 76	ERD50TJ271	54473	.	RESISTOR	FXD	COMP				1		PADZZ
- 77	RNC55K4640FS	81349	.	RESISTOR	FXD	FILM				1		PADZZ
- 78	RN55D8R25F	81349	.	RESISTOR	FXD	FILM				1		PADZZ
- 79	CF07-224J	78488	.	RESISTOR	FXD	COMP				1		PADZZ
- 80	RN55D4990F	81349	.	RESISTOR	FXD	FILM				1		PADZZ
- 81	CF07-222J	78488	.	RESISTOR	FXD	COMP				1		PADZZ
- 82	3386B-1-501	32997	.	RESISTOR	VARIABLE					1		PADZZ
- 83	CF07-221J	78488	.	RESISTOR	FXD	COMP				1		PADZZ
- 84	CF07-682J	78488	.	RESISTOR	FXD	COMP				1		PADZZ
- 85	CF07-472J	78488	.	RESISTOR	FXD	COMP				2		PADZZ
- 86	CF07-332J	78488	.	RESISTOR	FXD	COMP				1		PADZZ
- 87	CF07-473J	78488	.	RESISTOR	FXD	COMP				1		PADZZ
- 88	10085-1224	14304	.	TRANSFORMER	RF					1		PADZZ
- 89	51718	61735	.	TRANSFORMER	RF					1		PADZZ
- 90	10085-1225	14304	.	TRANSFORMER	RF					1		PADZZ
- 91	10085-1266	14304	.	TRANSFORMER	RF					1		PADZZ
- 92	SG1524F	18324	.	MICROCIRCUIT						1		PADZZ
- 93	SE5561FE	18324	.	MICROCIRCUIT						1		PADZZ
- 94	1N4743A	81349	.	SEMICOND DEVICE	DIO					1		PADZZ
- 95	JAN1N4463	81349	.	SEMICOND DEVICE	DIO					2		PADZZ

Figure & Index Number	Part Number	FSCM	Description 1 2 3 4 5 6 7	Units	Usable	SMR Code
				Per Assy	On Code	
- 96	1N4738A	80131	. SEMICOND DEVICE, DIO	2		PADZZ
- 97	10085-1269	14304	. CIRCUIT CARD	1		XA
- 98	10085-1245	14304	. HEATSINK	1		XB
- 99	6611-0135	14304	. RETAINER, SCREW	4		PADZZ
-100	10085-5156	14304	. BUSHING	4		PADZZ
-101	MS51957-17	96906	. SCREW, MACHINE (AP)	4		PADZZ
-102	43-03-4	13103	. INSULATOR PLATE	2		PADZZ
-103	SM-66-52-14	08289	. INSULATOR PLATE	3		PADZZ
-104	61134-1	00779	. TERMINAL QUICK DISC	6		PADZZ
-105	KFH-440-8	99256	. STUD, CLINCH	6		XB
-106	7721-7PPS	13103	. INSULATOR BUSHING	3		PADZZ
-107	MS77068-1	96906	. TERMINAL, LUG	2		PADZZ
-108	2261-N116	06540	. WASHER, FLAT, NYLON	1		XB
-109	010440B112	73734	. SCREW, MACHINE, NYLON	3		XB
-110	103101	73734	. NUT NONMETALIC	3		PADZZ
-111	61060-1	00779	. TERMINAL	1		PADZZ
-112	MS24693-C5	96906	. SCREW, MACHINE (AP)	3		PAOZZ

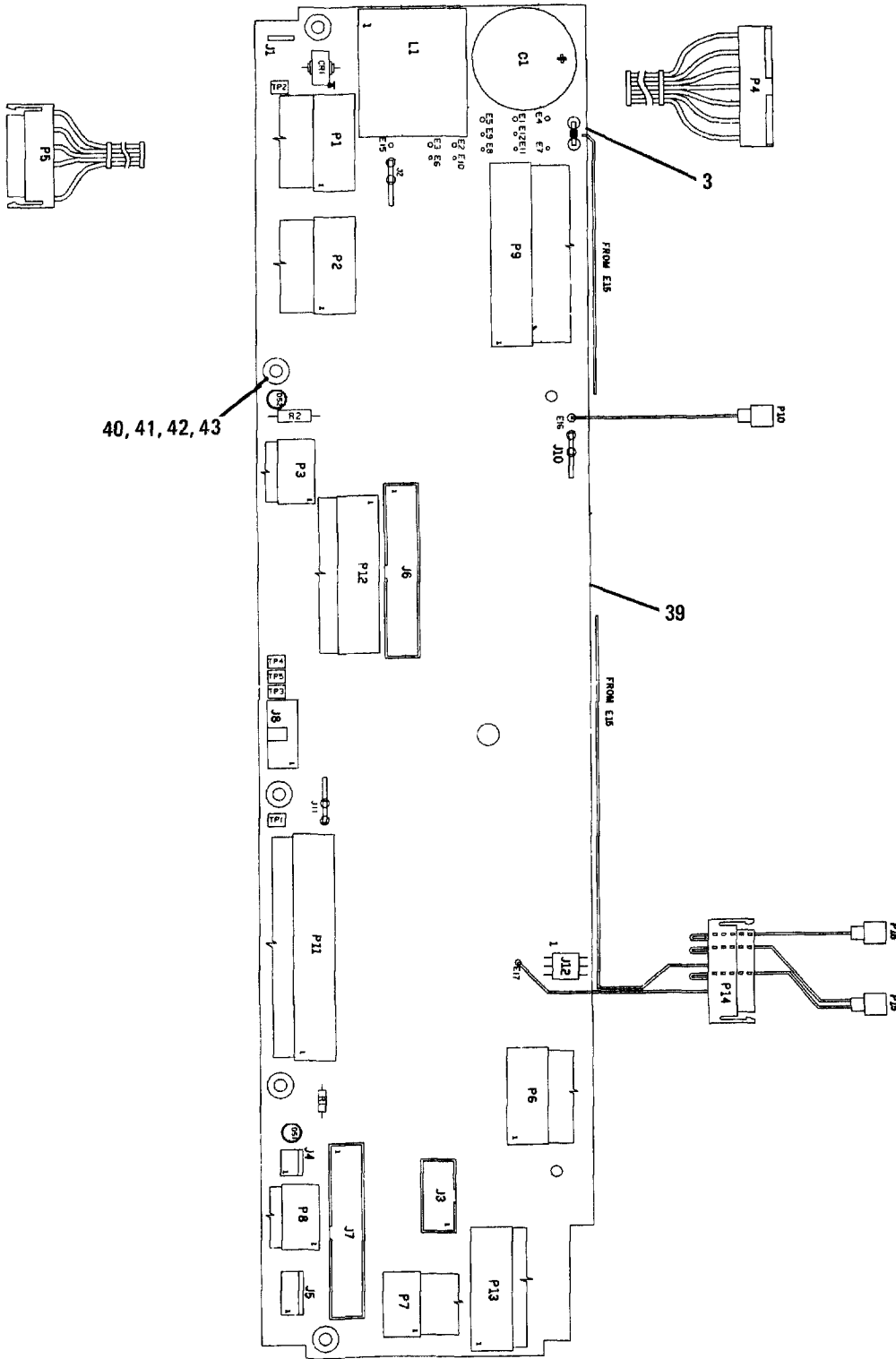

350-128

Figure 7-29. Interconnect PWB Assy, A1A15

## NOTE

To find index numbers for circuit board components, use the reference designator index at the end of this chapter. The complete reference designator for a circuit board component consists of "1," followed by the assembly designator (A1A1, A1A2, etc.), then the reference designator on the illustration. For example, the complete reference designator for R25 on the Exciter PWB Assy is 1A1A1 R25.

Figure & Index Number	Part Number	FSCM	Description							Units Per Assy	Usable On Code	SMR Code
			1	2	3	4	5	6	7			
7-29-	10085-4210	14304	CIRCUIT CARD ASSY,A1A15							1		PAOLD
- 1	80D222P050KA5	56289	. CAP,FXD,ELCTLT							1		PADZZ
- 2	MR826	04713	. SEMICOND DEVICE,DIO							1		PADZZ
- 3	MS3367-4-9	96906	. STRAP,TIE DOWN							1		PADZZ
- 4	HLMP-3301	50434	. LED							2		PADZZ
- 5	62409-1	00779	. TERMINAL							2		PADZZ
- 6	949	79963	. TERMINAL,MALE							3		PADZZ
- 7	609-1027	15912	. CONNECTOR,RCPT,ELEC							1		PADZZ
- 8	22-11-2032	27264	. CONN RECP ELECT							1		PADZZ
- 9	22-11-2052	27264	. CONNECTOR,RCPT,ELEC							1		PADZZ
- 10	609-3427	15912	. CONNECTOR,RCPT,ELEC							2		PADZZ
- 11	609-1007	59730	. CONNECTOR,RCPT,ELEC							1		PADZZ
- 12	22-12-2034	27264	. CONNECTOR,RCPT,ELEC							1		PADZZ
- 13	10073-3051	14304	. COIL,RF							1		PADZZ
- 14	10085-0332	14304	. CABLE ASSY,RF							1		PADZZ
- 15	10085-0333	14304	. CABLE ASSY,RF							1		PADZZ
- 16	10085-0334	14304	. CABLE ASSY,RF							1		PADZZ
- 17	10085-0337	14304	. CABLE ASSY,RF							1		PADZZ
- 18	10085-0338	14304	. CABLE ASSY,RF							1		PADZZ
- 19	10085-0339	14304	. CABLE ASSY,RF							1		PADZZ
- 20	10085-0340	14304	. CABLE ASSY,RF							1		PADZZ
- 21	2-520184-4	00779	. TERMINAL,FEMALE							1		XB
- 22	10085-0341	14304	. CABLE ASSY,RF							1		PADZZ
- 23	10085-0342	14304	. CABLE ASSY,RF							1		PADZZ
- 24	10085-0343	14304	. CABLE ASSY,RF							1		PADZZ
- 25	3-520117-2	00779	. TERMINAL,FEMALE							1		XB
- 26	61059-1	00779	. TERMINAL,LUG							1		PADZZ
- 27	22-01-3077	27264	. CONNECTOR,PLUG,ELEC							1		PADZZ
- 28	207377-1	00779	. CONNECTOR,RCPT,ELEC							2		PADZZ
- 29	08-56-0110	27264	. CONNECTOR,PLUG,ELEC							7		PADZZ
- 30	66101-3	00779	. CONTACT ELECTRICAL							9		PADZZ
- 31	66100-3	00779	. CONTACT ELECTRICAL							1		PADZZ
- 32	66098-8	00779	. PIN,CRIMP							1		XB
- 33	CF07-271J	78488	. RESISTOR,FXD,COMP							1		PADZZ
- 34	ERD50TJ122	54473	. RESISTOR,FXD,COMP							1		PADZZ
- 35	105-1102-001	74970	. JACK,TIP							1		PADZZ
- 36	105-1106-001	74970	. JACK,TIP							1		PADZZ
- 37	105-1107-001	74970	. JACK,TIP							1		PADZZ
- 38	105-1104-001	74970	. JACK,TIP							1		PADZZ
- 39	10085-4219	14304	. CIRCUIT CARD							1		XA
- 40	6611-0135	14304	. RETAINER,SCREW							5		PADZZ
- 41	10085-5156	14304	. BUSHING							5		PADZZ
- 42	MS51957-17	96906	. SCREW,MACHINE (AP)							5		PADZZ
- 43	MS35338-135	96906	. WASHER,SPLIT (AP)							5		PADZZ

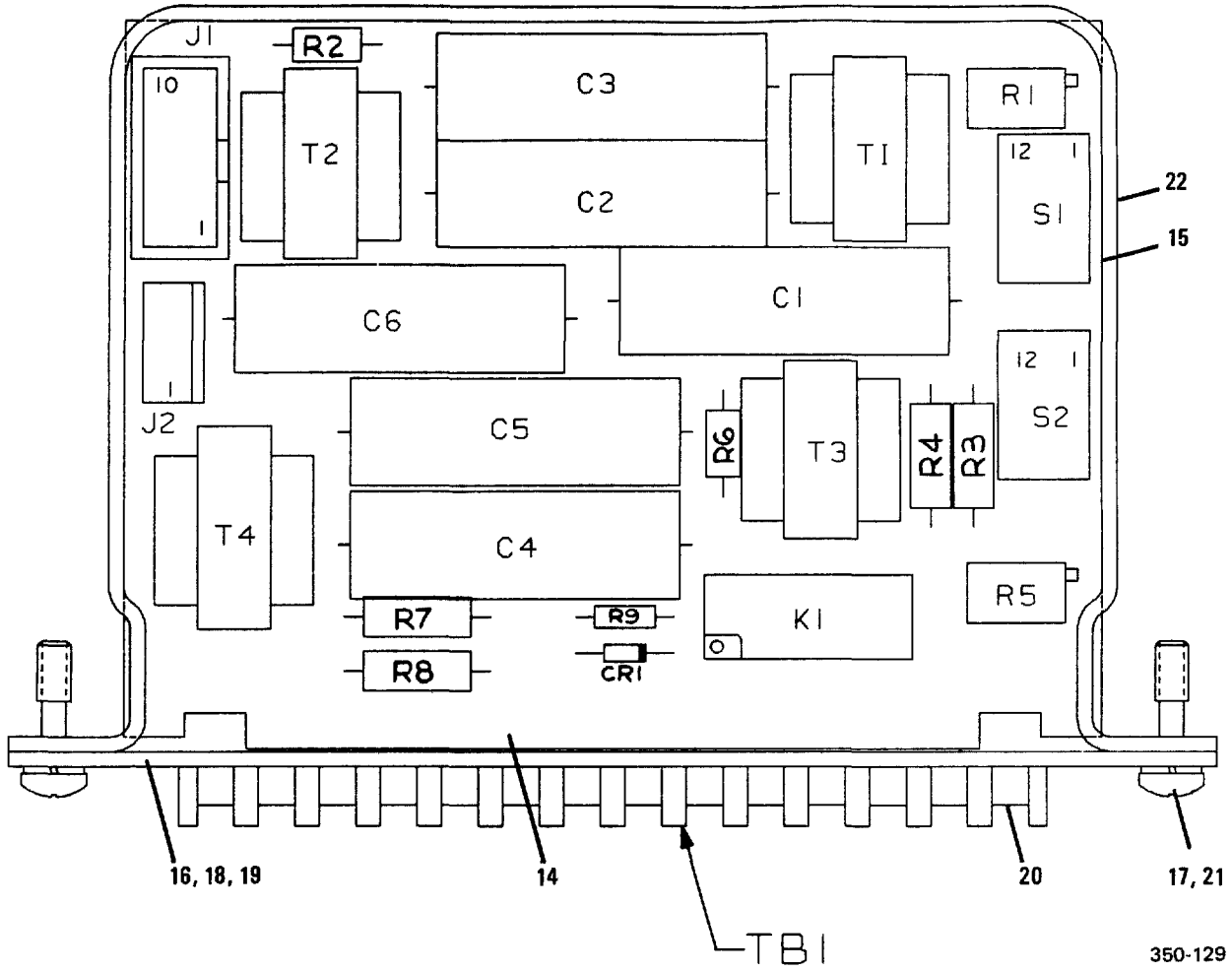

Figure 7-30. Audio Interface PWB Assy, A1A16

## NOTE

To find index numbers for circuit board components, use the reference designator index at the end of this chapter. The complete reference designator for a circuit board component consists of "1," followed by the assembly designator (A1A1, A1A2, etc.), then the reference designator on the illustration. For example, the complete reference designator for R25 on the Exciter PWB Assy is 1A1A1 R25.

Figure & Index Number	Part Number	FSCM	Description							Units Per Assy	Usable On Code	SMR Code
			1	2	3	4	5	6	7			
7-30-	10085-0570	14304	CIRCUIT CARD ASSY,A1A16							1		PA0DD
- 1	JAN1N4454	81349	. SEMICOND DEVICE,DIO							1		PADZZ
- 2	7FR2052B	54904	. CAPACITOR,FXD,MYLAR							6		PADZZ
- 3	609-1027	15912	. CONNECTOR,RCPT,ELEC							1		PADZZ
- 4	22-11-2052	27264	. CONNECTOR,RCPT,ELEC							1		PADZZ
- 5	K-0118	14304	. RELAY							1		PADZZ
- 6	68XR2K	73138	. RESISTOR,VARIABLE							2		PADZZ
- 7	RN55D6040F	81349	. RESISTOR,FXD,FILM							2		PADZZ
- 8	RNC60K3010FS	81349	. RESISTOR,FXD,FILM							4		PADZZ
- 9	RN60D3010F	81349	. RESISTOR,FXD,FILM							4		PADZZ
- 10	CF07-680J	78488	. RESISTOR,FXD,COMP							1		PADZZ
- 11	MSS-4200	95146	. SWITCH							2		PADZZ
- 12	T-2220	26667	. TRANSFORMER,RF							4		PADZZ
- 13	SEPX-12	94464	. TERMINAL,STRIP							1		XB
- 14	10085-0579	14304	. CIRCUIT CARD							1		XA
- 15	10085-0576	14304	. RETAINER							1		XB
- 16	10085-0577	14304	. HOLDER,TERMINAL BLOCK							1		XA
- 17	10085-5131	14304	. SCREW,MACHINE (AP)							2		PADZZ
- 18	MS35338-134	96906	. WASHER,SPLIT (AP)							4		PADZZ
- 19	MS51957-2	96906	. SCREW,MACHINE (AP)							4		PAOZZ
- 20	MS51957-3	96906	. SCREW,MACHINE (AP)							2		PAOZZ
- 21	MS35338-136	96906	. WASHER,SPLIT (AP)							2		PADZZ
- 22	10085-0578	14304	. LABEL							1		MDO

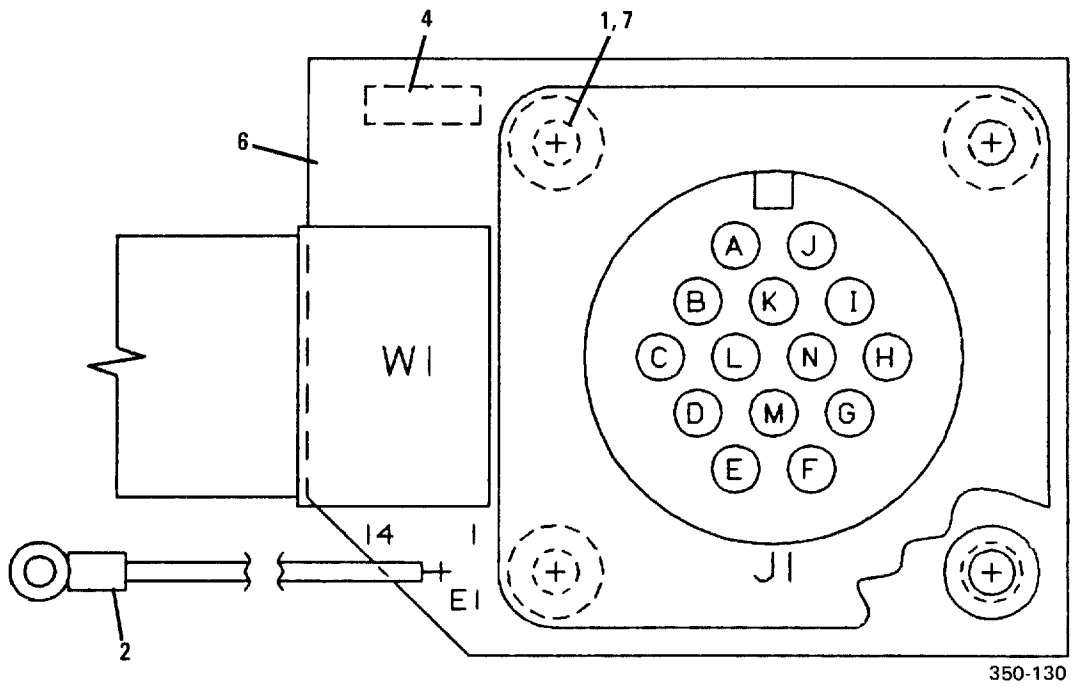

Figure 7-31. Coupler Connector PWB Assy, A1A17



## NOTE

To find index numbers for circuit board components, use the reference designator index at the end of this chapter. The complete reference designator for a circuit board component consists of "1," followed by the assembly designator (A1A1, A1A2, etc.), then the reference designator on the illustration. For example, the complete reference designator for R25 on the Exciter PWB Assy is 1A1A1 R25.

Figure & Index Number	Part Number	FSCM	Description							Units Per Assy	Usable On Code	SMR Code
			1	2	3	4	5	6	7			
7-31-	10085-0550	14304	CIRCUIT CARD ASSY,A1A17							1		PAOLD
- 1	KFB3-440-16ET	06540	. SPACER							4		XB
- 2	61306	79061	. TERMINAL							1		PADZZ
- 3	MS3102R20-27S	96906	. CONNECTOR,RCPT,ELEC							1		PADZZ
- 4	62409-1	00779	. TERMINAL							1		PADZZ
- 5	10085-0347	14304	. CABLE ASSY,RF							1		PADZZ
- 6	10085-0559	14304	. CIRCUIT CARD							1		XA
- 7	KFB3-440-6-HS	99256	. SPACER							4		XB

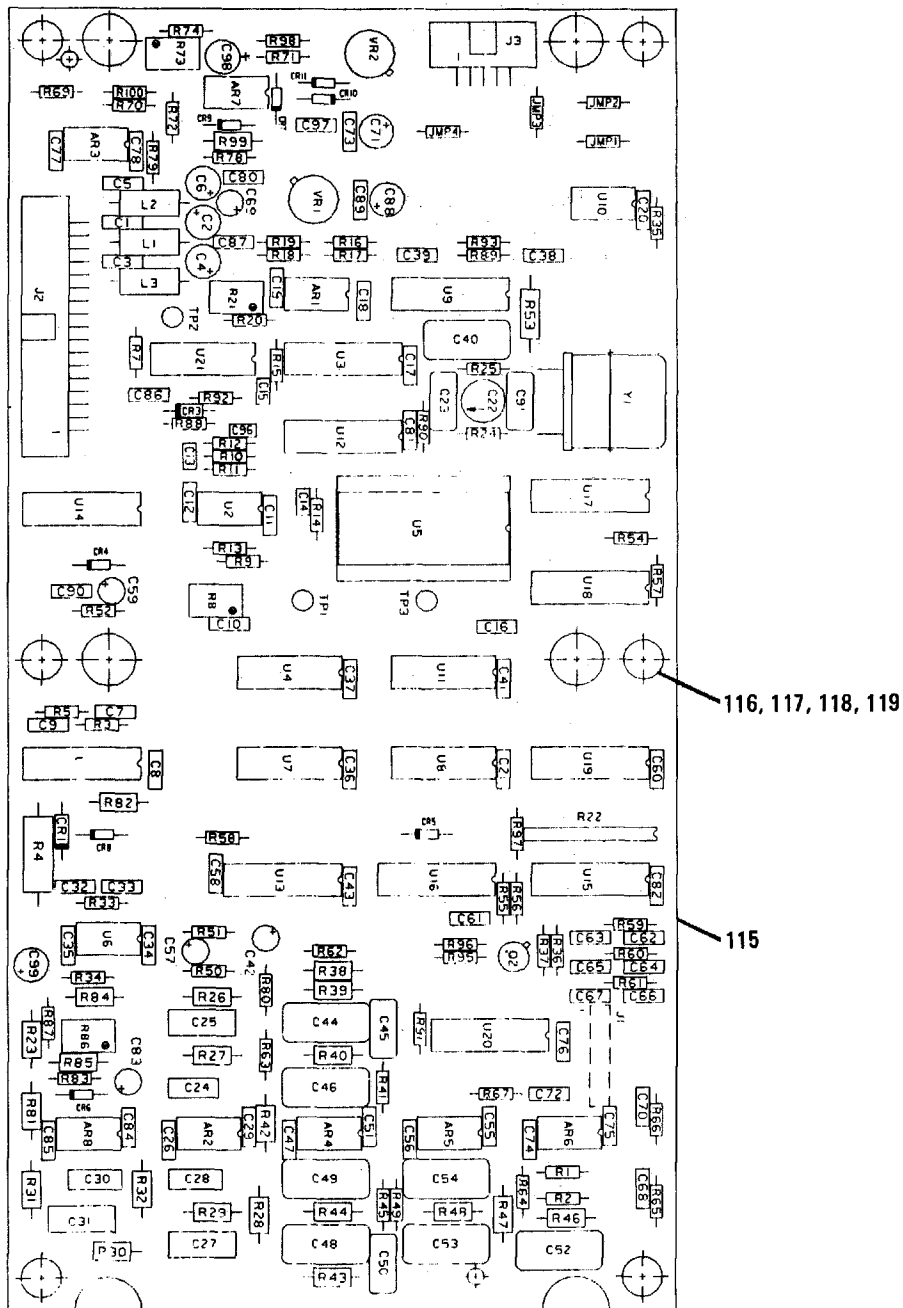

350-131

Figure 7-32. AFSK Keyer/Converter PWB Assy, A1A18A1

## NOTE

To find index numbers for circuit board components, use the reference designator index at the end of this chapter. The complete reference designator for a circuit board component consists of "1," followed by the assembly designator (A1A1, A1A2, etc.), then the reference designator on the illustration. For example, the complete reference designator for R25 on the Exciter PWB Assy is 1A1A1 R25.

Figure & Index Number	Part Number	FSCM	Description							Units Per Assy	Usable On Code	SMR Code
			1	2	3	4	5	6	7			
7-32-	10085-6100	14304	KY/CONV, AFSK ASSY, A1A18A1							1		XA
- 1	LM218J-8	27014	. MICROCIRCUIT							1		PADZZ
- 2	MC1558U	04713	. MICROCIRCUIT							7		PADZZ
- 3	M39014/02-1350	81349	. CAPACITOR, FXD, CER							44		PADZZ
- 4	T392C106M025AS	31433	. CAP, FXD, ELCTLT							6		PADZZ
- 5	CK06BX104K	81349	. CAPACITOR, FXD, CER							44		PADZZ
- 6	M39014/02-1338	81349	. CAPACITOR, FXD, CER							5		PADZZ
- 7	M39014/01-1357	81349	. CAPACITOR, FXD, CER							4		PADZZ
- 8	CK05BX102K	81349	. CAPACITOR, FXD, CER							5		PADZZ
- 9	CV31E600	81349	. CAPACITOR, VARIABLE							1		PADZZ
- 10	CMR05C150J0DR	81349	. CAPACITOR, FXD, MICA							1		PADZZ
- 11	C330C223J1G5CA	31433	. CAPACITOR, FXD, CER							1		PADZZ
- 12	C350C104J1G5CA	31433	. CAPACITOR, FXD, CER							3		PADZZ
- 13	C340C473J1G5CA	31433	. CAPACITOR, FXD, CER							2		PADZZ
- 14	CK06BX103K	81349	. CAPACITOR, FXD, CER							5		PADZZ
- 15	CMR06F392G0DR	81349	. CAPACITOR, FXD, MICA							3		PADZZ
- 16	T392B335M025AS	31433	. CAP, FXD, ELCTLT							4		PADZZ
- 17	CMR06F182G0DR	81349	. CAPACITOR, FXD, MICA							1		PADZZ
- 18	CMR05F161G0DR	81349	. CAPACITOR, FXD, MICA							1		PADZZ
- 19	CMR06F222G0DR	81349	. CAPACITOR, FXD, MICA							1		PADZZ
- 20	CM06FD392J03	81349	. CAPACITOR, FXD, MICA							3		PADZZ
- 21	CMR05F331G0DR	81349	. CAPACITOR, FXD, MICA							1		PADZZ
- 22	CMR06F362G0DR	81349	. CAPACITOR, FXD, MICA							1		PADZZ
- 23	CMR06F432G0DR	81349	. CAPACITOR, FXD, MICA							1		PADZZ
- 24	CMR06F431G0DR	81349	. CAPACITOR, FXD, MICA							1		PADZZ
- 25	M39014/02-1360	81349	. CAPACITOR, FXD, CER							9		PADZZ
- 26	CK06BX474K	81349	. CAPACITOR, FXD, CER							9		PADZZ
- 27	T392B155M035AS	31433	. CAP, FXD, ELCTLC							1		PADZZ
- 28	M39014/02-1358	81349	. CAPACITOR, FXD, CER							1		PADZZ
- 29	CMR05E430G0DR	81349	. CAPACITOR, FXD, MICA							1		PADZZ
- 30	T392D226M025AS	31433	. CAP, FXD, ELCTLT							1		PADZZ
- 31	JAN1N751A	81349	. SEMICOND DEVICE, DIO							1		PADZZ
- 32	JAN1N750A	81349	. SEMICOND DEVICE, DIO							1		PADZZ
- 33	JAN1N4454	81349	. SEMICOND DEVICE							8		PADZZ
- 34	MP-1142	14304	. JUMPER ELECTRICAL							4		XB
- 35	372-2333-020	13499	. CONNECTOR, RCPT, ELEC							1		PADZZ
- 36	609-3407	15912	. CONNECTOR, PLUG, ELEC							1		PADZZ
- 37	609-1007	59730	. CONNECTOR, PLUG, ELEC							1		PADZZ
- 38	MS14046-8	96906	. TRANSFORMER, RF							2		PADZZ
- 39	MS14046-1	96906	. TRANSFORMER, RF							1		PADZZ
- 40	JAN2N2907A	81349	. TRANSISTOR							1		PADZZ
- 41	CF07-153J	78488	. RESISTOR, FXD, COMP							3		PADZZ
- 42	CF07-272J	78488	. RESISTOR, FXD, COMP							1		PADZZ
- 43	CF07-473J	78488	. RESISTOR, FXD, COMP							5		PADZZ
- 44	RCR32G221JS	81349	. RESISTOR, FXD, COMP							1		PADZZ

Figure & Index Number	Part Number	FSCM	Description							Units Per Assy	Usable On Code	SMR Code
			1	2	3	4	5	6	7			
- 45	CF07-102J	78488	.	RESISTOR	,FXD	,COMP				8		PADZZ
- 46	RJR24FW502P	81349	.	RESISTOR	,VARIABLE					3		PADZZ
- 47	CF07-303J	78488	.	RESISTOR	,FXD	,COMP				1		PADZZ
- 48	CF07-392J	78488	.	RESISTOR	,FXD	,COMP				2		PADZZ
- 49	CF07-103J	78488	.	RESISTOR	,FXD	,COMP				13		PADZZ
- 50	CF07-183J	78488	.	RESISTOR	,FXD	,COMP				2		PADZZ
- 51	CF07-154J	78488	.	RESISTOR	,FXD	,COMP				2		PADZZ
- 52	CF07-223J	78488	.	RESISTOR	,FXD	,COMP				4		PADZZ
- 53	CF07-561J	78488	.	RESISTOR	,FXD	,COMP				1		PADZZ
- 54	3299W-1-502	57921	.	RESISTOR	,VARIABLE					3		PADZZ
- 55	4310R-101-103	32997	.	RESISTOR NETWORK						1		PADZZ
- 56	RNC55K1002FS	81349	.	RESISTOR	,FXD	,FILM				1		PADZZ
- 57	CF07-472J	78488	.	RESISTOR	,FXD	,COMP				2		PADZZ
- 58	RCR07G106JM	81349	.	RESISTOR	,FXD	,COMP				1		PADZZ
- 59	RNC55K1652FS	81349	.	RESISTOR	,FXD	,FILM				1		PADZZ
- 60	RNC55K3092FS	81349	.	RESISTOR	,FXD	,FILM				1		PADZZ
- 61	RNC55K7501FS	81349	.	RESISTOR	,FXD	,FILM				1		PADZZ
- 62	RNC55K4422FS	81349	.	RESISTOR	,FXD	,FILM				1		PADZZ
- 63	RNC55K9531FS	81349	.	RESISTOR	,FXD	,FILM				1		PADZZ
- 64	RNC55K3242FS	81349	.	RESISTOR	,FXD	,FILM				2		PADZZ
- 65	RNC55K1502FS	81349	.	RESISTOR	,FXD	,FILM				1		PADZZ
- 66	CF07-101J	78488	.	RESISTOR	,FXD	,COMP				7		PADZZ
- 67	CF07-104J	78488	.	RESISTOR	,FXD	,COMP				3		PADZZ
- 68	RN55D3242F	81349	.	RESISTOR	,FXD	,FILM				2		PADZZ
- 69	RN55K6812FS	81349	.	RESISTOR	,FXD	,FILM				2		PADZZ
- 70	RNC55K5622FS	81349	.	RESISTOR	,FXD	,FILM				1		PADZZ
- 71	RNC55K3162FS	81349	.	RESISTOR	,FXD	,FILM				1		PADZZ
- 72	RNC55K6042FS	81349	.	RESISTOR	,FXD	,FILM				1		PADZZ
- 73	RNC55K5492FS	81349	.	RESISTOR	,FXD	,FILM				1		PADZZ
- 74	RN55D6812F	81349	.	RESISTOR	,FXD	,FILM				2		PADZZ
- 75	RNC55K1473FS	81349	.	RESISTOR	,FXD	,FILM				1		PADZZ
- 76	RNC55K8252FS	81349	.	RESISTOR	,FXD	,FILM				1		PADZZ
- 77	CF07-222J	78488	.	RESISTOR	,FXD	,COMP				1		PADZZ
- 78	ERD50TJ101	54473	.	RESISTOR	,FXD	,COMP				1		PADZZ
- 79	CF07-203J	78488	.	RESISTOR	,FXD	,COMP				4		PADZZ
- 80	CF07-332J	78488	.	RESISTOR	,FXD	,COMP				1		PADZZ
- 81	CF07-333J	78488	.	RESISTOR	,FXD	,COMP				1		PADZZ
- 82	CF07-121J	78488	.	RESISTOR	,FXD	,COMP				1		PADZZ
- 83	RNC55K1962FS	81349	.	RESISTOR	,FXD	,FILM				1		PADZZ
- 84	RNC55K4421FS	81349	.	RESISTOR	,FXD	,FILM				1		PADZZ
- 85	RNC55K1821FS	81349	.	RESISTOR	,FXD	,FILM				1		PADZZ
- 86	RNC55K8251FS	81349	.	RESISTOR	,FXD	,FILM				1		PADZZ
- 87	RJR24FW503P	81349	.	RESISTOR	,VARIABLE					1		PADZZ
- 88	CF07-100J	78488	.	RESISTOR	,FXD	,COMP				1		PADZZ
- 89	RNC55K2493FS	81349	.	RESISTOR	,FXD	,FILM				1		PADZZ
- 90	105-0858-001	74970	.	JACK	,TIP					1		PADZZ
- 91	105-0852-001	74970	.	JACK	,TIP					1		PADZZ
- 92	1168004P6	94117	.	JACK	,TIP					1		PADZZ
- 93	351-8434-010	13499	.	MICROCIRCUIT						1		PADZZ
- 94	LM111J-8	27014	.	MICROCIRCUIT						2		PADZZ
- 95	7901401EB	14933	.	MICROCIRCUIT						2		PADZZ

Figure & Index Number	Part Number	FSCM	Description							Units Per Assy	Usable On Code	SMR Code									
			1	2	3	4	5	6	7												
- 96	M38510/17203BCB	81249	.	M	I	C	R	O	C	I	R	C	U	I	1	PADZZ					
- 97	TD8253	34649	.	M	I	C	R	O	C	I	R	C	U	I	1	PADZZ					
- 98	M38510/17103BCB	81349	.	M	I	C	R	O	C	I	R	C	U	I	1	PADZZ					
- 99	CD4011BD/3	02735	.	M	I	C	R	O	C	I	R	C	U	I	2	PADZZ					
-100	DS1692J	12040	.	M	I	C	R	O	C	I	R	C	U	I	1	PADZZ					
-101	UA9637ARM	07263	.	M	I	C	R	O	C	I	R	C	U	I	1	PADZZ					
-102	7901101CB	14933	.	M	I	C	R	O	C	I	R	C	U	I	1	PADZZ					
-103	CD4049UBF	02735	.	M	I	C	R	O	C	I	R	C	U	I	2	PADZZ					
-104	CD4051BD/3	02735	.	M	I	C	R	O	C	I	R	C	U	I	1	PADZZ					
-105	M38510/30701BEB	81349	.	M	I	C	R	O	C	I	R	C	U	I	1	PADZZ					
-106	CD4021BF	02735	.	M	I	C	R	O	C	I	R	C	U	I	1	PADZZ					
-107	CD4094BF	02735	.	M	I	C	R	O	C	I	R	C	U	I	3	PADZZ					
-108	M38510/32204BEB	81349	.	M	I	C	R	O	C	I	R	C	U	I	1	PADZZ					
-109	7704701EB	14933	.	M	I	C	R	O	C	I	R	C	U	I	1	PADZZ					
-110	CD4011BF	02735	.	M	I	C	R	O	C	I	R	C	U	I	2	PADZZ					
-111	M38510/10703BXC	81349	.	M	I	C	R	O	C	I	R	C	U	I	1	PADZZ					
-112	M38510/11502BXC	81349	.	M	I	C	R	O	C	I	R	C	U	I	1	PADZZ					
-113	524-AG11D	91506	.	S	O	C	K	E	T	P	L	U	G	I	N	E	L	E	C	1	PADZZ
-114	10085-6170	14304	.	O	S	C	I	L	A	T	O	R	,R	F	1	PADZZ					
-115	10085-6109	14304	.	P	W	B	,K	Y	/	C	O	N	V	,A	F	S	K	1	XA		
-116	6611-0135	14304	.	R	E	T	A	I	N	E	R	6	XB								
-117	10085-5156	14304	.	S	P	A	C	E	R	S	L	E	E	V	E	6	XB				
-118	MS35338-135	96906	.	W	A	S	H	E	R	L	O	C	6	PAOZZ							
-119	MS51957-17	96906	.	S	C	R	E	W	M	A	C	H	I	N	E	6	PAOZZ				

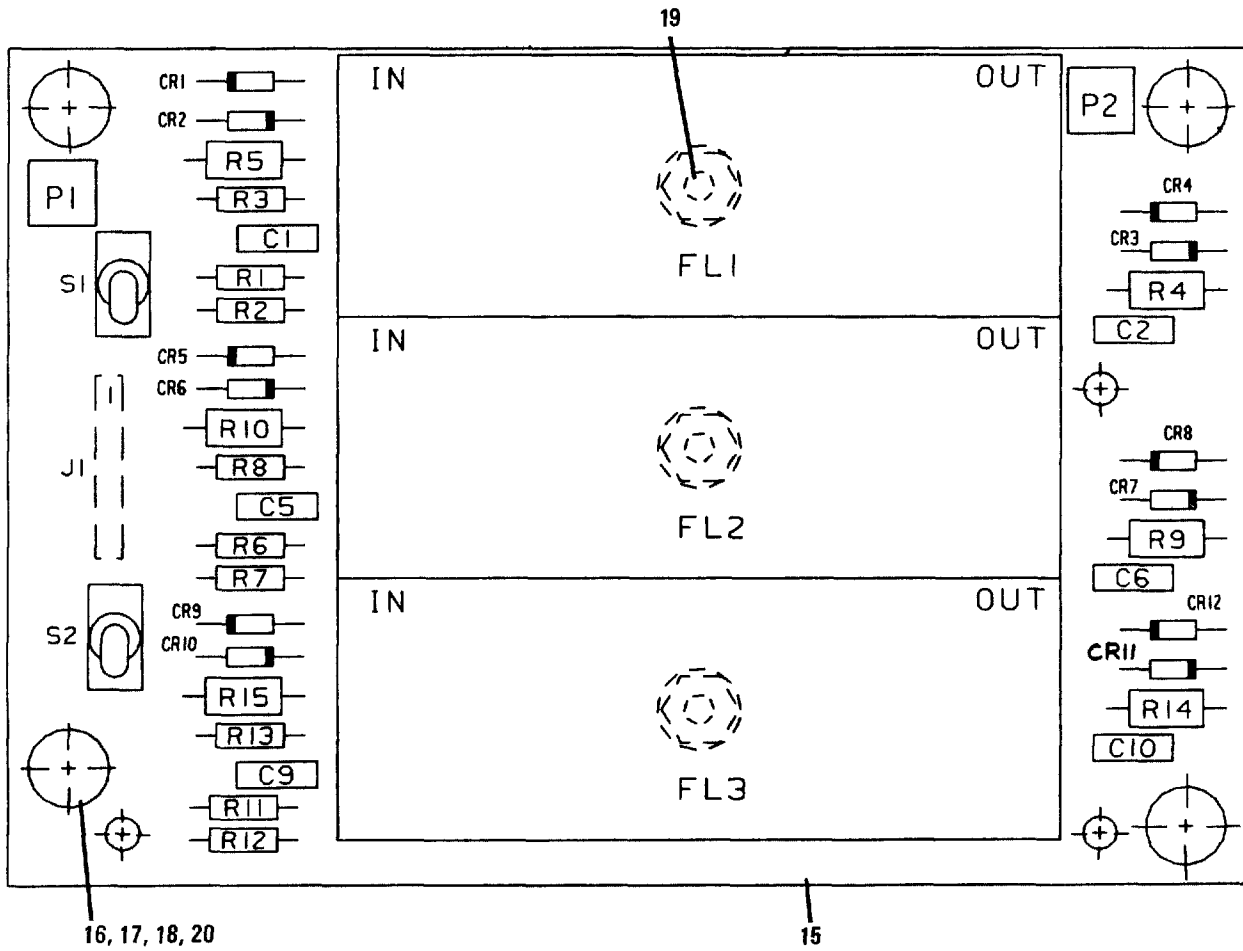
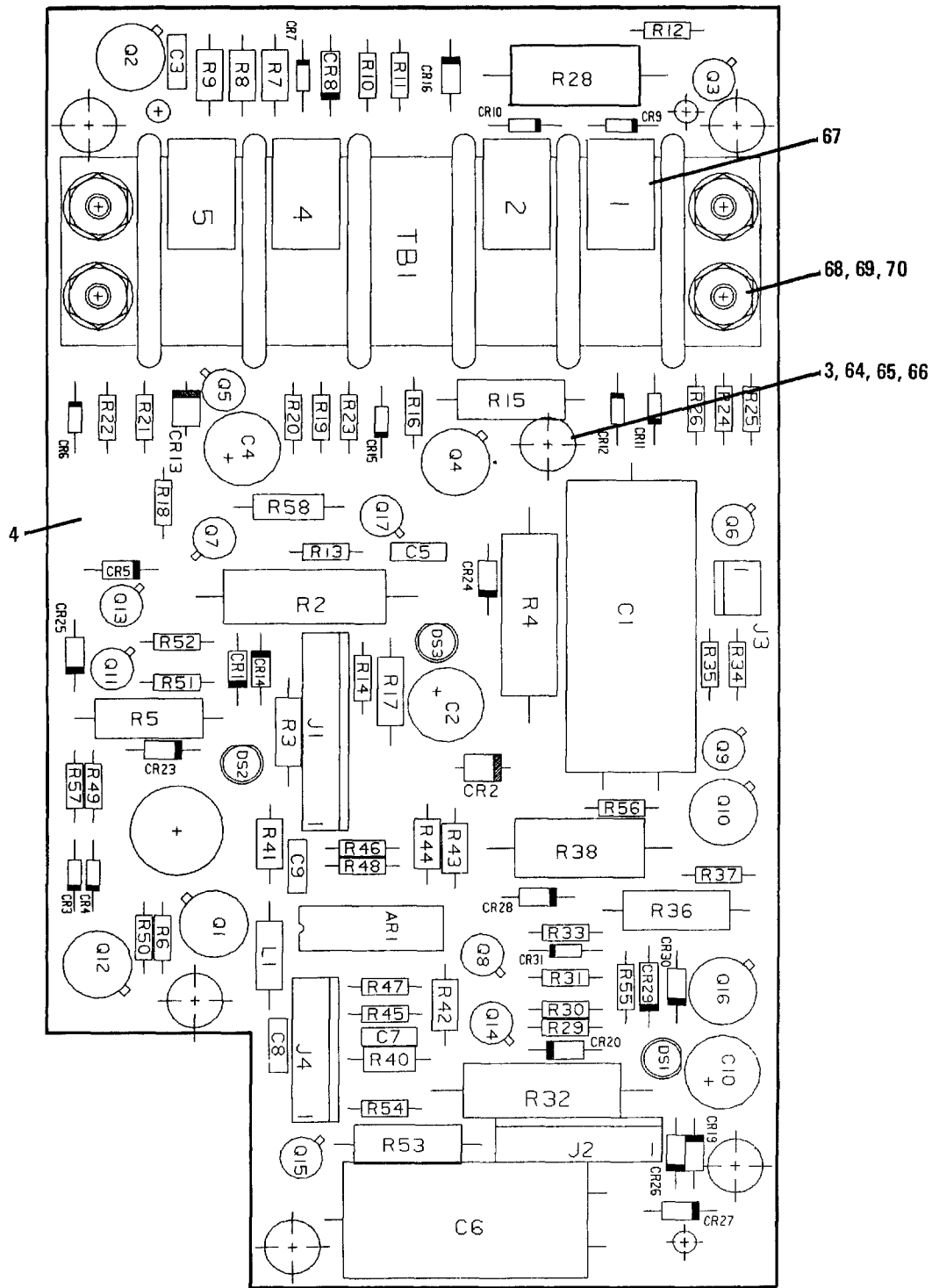

Figure 7-33. AFSK IF Filter PWB Assy, A1A18A2

## NOTE

To find index numbers for circuit board components, use the reference designator index at the end of this chapter. The complete reference designator for a circuit board component consists of "1," followed by the assembly designator (A1A1, A1A2, etc.), then the reference designator on the illustration. For example, the complete reference designator for R25 on the Exciter PWB Assy is 1A1A1 R25.

Figure & Index Number	Part Number	FSCM	Description							Units Per Assy	Usable On Code	SMR Code
			1	2	3	4	5	6	7			
7-33-	10085-6200	14304	IF/FLTR,AFSK ASSY,A1A18A2							1		XA
- 1	CK06BX474K	81349	. CAPACITOR, FXD, CER							6		PADZZ
- 2	JAN1N4454	81349	. SEMICONV DEVICE							12		PADZZ
- 3	10085-6120	14304	. FILTER,RF1							1		PADZZ
- 4	10085-6140	14304	. FILTER,RF1							1		PADZZ
- 5	10085-6160	14304	. FILTER,RF1							1		PADZZ
- 6	65507-107	22526	. CONNECTOR, PLUG, ELEC							1		PADZZ
- 7	CF07-101J	78488	. RESISTOR, FXD, COMP							3		PADZZ
- 8	CF07-102J	78488	. RESISTOR, FXD, COMP							3		PADZZ
- 9	CF07-222J	78488	. RESISTOR, FXD, COMP							3		PADZZ
- 10	RN55D1002F	81349	. RESISTOR, FXD, FILM							3		PADZZ
- 11	RNC55K5111FS	81349	. RESISTOR, FXD, FILM							3		PADZZ
- 12	RN55D5111F	81349	. RESISTOR, FXD, FILM							3		PADZZ
- 13	T103LH9V3BE	09353	. SWITCH TOGGLE							1		PADZZ
- 14	T101LH9V3BE	09353	. SWITCH TOGGLE							1		PADZZ
- 15	10085-6209	14304	. PWB, 1F/FLTR, AFSK							1		XA
- 16	10085-5156	14304	. SPACER SLEEVE							4		PADZZ
- 17	MS35338-135	96906	. WASHER LOCK							4		PADZZ
- 18	MS51957-17	96906	. SCREW MACHINE							4		PADZZ
- 19	H-6769	14304	. NUT, CLINCH							3		XB
- 20	6611-0135	14304	. RETAINER							4		PADZZ
- 21	51-328-3188-22G	98291	. CONNECTOR							2		PADZZ
- 22	D-607-09	06090	. CONTACT ELECT							2		PADZZ



350-133

Figure 7-34. Power Supply Protection and Control PWB Assy, A2A1



## NOTE

To find index numbers for circuit board components, use the reference designator index at the end of this chapter. The complete reference designator for a circuit board component consists of "1," followed by the assembly designator (A1A1, A1A2, etc.), then the reference designator on the illustration. For example, the complete reference designator for R25 on the Exciter PWB Assy is 1A1A1 R25.

Figure & Index Number	Part Number	FSCM	Description							Units Per Assy	Usable On Code	SMR Code
			1	2	3	4	5	6	7			
7-34-	10085-0290	14304	CIRCUIT CARD ASSY, A2A1							1		PAODD
- 1	LM2901F	18324	. MICROCIRCUIT							1		PADZZ
- 2	672D477H050FV5J	56289	. CAP, FXD, ELCTLT							1		PADZZ
- 3	10085-5156	14304	. BUSHING							6		PADZZ
- 4	10085-0299	14304	. CIRCUIT CARD							1		XA
- 5	672D476H040CD5C	56289	. CAP, FXD, ELCTLT							1		PADZZ
- 6	CK06BX104K	81349	. CAPACITOR, FXD, CER							5		PADZZ
- 7	672D686H025CD5C	56289	. CAP, FXD, ELCTLT							1		PADZZ
- 8	672D337H040ET5J	56289	. CAP, FXD, ELCTLT							1		PADZZ
- 9	SM-A-915742-1	80063	. CAP, FXD, ELCTLT							1		PADZZ
- 10	JAN1N3611	81349	. SEMICOND DEVICE, DIO							11		PADZZ
- 11	JAN1N5417	81349	. SEMICOND DEVICE, DIO							1		PADZZ
- 12	JAN1N4454	81349	. SEMICOND DEVICE, DIO							10		PADZZ
- 13	JAN1N752A	81349	. SEMICOND DEVICE, DIO							1		PADZZ
- 14	JAN1N759A	81349	. SEMICOND DEVICE, DIO							1		PADZZ
- 15	HLMP-3301	50434	. LED							1		PADZZ
- 16	1N5311	81349	. SEMICOND DEVICE, DIO							1		PADZZ
- 17	1N4738A	80131	. SEMICOND DEVICE, DIO							1		PADZZ
- 18	22-11-2112	27264	. CONNECTOR, RCPT, ELEC							1		PADZZ
- 19	22-11-2092	27264	. CONNECTOR, RCPT, ELEC							1		PADZZ
- 20	22-11-2032	27264	. CONN RECP ELECT							1		PADZZ
- 21	22-11-2082	27264	. CONNECTOR, RCPT, ELEC							1		PADZZ
- 22	MS90539-3	96906	. COIL, RF							1		PADZZ
- 23	JAN2N3439	81349	. TRANSISTOR							5		PADZZ
- 24	JAN2N2222A	81349	. TRANSISTOR							6		PADZZ
- 25	2N5859	80131	. TRANSISTOR							1		PADZZ
- 26	JAN2N2907A	81349	. TRANSISTOR							5		PADZZ
- 27	RW74U7OROF	81349	. RESISTOR, FXD, WW							1		PADZZ
- 28	ERD50TJ152	54473	. RESISTOR, FXD, COMP							1		PADZZ
- 29	RWR745R00FR	81349	. RESISTOR, FXD, WW							1		PADZZ
- 30	RCR32G332JS	81349	. RESISTOR, FXD, COMP							1		PADZZ
- 31	CF07-471J	78488	. RESISTOR, FXD, COMP							2		PADZZ
- 32	RN55D8451F	81349	. RESISTOR FXD FILM							1		PADZZ
- 33	RN55D4321F	81349	. RESISTOR, FXD, FILM							1		PADZZ
- 34	RN55D2001F	81349	. RESISTOR, FXD, FILM							1		PADZZ
- 35	CF07-101J	78488	. RESISTOR, FXD, COMP							2		PADZZ
- 36	CF07-102J	78488	. RESISTOR, FXD, COMP							7		PADZZ
- 37	CF07-273J	78488	. RESISTOR, FXD, COMP							2		PADZZ
- 38	CF07-390J	78488	. RESISTOR, FXD, COMP							1		PADZZ
- 39	RCR32G821JS	81349	. RESISTOR, FXD, COMP							1		PADZZ
- 40	ERD50TJ182	54473	. RESISTOR, FXD, COMP							1		PADZZ
- 41	CF07-472J	78488	. RESISTOR, FXD, COMP							2		PADZZ
- 42	CF07-470J	78488	. RESISTOR, FXD, COMP							2		PADZZ
- 43	CF07-103J	78488	. RESISTOR, FXD, COMP							6		PADZZ
- 44	CF07-222J	78488	. RESISTOR, FXD, COMP							2		PADZZ

Figure & Index Number	Part Number	FSCM	Description							Units Per Assy	Usable On Code	SMR Code
			1	2	3	4	5	6	7			
- 45	CF07-223J	78488	.							1		PADZZ
- 46	RCR42G100JM	81349	.							1		PADZZ
- 47	CF07-562J	78488	.							1		PADZZ
- 48	RWR74S1000FS	81349	.							1		PADZZ
- 49	CF07-393J	78488	.							1		PADZZ
- 50	CF07-272J	78488	.							1		PADZZ
- 51	RCR32G271JS	81349	.							1		PADZZ
- 52	CF07-221J	78488	.							1		PADZZ
- 53	RCR42G180JS	81349	.							1		PADZZ
- 54	RN55D4991F	81349	.							1		PADZZ
- 55	RN55D1002F	81349	.							1		PADZZ
- 56	RN55D3482F	81349	.							1		PADZZ
- 57	RN55D2002F	81349	.							2		PADZZ
- 58	CF07-105J	78488	.							2		PADZZ
- 59	CF07-512J	78488	.							1		PADZZ
- 60	CF07-561J	78488	.							1		PADZZ
- 61	RCR32G102JM	81349	.							1		PADZZ
- 62	ERD50TJ682	54473	.							1		PADZZ
- 63	39TB5	81349	.							1		PADZZ
- 64	6611-0135	14304	.							6		PADZZ
- 65	MS51957-17	96906	.							6		PADZZ
- 66	MS35338-135	96906	.							6		PADZZ
- 67	10085-0284	14304	.							4		XB
- 68	H-6767	14304	.							4		XB
- 69	MS51957-48	96906	.							4		PAOZZ
- 70	MS15795-807	96906	.							4		PADZZ



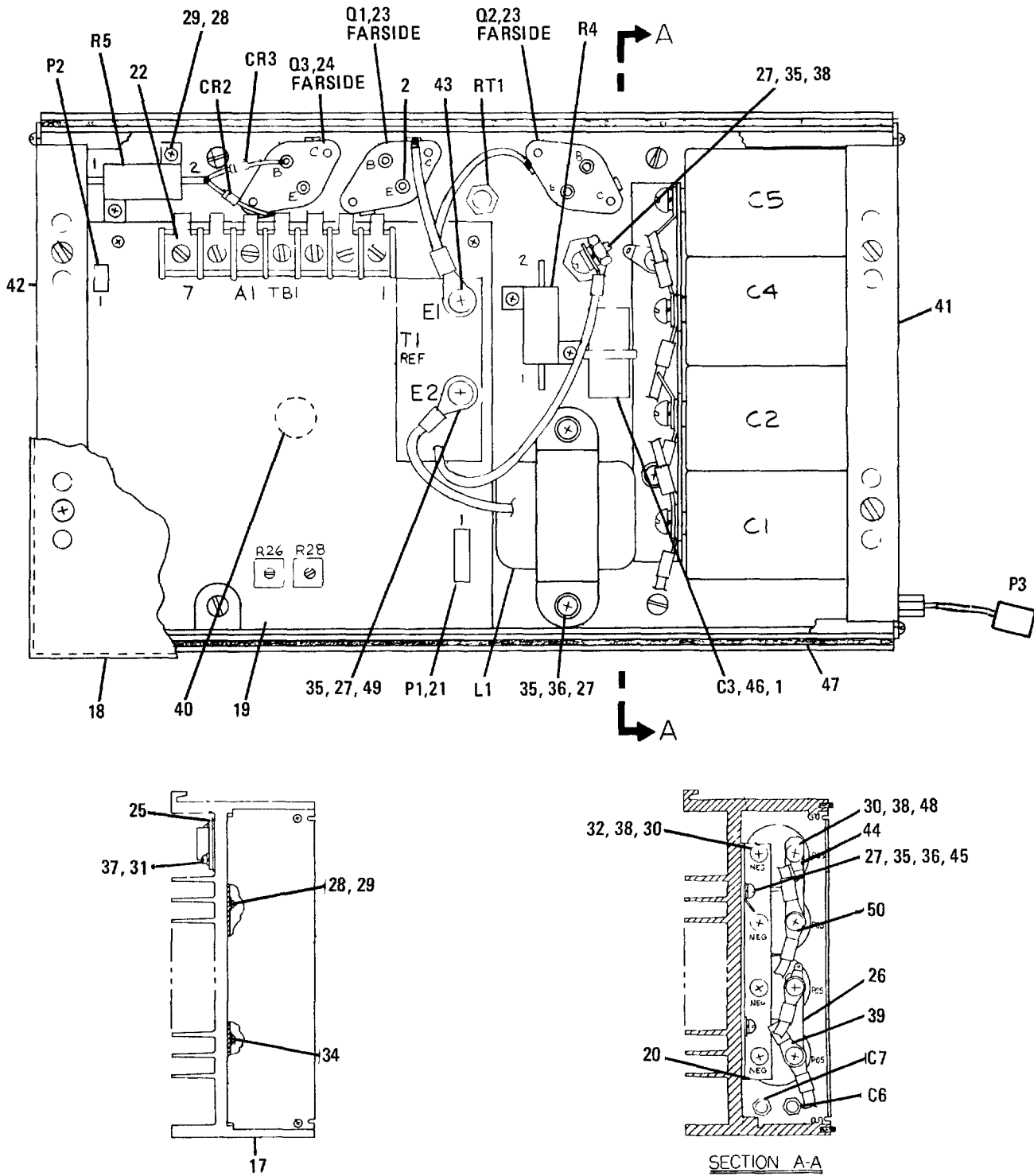

350-134

Figure 7-35. 13.6 V Power Supply, A2A2

## NOTE

To find index numbers for circuit board components, use the reference designator index at the end of this chapter. The complete reference designator for a circuit board component consists of "1," followed by the assembly designator (A1A1, A1A2, etc.), then the reference designator on the illustration. For example, the complete reference designator for R25 on the Exciter PWB Assy is 1A1A1 R25.

Figure & Index Number	Part Number	FSCM	Description							Units Per Assy	Usable On Code	SMR Code
			1	2	3	4	5	6	7			
7-35-	10085-0260	14304	POWER SUPPLY ASSY, A2A2							1		PAODD
- 1	MS3367-4-9	96906	. STRAP, TIE DOWN							8		PADZZ
- 2	M83519/1-2	81349	. SLEEVE, SOLDER							2		PADZZ
- 3	622D392M055AM2A	56289	. CAPACITOR, FXD							2		PADZZ
- 4	735P305X9100SLL	56289	. CAPACITOR, FXD, MYLAR							1		PADZZ
- 5	622D123M020AM2A	56289	. CAP, FXD, ELCTLT							2		PADZZ
- 6	2425003X5U152Z	56289	. CAPACITOR, FXD, CER							2		PADZZ
- 7	MR872R	04713	. SEMICOND DEVICE, DIO							1		PADZZ
- 8	JAN1N5417	81349	. SEMICOND DEVICE, DIO							2		PADZZ
- 9	10085-0266	14304	. COIL, RF							1		PADZZ
- 10	22-01-3087	27264	. CONNECTOR, PLUG, ELEC							3		PADZZ
- 11	22-01-3037	27264	. CONNECTOR, PLUG, ELEC							2		PADZZ
- 12	MJ14003	04713	. TRANSISTOR							2		PADZZ
- 13	2N5884	80131	. TRANSISTOR							1		PADZZ
- 14	RE70N13R7	81349	. RESISTOR, FXD							1		PADZZ
- 15	RE70N64R9	81349	. RESISTOR, FXD							1		PADZZ
- 16	10085-0254	14304	. RESISTOR, THERMAL							1		PAOZZ
- 17	10085-0259	14304	. HEATSINK							1		XB
- 18	10085-0263	14304	. COVER							1		XB
- 19	10085-0220	14304	. CIRCUIT CARD ASSY							1		PADLD
- 20	10085-0269	14304	. RETAINER							1		XB
- 21	08-56-0110	27264	. CONNECTOR, PLUG, ELEC							10		PADZZ
- 22	2-520182-4	00779	. CONTACT, ELEC							7		PADZZ
- 23	ST5M1554-001	76301	. SOCKET PLUGIN ELEC							2		PADZZ
- 24	374753-1	00752	. SOCKET PLUGIN ELEC							1		PADZZ
- 25	43-03-4	13103	. INSULATOR							3		PADZZ
- 26	10085-0255	14304	. CONTACT							2		XB
- 27	MS51957-43	96906	. SCREW, MACHINE (AP)							7		PAOZZ
- 28	MS51957-14	96906	. SCREW, MACHINE (AP)							4		PADZZ
- 29	MS35338-135	96906	. WASHER, SPLIT (AP)							4		PADZZ
- 30	MS51958-60	96906	. SCREW, MACHINE (AP)							8		PAOZZ
- 31	MS51957-31	96906	. SCREW, MACHINE (AP)							6		PAOZZ
- 32	MS15795-808	96906	. WASHER, FLAT (AP)							4		PADZZ
- 33	MS35338-138	96906	. WASHER, LOCK (AP)							8		PAOZZ
- 34	MS24630-10	96906	. SCREW, MACHINE (AP)							8		PAOZZ
- 35	MS35338-137	96906	. WASHER, LOCK (AP)							7		PAOZZ
- 36	MS15795-807	96906	. WASHER, FLAT (AP)							4		PADZZ
- 37	MS35338-136	96906	. WASHER, SPLIT (AP)							6		PADZZ
- 38	MS35649-284	96906	. NUT, PLAIN, HEX							1		PAOZZ
- 39	MS25036-108	96906	. TERMINAL, LUG							2		PADZZ
- 40	1546	06540	. BUMPER, RUBBER							1		XB
- 41	10085-0267	14304	. BRACKET							1		XB
- 42	10085-0277	14304	. BRACKET							1		XB
- 43	MS25036-153	96906	. TERMINAL, LUG							2		PADZZ
- 44	MS77068-4	96906	. LUG, SOLDER							2		PADZZ

Figure & Index Number	Part Number	FSCM	Description							Units Per Assy	Usable On Code	SMR Code
			1	2	3	4	5	6	7			
- 45	MS77068-3	96906	.	L	U	G				1	PADZZ	
- 46	TC-105A	59730	.	B	A	S	E			4	PADZZ	
- 47	O1-0101-0144	59950	.	G	A	S	K	E	T	23	XB	
- 48	MS35333-73	96906	.	W	A	S	H	E	R, L	6	PAOZZ	
- 49	MS25036-156	96906	.	T	E	R	M	I	N	1	PADZZ	
- 50	MS25036-112	96906	.	T	E	R	M	I	N	1	PADZZ	



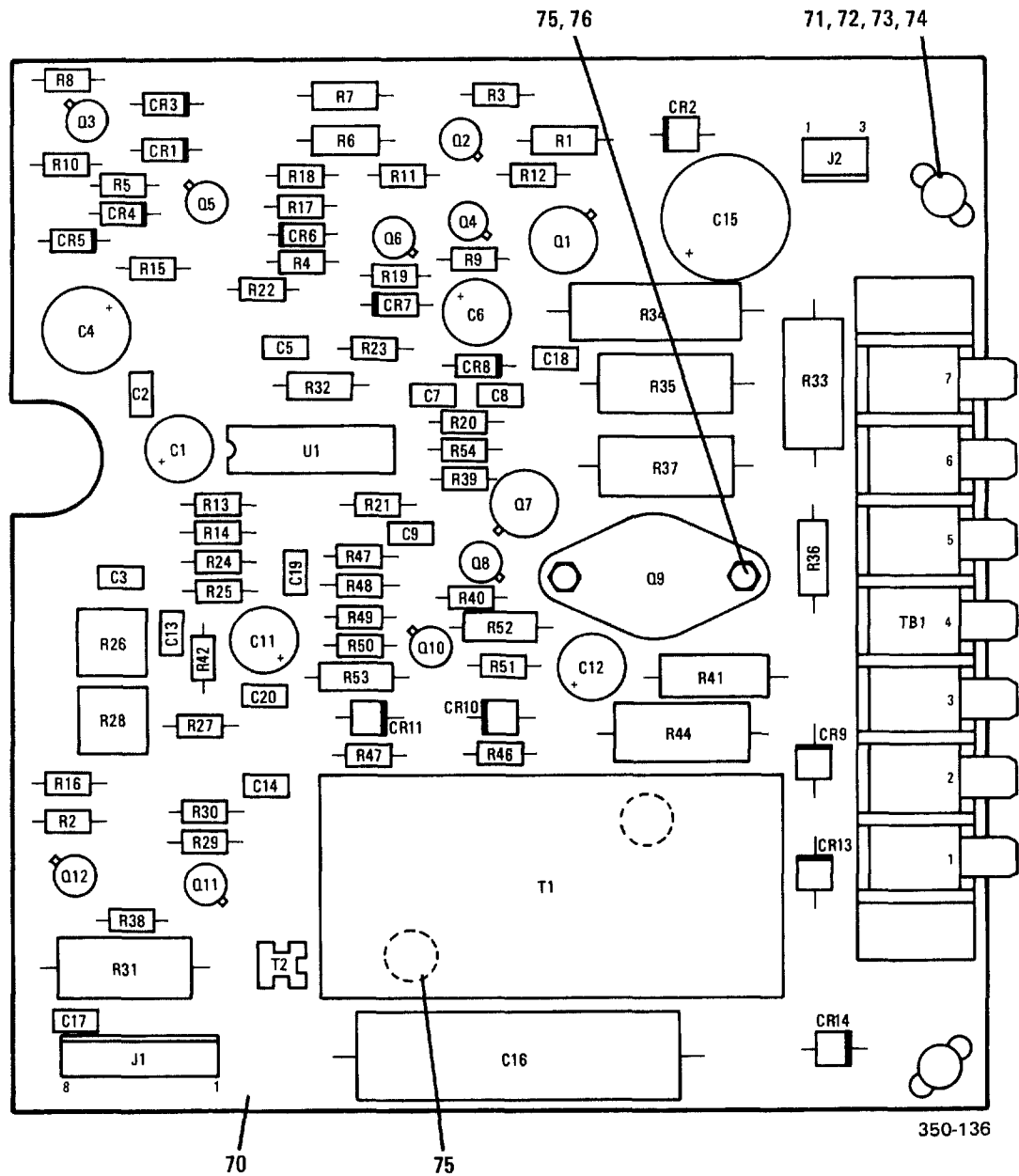

Figure 7-36. 13.6 V Power Supply PWB Assy, A2A2A1

(7-115 Blank)/7-116



## NOTE

To find index numbers for circuit board components, use the reference designator index at the end of this chapter. The complete reference designator for a circuit board component consists of "1," followed by the assembly designator (A1A1, A1A2, etc.), then the reference designator on the illustration. For example, the complete reference designator for R25 on the Exciter PWB Assy is 1A1A1 R25.

Figure & Index Number	Part Number	FSCM	Description 1 2 3 4 5 6 7	Units	Usable	SMR Code
				Per Assy	On Code	
7-36-	10085-0220	14304	CIRCUIT CARD ASSY, A2A2A1	1		PADLD
- 1	T392C106M025AS	31433	. CAP, FXD, ELCTLT	1		PADZZ
- 2	CK06BX104K	81349	. CAPACITOR, FXD, CER	6		PADZZ
- 3	672D476H040CD5C	56289	. CAP, FXD, ELCTLT	1		PADZZ
- 4	T392D476K010AS	31433	. CAP, FXD, ELCTLT	1		PADZZ
- 5	M39014/02-1326	81349	. CAPACITOR, FXD, CER	1		PADZZ
- 6	CK06BX473K	81349	. CAPACITOR, FXD, CER	2		PADZZ
- 7	CK06BX103K	81349	. CAPACITOR, FXD, CER	1		PADZZ
- 8	T392D226M025AS	31433	. CAP, FXD, ELCTLT	1		PADZZ
- 9	T392B335M025AS	31433	. CAP, FXD, ELCTLT	1		PADZZ
- 10	672D337H040ET50	56289	. CAP, FXD, ELCTLT	1		PADZZ
- 11	710P224X9200MQ	56289	. CAP, FXD, ELCTLT	1		PADZZ
- 12	CK05BX471K	81349	. CAPACITOR, FXD, CER	1		PADZZ
- 13	CK06BX474K	81349	. CAPACITOR, FXD, CER	1		PADZZ
- 14	1N4750A	80131	. SEMICOND DEVICE, DIO	1		PADZZ
- 15	JAN1N5417	81349	. SEMICOND DEVICE, DIO	6		PADZZ
- 16	1N4743A	81349	. SEMICOND DEVICE, DIO	1		PADZZ
- 17	JAN1N4454	81349	. SEMICOND DEVICE, DIO	5		PADZZ
- 18	22-11-2082	27264	. CONNECTOR, RCPT, ELEC	1		PADZZ
- 19	22-11-2032	27264	. CONN RECP ELECT	1		PADZZ
- 20	JAN2N3439	81349	. TRANSISTOR	2		PADZZ
- 21	JAN2N2907A	81349	. TRANSISTOR	4		PADZZ
- 22	JAN2N2222A	81349	. TRANSISTOR	5		PADZZ
- 23	2N6316	80131	. TRANSISTOR	1		PADZZ
- 24	ERD50TJ332	54473	. RESISTOR, FXD, COMP	1		PADZZ
- 25	CF07-182J	78488	. RESISTOR, FXD, COMP	2		PADZZ
- 26	RN55D4640F	81349	. RESISTOR, FXD, FILM	3		PADZZ
- 27	CF07-224J	78488	. RESISTOR, FXD, COMP	1		PADZZ
- 28	RNC60K1651FS	81349	. RESISTOR, FXD, FILM	1		PADZZ
- 29	CF07-103J	78488	. RESISTOR, FXD, COMP	1		PADZZ
- 30	ERD50TJ103	54473	. RESISTOR, FXD, COMP	1		PADZZ
- 31	CF07-472J	78488	. RESISTOR, FXD, COMP	3		PADZZ
- 32	CF07-682J	78488	. RESISTOR, FXD, COMP	1		PADZZ
- 33	CF07-271J	78488	. RESISTOR, FXD, COMP	1		PADZZ
- 34	RN55D1002F	81349	. RESISTOR, FXD, FILM	2		PADZZ
- 35	RNC55K1502FS	81349	. RESISTOR, FXD, FILM	1		PADZZ
- 36	RN55D4991F	81349	. RESISTOR, FXD, FILM	2		PADZZ
- 37	CF07-222J	78488	. RESISTOR, FXD, COMP	3		PADZZ
- 38	CF07-681J	78488	. RESISTOR, FXD, COMP	2		PADZZ
- 39	CF07-100J	78488	. RESISTOR, FXD, COMP	2		PADZZ
- 40	RNC55K2672FS	81349	. RESISTOR, FXD, FILM	1		PADZZ
- 41	RN55D5111F	81349	. RESISTOR, FXD, FILM	1		PADZZ
- 42	RN55D2491F	81349	. RESISTOR, FXD, FILM	1		PADZZ
- 43	3386F-1-202	32997	. RESISTOR, VARIABLE	1		PADZZ
- 44	RN55D3922F	81349	. RESISTOR, FXD, FILM	1		PADZZ

Figure & Index Number	Part Number	FSCM	Description							Units Per Assy	Usable On Code	SMR Code
			1	2	3	4	5	6	7			
- 45	3386F-1-104	32997	.	RESISTOR, VARIABLE						1		PADZZ
- 46	CF07-473J	78488	.	RESISTOR, FXD, COMP						2		PADZZ
- 47	RCR42G471JS	81349	.	RESISTOR, FXD, COMP						1		PADZZ
- 48	ERD50TJ272	54473	.	RESISTOR, FXD, COMP						1		PADZZ
- 49	RNC60H4993DS	81349	.	RESISTOR, FXD, COMP						1		PADZZ
- 50	FP67-6800HMPORM5PCT	24546	.	RESISTOR, FXD, COMP						1		PADZZ
- 51	RCR42G470JS	81349	.	RESISTOR, FXD, COMP						2		PADZZ
- 52	CF07-101J	78488	.	RESISTOR, FXD, COMP						1		PADZZ
- 53	ERD50TJ101	54473	.	RESISTOR, FXD, COMP						1		PADZZ
- 54	RCR42G681JS	81349	.	RESISTOR, FXD, COMP						1		PADZZ
- 55	CF07-153J	78488	.	RESISTOR, FXD, COMP						1		PADZZ
- 56	CF07-102J	78488	.	RESISTOR, FXD, COMP						1		PADZZ
- 57	CF07-221J	78488	.	RESISTOR, FXD, COMP						1		PADZZ
- 58	1240S-4,7-10	00213	.	RESISTOR, FXD, WW						1		PADZZ
- 59	RCR42G470JM	81349	.	RESISTOR, FXD, COMP						2		PADZZ
- 60	RN55D2150F	81349	.	RESISTOR, FXD, FILM						1		PADZZ
- 61	RN55D1001F	81349	.	RESISTOR, FXD, FILM						1		PADZZ
- 62	CF07-330J	78488	.	RESISTOR, FXD, COMP						1		PADZZ
- 63	RNC60K15ROFS	81349	.	RESISTOR, FXD, FILM						2		PADZZ
- 64	RN60D15ROF	81349	.	RESISTOR, FXD, FILM						2		PADZZ
- 65	3329H-1-201	32997	.	RESISTOR, VARIABLE						1		PADZZ
- 66	10085-0225	14304	.	TRANSFORMER, RF						1		PADZZ
- 67	10085-5014	14304	.	TRANSFORMER, RF						1		PADZZ
- 68	302207-B8	52458	.	TERMINAL						1		PADZZ
- 69	SG1524F	18324	.	MICROCIRCUIT						1		PADZZ
- 70	10085-0229	14304	.	CIRCUIT CARD						1		XA
- 71	6611-0135	14304	.	RETAINER, SCREW						2		PADZZ
- 72	10085-5156	14304	.	BUSHING						2		PADZZ
- 73	MS51957-17	96906	.	SCREW, MACHINE (AP)						2		PADZZ
- 74	MS35338-135	96906	.	WASHER, SPLIT (AP)						2		PADZZ
- 75	841-00	92967	.	NUT, CLINCH (AP)						4		PADZZ
- 76	MS51957-15	96906	.	SCREW, MACHINE (AP)						2		PADZZ

## Section III. NUMERICAL INDEX

Part Number	Fig No.	Index No.	Qty per End Item	Part Number	Fig No.	Index No.	Qty per End Item
ADC0808CCJ	7-25	42	1	CF07-183J	7-11	128	8
B25600F002	7-2	44	2	CF07-184J	7-15	57	3
B51547F013	7-2	46	2	CF07-201J	7-11	145	2
B51568F029	7-2	45	2	CF07-202J	7-11	144	1
C12-0001-003	7-20	8	1	CF07-203J	7-11	108	2
C13-0103-102	7-18	12	1	CF07-220J	7-11	152	14
C330C223J1G5CA	7-32	11	1	CF07-221J	7-11	137	23
C340C473J1G5CA	7-32	13	2	CF07-222J	7-11	80	46
C350C104J1G5CA	7-32	12	3	CF07-223J	7-11	97	19
C45-0002-621	7-15	15	1	CF07-224J	7-11	170	5
C45-0002-751	7-15	16	1	CF07-242J	7-11	112	4
C61-0002-003	7-22	2	1	CF07-270J	7-11	162	7
CA3028S	7-18	45	2	CF07-271J	7-11	172	5
CD19FC562J03	7-20	20	2	CF07-272J	7-12	34	16
CD4001BF	7-26	40	1	CF07-273J	7-11	83	20
CD4011BD/3	7-17	124	2	CF07-2R7J	7-18	112	5
CD4011BF	7-20	95	3	CF07-303J	7-32	47	1
CD4012BF	7-17	123	1	CF07-330J	7-20	80	2
CD4016BF	7-25	49	1	CF07-331J	7-11	168	6
CD4020BF	7-25	48	1	CF07-332J	7-11	84	12
CD4021BF	7-11	201	6	CF07-333J	7-11	92	18
CD4030BF	7-17	122	2	CF07-334J	7-11	153	5
CD4046BF	7-21	137	1	CF07-390J	7-34	38	1
CD4049UBF	7-32	103	2	CF07-391J	7-11	166	5
CD4051BD/3	7-32	104	1	CF07-392J	7-11	86	4
CD4053BF	7-11	189	2	CF07-393J	7-11	94	9
CD4094BF	7-11	200	16	CF07-3R3J	7-20	61	1
CD4516BF	7-17	120	2	CF07-3R9J	7-26	27	1
CD4536BF	7-17	119	1	CF07-470J	7-11	133	27
CDT. 22-35	7-18	37	2	CF07-471J	7-11	81	67
CF07-100J	7-13	105	18	CF07-472J	7-11	79	60
CF07-101J	7-11	102	57	CF07-473J	7-11	157	37
CF07-102J	7-11	89	99	CF07-474J	7-16	113	2
CF07-103J	7-11	85	163	CF07-4R7J	7-13	83	2
CF07-104J	7-11	93	59	CF07-510J	7-12	24	6
CF07-105J	7-15	56	8	CF07-511J	7-15	65	1
CF07-106J	7-21	109	1	CF07-512J	7-26	24	2
CF07-121J	7-17	103	3	CF07-513J	7-11	110	2
CF07-122J	7-11	104	15	CF07-560J	7-11	126	6
CF07-123J	7-11	141	4	CF07-561J	7-11	125	21
CF07-124J	7-18	128	1	CF07-562J	7-11	98	23
CF07-150J	7-18	90	2	CF07-563J	7-11	87	5
CF07-151J	7-11	88	10	CF07-620J	7-15	62	1
CF07-152J	7-11	113	11	CF07-680J	7-13	87	9
CF07-153J	7-11	82	17	CF07-681J	7-11	140	9
CF07-154J	7-11	177	4	CF07-682J	7-11	129	12
CF07-160J	7-20	82	1	CF07-683J	7-11	95	3
CF07-161J	7-15	63	2	CF07-6R8J	7-28	52	2
CF07-180J	7-20	63	5	CF07-750J	7-15	64	1
CF07-181J	7-15	47	6	CF07-751J	7-11	127	1
CF07-182J	7-11	161	12	CF07-820J	7-13	98	1

Part Number	Fig No.	Index No.	Qty per End Item	Part Number	Fig No.	Index No.	Qty per End Item
CF07-821J	7-11	130	15	CM06FD112J03	7-15	13	2
CF07-822J	7-11	109	6	CM06FD152J03	7-21	13	1
CF07-823J	7-20	85	1	CM06FD222J03	7-16	59	2
CF07-910J	7-15	35	1	CM06FD272J03	7-20	24	2
CK05BX100K	7-22	8	1	CM06FD392J03	7-32	20	2
CK05BX101K	7-18	13	3	CM06FD821J03	7-15	2	4
CK05BX102K	7-11	31	2	CMR05C100DODR	7-16	49	4
CK05BX151K	7-11	21	2	CMR05C150JODR	7-13	29	1
CK05BX181K	7-12	4	1	CMR05C150JODR	7-32	10	1
CK05BX221K	7-11	13	2	CMR05C5RODODR	7-16	46	2
CK05BX471K	7-16	56	4	CMR05E200JODR	7-11	39	1
CK06BX103K	7-11	22	2	CMR05E220JODR	7-18	19	1
CK06BX104K	7-11	15	2	CMR05E270GODR	7-13	10	5
CK06BX222K	7-18	40	2	CMR05E300GODR	7-16	33	3
CK06BX223K	7-18	21	4	CMR05E330GODR	7-11	34	6
CK06BX224K	7-11	12	2	CMR05E360GODR	7-13	9	3
CK06BX273K	7-28	24	3	CMR05E390GODR	7-16	43	5
CK06BX332K	7-28	23	3	CMR05E430GODR	7-16	36	8
CK06BX473K	7-36	6	4	CMR05E470GODR	7-16	34	7
CK06BX474K	7-11	14	2	CMR05E510GODR	7-18	16	2
CK06BX683K	7-20	12	4	CMR05E560GODR	7-13	14	9
CM05CD050D03	7-20	5	3	CMR05E680GODR	7-13	28	17
CM05CD100D03	7-16	50	2	CMR05E750GODR	7-13	21	4
CM05CD180J03	7-21	14	1	CMR05E820GODR	7-13	13	9
CM05ED270G03	7-13	18	2	CMR05F101GODR	7-13	11	5
CM05ED300G03	7-16	48	2	CMR05F111GODR	7-16	19	8
CM05ED330J03	7-11	36	2	CMR05F121GODR	7-15	6	6
CM05ED360J03	7-13	16	2	CMR05F131GODR	7-16	29	5
CM05ED390G03	7-16	44	2	CMR05F151GODR	7-16	9	6
CM05ED430G03	7-16	37	2	CMR05F161GODR	7-32	18	1
CM05ED470G03	7-16	35	2	CMR05F181GODR	7-16	10	9
CM05ED510G03	7-20	9	3	CMR05F201GODR	7-16	21	6
CM05ED560G03	7-16	27	4	CMR05F221GODR	7-16	22	7
CM05ED680G03	7-13	30	2	CMR05F241GODR	7-16	26	1
CM05ED750G03	7-16	38	5	CMR05F271GODR	7-13	19	2
CM05ED820G03	7-13	17	2	CMR05F301GODR	7-16	16	2
CM05FD101J03	7-13	15	2	CMR05F331GODR	7-32	21	1
CM05FD111G03	7-16	20	2	CMR05F391GODR	7-13	7	3
CM05FD121G03	7-16	32	7	CMR05F910GODR	7-13	12	3
CM05FD131G03	7-16	31	2	CMR06F102GODR	7-11	24	3
CM05FD151G03	7-16	30	2	CMR06F112GODR	7-18	23	3
CM05FD181G03	7-16	11	2	CMR06F122GODR	7-18	25	1
CM05FD201G03	7-16	24	2	CMR06F182GODR	7-32	17	1
CM05FD221G03	7-16	25	2	CMR06F222GODR	7-16	57	2
CM05FD271J03	7-13	20	2	CMR06F272GODP	7-20	21	2
CM05FD301G03	7-16	45	2	CMR06F362GODR	7-32	22	1
CM05FD331G03	7-15	1	8	CMR06F392GODR	7-32	15	3
CM05FD361G03	7-15	14	6	CMR06F431GODI	7-15	9	1
CM05FD391J03	7-15	4	3	CMR06F431GODR	7-32	24	1
CM05FD910G03	7-16	13	3	CMR06F432GODR	7-32	23	1
CM06FD102J03	7-11	28	2	CMR06F471GODR	7-21	17	1

Part Number	Fig No.	Index No.	Qty per End Item	Part Number	Fig No.	Index No.	Qty per End Item
CMR06F621GODR	7-20	13	1	G-12-A	7-6	1	1
CMR06F751GODR	7-20	23	1	GC283	7-4	4	1
CU31E600	7-16	5	1	H-0963	7-23	53	3
CV31B250	7-16	7	2	H-6767	7-34	68	6
CV31D350	7-20	19	1	H-6768	7-4	18	6
CV31E600	7-32	9	1	H-6769	7-12	45	3
D-607-09	7-33	22	2	H11L2	7-26	31	1
D20419-16	7-8	6	1	H408-1	7-3	4	8
D20419-16588D205-12	7-9	1	2	HKP-HH	7-6	19	1
DAC-08F	7-17	125	1	HLCDO438AY	7-24	6	5
DE24657	7-9	6	1	HLMP-3301	7-17	14	7
DM-15-18J	7-16	47	7	HLMP-3401	7-17	15	1
DM-15-20J	7-16	39	9	IM64021DL	7-26	36	1
DM-15-24J	7-16	41	6	J-0031	7-18	44	5
DM-15-250J	7-16	23	2	JAN1N3064	7-20	30	5
DM-15-500J	7-16	12	2	JAN1N3611	7-11	40	17
DM15F431-G	7-16	17	1	JAN1N4454	7-11	41	216
DM5416J	7-23	40	1	JAN1N4461	7-15	80	1
DR10DB229J	7-13	23	1	JAN1N4463	7-28	95	3
DR10DB569J	7-13	35	1	JAN1N5417	7-28	28	16
DR10DB689J	7-18	8	1	JAN1N5711	7-11	45	18
DR10DB829J	7-13	25	1	JAN1N748A	7-21	24	1
DS1692J	7-32	100	1	JAN1N750A	7-11	205	4
DS8629J-8	7-20	94	1	JAN1N751A	7-11	204	2
DV11PS15D	7-11	35	1	JAN1N752A	7-34	13	1
DV11PS25B	7-16	6	4	JAN1N759A	7-17	127	3
E312-E0001	7-23	38	1	JAN1N825	7-21	23	2
ERD50TJ100	7-25	33	3	JAN1N966B	7-17	126	1
ERD50TJ101	7-18	126	2	JAN2N2219A	7-11	72	5
ERD50TJ102	7-11	124	3	JAN2N2222A	7-11	71	92
ERD50TJ103	7-36	30	1	JAN2N2369A	7-11	73	7
ERD50TJ109	7-15	38	2	JAN2N2857	7-11	75	4
ERD50TJ121	7-15	37	1	JAN2N2907A	7-11	70	34
ERD50TJ122	7-29	34	1	JAN2N3439	7-13	74	10
ERD50TJ150	7-15	41	2	JAN2N3866A	7-13	76	5
ERD50TJ151	7-13	96	3	JAN2N4091	7-18	75	2
ERD50TJ152	7-34	28	1	JAN2N4957	7-21	42	3
ERD50TJ154	7-13	81	1	JAN2N5116	7-21	45	2
ERD50TJ182	7-34	40	1	JAN2N6338	7-28	39	2
ERD50TJ221	7-18	119	1	JAN2N6341	7-28	38	2
ERD50TJ270	7-15	39	1	K-0118	7-30	5	1
ERD50TJ271	7-15	45	4	KFB3-440-16ET	7-31	1	4
ERD50TJ272	7-36	48	1	KFB3-440-18ET	7-13	1	2
ERD50TJ331	7-17	89	2	KFB3-440-6-HS	7-31	7	4
ERD50TJ332	7-36	24	1	KFH-440-8	7-28	105	6
ERD50TJ479	7-15	46	2	KT45J3	7-16	124	1
ERD50TJ561	7-11	169	2	L-0254	7-13	51	1
ERD50TJ680	7-15	40	2	L-0255	7-13	50	2
ERD50TJ682	7-34	62	1	L-0256	7-20	37	1
FBT00-015	7-21	135	1	L11-0004-017	7-13	69	1
FP67-6800HMPORM5PCT	7-36	50	1	L13-0002-331	7-28	32	1

Part Number	Flg No.	Index No.	Qty per End Item	Part Number	Flg No.	Index No.	Qty per End Item
L13-0002-470	7-28	31	1	M39014/02-1344	7-28	7	1
LH0070-OH	7-11	202	1	M39014/02-1345	7-11	25	3
LM111J-8	7-32	94	2	M39014/02-1347	7-17	11	3
LM218J-8	7-32	1	1	M39014/02-1350	7-11	8	392
LM2901F	7-34	1	1	M39014/02-1352	7-20	11	2
LM2904N	7-15	77	1	M39014/02-1354	7-18	34	1
LT10K227	7-18	63	1	M39014/02-1356	7-11	9	8
M24308/1-1	7-9	5	1	M39014/02-1358	7-20	17	1
M24308/3-1	7-8	3	1	M39014/02-1360	7-11	11	79
M3850/30102BCB	7-20	97	6	M39014/02-1419	7-21	19	1
M38510/00206BCB	7-21	126	1	M39014102-1338	7-11	6	164
M38510/008021BCB	7-11	197	2	M83519/1-2	7-35	2	2
M38510/06101BEB	7-21	134	1	M85049/41-12A	7-9	10	2
M38510/07101BCB	7-21	131	2	MC12013L	7-20	92	2
M38510/10703BXC	7-22	42	2	MC145152L	7-20	90	1
M38510/11201BCB	7-25	45	1	MC1558U	7-11	3	48
M38510/11502BXC	7-32	112	1	MC1733L	7-16	3	3
M38510/17103BCB	7-32	98	1	MCM01-007EC670GO	7-16	51	2
M38510/17203BCB	7-32	96	1	MCM01-007FC1420GO	7-16	55	1
M38510/30003BCB	7-25	43	5	MD015E104MAA	7-23	1	17
M38510/30005BCB	7-26	34	1	MD918A	7-20	52	2
M38510/30106BEB	7-21	130	1	MDLSBL1	7-11	68	3
M38510/30301BCB	7-21	127	1	MJ14003	7-35	12	2
M38510/30501BCB	7-21	128	1	MM54C14J	7-11	195	1
M38510/30608BEB	7-23	35	3	MP-0745	7-23	52	2
M38510/30701BEB	7-11	198	6	MP-1142	7-11	56	15
M38510/30702BEB	7-25	39	2	MP150	7-25	69	1
M38510/31004BCB	7-25	41	2	MPS-A18	7-13	72	3
M38510/31005BCB	7-11	203	1	MPS-H34	7-21	47	9
M38510/31505BEA	7-20	93	2	MR5005R	7-14	7	1
M38510/32204BEB	7-11	199	4	MR826	7-29	2	1
M38510/32502BRW	7-25	37	1	MR872R	7-35	7	1
M39012/25-0006	7-6	21	1	MS-67-1-DC-WD	7-1	25	3
M39012/25-0011	7-6	20	1	MS14046-1	7-13	61	21
M39014/01-1330	7-11	19	1	MS14046-4	7-11	66	5
M39014/01-1339	7-11	30	4	MS14046-6	7-20	44	3
M39014/01-1342	7-11	20	2	MS14046-7	7-20	41	1
M39014/01-1345	7-11	10	7	MS14046-8	7-11	67	28
M39014/01-1351	7-11	32	8	MS15795-803	7-1	3	39
M39014/01-1357	7-11	29	32	MS15795-805	7-9	2	23
M39014/02-1322	7-18	27	1	MS15795-807	7-34	70	11
M39014/02-1326	7-36	5	3	MS15795-808	7-35	32	6
M39014/02-1329	7-18	29	2	MS16633-1025	7-1	7	2
M39014/02-1331	7-18	26	1	MS16995-10	7-14	22	9
M39014/02-1332	7-28	18	1	MS18130-11	7-13	49	2
M39014/02-1334	7-13	31	1	MS18130-14	7-13	64	1
M39014/02-1335	7-28	25	1	MS18130-15	7-13	59	1
M39014/02-1338	7-32	6	5	MS18130-2	7-18	52	1
M39014/02-1340	7-28	12	1	MS18130-5	7-11	62	4
M39014/02-1342	7-13	4	4	MS24630-10	7-35	34	8
M39014/02-1343	7-11	23	1	MS24693-C16	7-27	8	3

Part Number	Fig No.	Index No.	Qty per End Item	Part Number	Fig No.	Index No.	Qty per End Item
MS24693-C26	7-2	52	6	MS75083-8	7-13	63	1
MS24693-C272	7-3	13	4	MS75084-10	7-20	39	3
MS24693-C5	7-28	112	3	MS75084-12	7-16	91	9
MS25036-108	7-35	39	2	MS75084-16	7-18	53	1
MS25036-111	7-14	25	2	MS75084-3	7-11	64	4
MS25036-112	7-35	50	1	MS75085-19	7-26	10	6
MS25036-153	7-35	43	2	MS75085-2	7-26	9	11
MS25036-156	7-35	49	3	MS75087-5	7-13	52	1
MS3102A20-8P	7-2	16	3	MS75087-7	7-18	69	2
MS3102R20-27S	7-31	3	1	MS75089-10	7-18	65	1
MS3102R20-8P	7-6	17	2	MS75089-12	7-11	57	3
MS3106A20-8SC	7-9	9	2	MS75089-13	7-18	66	1
MS3367-4-9	7-16	2	48	MS75089-17	7-11	58	1
MS35333-70	7-14	3	12	MS77068-1	7-28	107	4
MS35333-72	7-15	86	1	MS77068-3	7-35	45	8
MS35333-73	7-35	48	8	MS77068-4	7-35	44	2
MS35333-76	7-23	54	3	MS90538-12	7-11	60	3
MS35338-134	7-3	2	12	MS90538-20	7-13	65	3
MS35338-135	7-11	212	10	MS90538-3	7-18	68	1
MS35338-136	7-9	3	45	MS90539-15	7-11	59	4
MS35338-137	7-35	35	7	MS90539-3	7-11	65	11
MS35338-138	7-35	33	12	MS90539-7	7-13	48	3
MS35489-4	7-11	210	6	MS90541-5	7-16	90	1
MS35649-244	7-18	154	8	MSD6150	7-11	42	1
MS35649-284	7-35	38	1	MSS-4200	7-30	11	2
MS51957-13	7-13	132	7	MV-309	7-20	29	2
MS51957-14	7-13	133	18	NE571N	7-11	190	3
MS51957-15	7-36	76	4	NT1-DC12V	7-16	68	14
MS51957-16	7-14	16	21	PN4917	7-21	43	9
MS51957-17	7-11	211	80	PT4371A	7-14	8	1
MS51957-18	7-1	4	2	PT4371B	7-14	9	1
MS51957-2	7-30	19	4	PT4371C	7-14	10	1
MS51957-28	7-9	4	19	QS200M36	7-2	48	1
MS51957-3	7-30	20	2	RCR07G106JM	7-32	58	1
MS51957-30	7-2	60	4	RCR32G100JS	7-2	22	1
MS51957-31	7-35	31	6	RCR32G102JM	7-34	61	3
MS51957-38	7-2	37	4	RCR32G102JS	7-28	43	2
MS51957-4	7-3	3	8	RCR32G151JM	7-13	114	2
MS51957-43	7-35	27	9	RCR32G151JS	7-13	113	2
MS51957-45	7-2	53	2	RCR32G221JS	7-32	44	1
MS51957-48	7-34	69	4	RCR32G271JS	7-34	51	1
MS51958-60	7-35	30	8	RCR32G332JS	7-34	30	1
MS51958-72	7-2	54	4	RCR32G820JS	7-13	110	1
MS75083-1	7-13	55	4	RCR32G821JS	7-34	39	1
MS75083-10	7-18	61	1	RCR42G100JM	7-15	44	2
MS75083-13	7-13	70	1	RCR42G100JS	7-15	43	5
MS75083-2	7-13	53	2	RCR42G102JS	7-2	21	1
MS75083-3	7-13	57	4	RCR42G103JS	7-16	120	1
MS75083-5	7-13	54	2	RCR42G180JS	7-34	53	1
MS75083-6	7-13	66	3	RCR42G221JS	7-28	44	1
MS75083-7	7-11	63	3	RCR42G470JM	7-36	59	2

PART NUMBER	FIG NO.	INDEX NO.	QTY PER END ITEM
RCR42G470JS	7-36	51	2
RCR42G471JS	7-36	47	1
RCR42G681JS	7-36	54	1
RE70N13R7	7-35	14	1
RE70N64R9	7-35	15	1
RER75F1ROOR	7-2	23	1
RJR24FW202P	7-16	111	2
RJR24FW502D	7-25	16	1
RJR24FW502P	7-32	46	3
RJR24FW503P	7-11	122	2
RLR20C22R1FS	7-28	75	1
RN55D1000F	7-11	117	2
RN55D1001F	7-11	118	2
RN55D1002F	7-12	28	6
RN55D1003F	7-17	30	2
RN55D1004F	7-11	105	2
RN55D1151F	7-11	181	2
RN55D1212F	7-17	55	5
RN55D1331F	7-21	71	2
RN55D1332F	7-17	77	3
RN55D1402F	7-17	88	2
RN55D1472F	7-21	91	2
RN55D1503F	7-11	151	2
RN55D1652F	7-17	73	3
RN55D1821F	7-17	105	3
RN55D1824F	7-17	82	1
RN55D1961F	7-21	95	2
RN55D2001F	7-11	132	2
RN55D2002F	7-25	17	4
RN55D2004F	7-11	107	2
RN55D2150F	7-36	60	3
RN55D2210F	7-22	29	3
RN55D2211F	7-17	48	6
RN55D2431F	7-13	101	3
RN55D2432F	7-17	38	5
RN55D2491F	7-36	42	3
RN55D27R4F	7-18	78	3
RN55D3010F	7-11	160	2
RN55D3011F	7-11	121	2
RN55D3242F	7-32	68	2
RN55D3321F	7-20	71	3
RN55D3322F	7-17	39	5
RN55D3323F	7-17	29	3
RN55D3482F	7-34	56	3
RN55D3510F	7-11	146	2
RN55D3831F	7-21	105	2
RN55D3922F	7-36	44	3
RN55D39R2F	7-11	164	2
RN55D4320F	7-11	179	2
RN55D4321F	7-34	33	3
RN55D4422F	7-17	40	4

PART NUMBER	FIG NO.	INDEX NO.	QTY PER END ITEM
RN55D4640F	7-36	26	5
RN55D4750F	7-28	73	3
RN55D4751F	7-17	76	2
RN55D4990F	7-28	80	3
RN55D4991F	7-17	106	2
RN55D5110F	7-21	98	2
RN55D5111F	7-12	29	2
RN55D5620F	7-11	165	2
RN55D5901F	7-17	79	2
RN55D6040F	7-11	91	7
RN55D6190F	7-21	89	2
RN55D6810F	7-20	69	2
RN55D6811F	7-22	27	3
RN55D6812F	7-11	149	8
RN55D6980F	7-13	102	3
RN55D7501F	7-17	85	3
RN55D8250F	7-21	96	2
RN55D8251F	7-16	114	3
RN55D8451F	7-34	32	3
RN55D8R25F	7-28	78	1
RN55D9093F	7-21	108	1
RN55K2491FS	7-28	48	2
RN55K4320FS	7-11	178	2
RN55K6812FS	7-32	69	2
RN60D15R0F	7-36	64	2
RN60D3010F	7-30	9	2
RN60D56R2F	7-16	109	2
RNC55K1000FS	7-11	115	10
RNC55K1001FS	7-11	114	8
RNC55K1002FS	7-11	176	35
RNC55K1003FS	7-17	26	7
RNC55K1004FS	7-11	99	4
RNC55K1100FS	7-11	131	1
RNC55K1102FS	7-28	59	1
RNC55K1151FS	7-11	180	2
RNC55K1152FS	7-28	47	1
RNC55K1212RS	7-16	112	6
RNC55K1302FS	7-17	92	1
RNC55K1303FS	7-17	99	1
RNC55K1331RS	7-21	70	2
RNC55K1332FS	7-11	175	3
RNC55K1372FS	7-11	174	1
RNC55K1402FS	7-17	35	2
RNC55K1472FS	7-21	86	2
RNC55K1473FS	7-32	75	1
RNC55K1501FS	7-21	75	1
RNC55K1502FS	7-36	35	1
RNC55K1503FS	7-11	147	3
RNC55K1622FS	7-17	91	1
RNC55K1652FS	7-11	150	2
RNC55K1743FS	7-17	94	1



Part Number	Fig No.	Index No.	Qty per End Item	Part Number	Fig No.	Index No.	Qty per End Item
RNC55K1781FS	7-21	77	1	RNC55K5110FS	7-21	97	2
RNC55K1782FS	7-17	52	1	RNC55K5111FS	7-12	27	7
RNC55K1820FS	7-18	83	1	RNC55K5112FS	7-17	53	1
RNC55K1821FS	7-13	99	3	RNC55K5231FS	7-12	22	1
RNC55K1822FS	7-17	96	1	RNC55K5232FS	7-17	90	1
RNC55K1960FS	7-21	79	1	RNC55K5492FS	7-32	73	1
RNC55K1961FS	7-21	88	6	RNC55K5620FS	7-11	134	2
RNC55K1962FS	7-32	83	1	RNC55K5622FS	7-17	100	1
RNC55K2000FS	7-11	142	1	RNC55K5761FS	7-16	119	1
RNC55K2001FS	7-11	116	5	RNC55K5901FS	7-17	51	3
RNC55K2002FS	7-17	72	5	RNC55K6042FS	7-32	72	1
RNC55K2003FS	7-28	64	1	RNC55K6190FS	7-21	82	2
RNC55K2150FS	7-28	72	2	RNC55K6191FS	7-17	45	1
RNC55K2151FS	7-21	92	1	RNC55K6192FS	7-17	93	1
RNC55K2210FS	7-17	65	2	RNC55K6810FS	7-20	68	8
RNC55K2211FS	7-12	23	9	RNC55K6811FS	7-17	47	8
RNC55K2212FS	7-13	115	1	RNC55K68R1FS	7-11	143	1
RNC55K2263FS	7-17	81	1	RNC55K6980FS	7-11	159	4
RNC55K2431FS	7-11	158	3	RNC55K7501FS	7-11	155	3
RNC55K2432FS	7-11	100	4	RNC55K75R0FS	7-11	136	1
RNC55K2493FS	7-32	89	1	RNC55K8061FS	7-28	63	1
RNC55K2671FS	7-17	41	1	RNC55K8250FS	7-21	78	3
RNC55K2672FS	7-36	40	1	RNC55K8251FS	7-13	112	3
RNC55K2742FS	7-17	31	1	RNC55K8252FS	7-32	76	1
RNC55K27R4FS	7-13	100	2	RNC55K8451FS	7-22	28	2
RNC55K2870FS	7-21	90	1	RNC55K9090FS	7-17	101	1
RNC55K3010FS	7-11	101	4	RNC55K9091FS	7-20	70	1
RNC55K3011FS	7-11	120	2	RNC55K9531FS	7-32	63	1
RNC55K3092FS	7-32	60	1	RNC60H4993DS	7-36	49	1
RNC55K3162FS	7-17	43	1	RNC60K15R0FS	7-36	63	2
RNC55K3242FS	7-32	64	2	RNC60K1651FS	7-36	28	1
RNC55K3321FS	7-17	56	3	RNC60K23R7FS	7-28	71	1
RNC55K3322FS	7-11	154	5	RNC60K3010FS	7-30	8	4
RNC55K3481FS	7-21	81	1	RNC60K56R2FS	7-16	108	2
RNC55K3482FS	7-11	173	2	RSF-1A	7-15	42	5
RNC55K3831FS	7-21	104	3	RUR-D820	7-28	29	1
RNC55K3922FS	7-11	156	2	RW74U6R49F	7-23	29	1
RNC55K39R2FS	7-11	135	2	RW74U7OROF	7-34	27	1
RNC55K4021FS	7-11	167	1	RWR745R00FR	7-34	29	1
RNC55K4122FS	7-17	97	1	RWR74S1000FS	7-34	48	1
RNC55K4221FS	7-21	111	1	SA571F	7-11	191	4
RNC55K4321FS	7-11	106	2	SA572F	7-11	193	1
RNC55K4322FS	7-11	148	1	SBL-1	7-18	139	4
RNC55K4421FS	7-32	84	1	SE-54	7-15	85	1
RNC55K4422FS	7-32	62	1	SE5561FE	7-28	93	1
RNC55K4640FS	7-28	77	4	SEPX-12	7-30	13	1
RNC55K4750FS	7-18	98	2	SG1524F	7-28	92	2
RNC55K4751FS	7-17	75	3	SM-66-52-14	7-28	103	3
RNC55K47R5FS	7-11	163	1	SM-A-915742-1	7-34	9	1
RNC55K4990FS	7-22	26	2	SN5416J	7-26	32	3
RNC55K4991FS	7-17	74	7	SN54LS00J	7-20	91	5

Part Number	Fig No.	Index No.	Qty per End Item	Part Number	Fig No.	Index No.	Qty per End Item
SN54LS04J	7-25	44	2	TAPF3.3M25	7-13	34	2
SN54LS08J	7-25	62	2	TC-105A	7-4	20	13
SN54LS109AJ	7-21	133	1	TC5516APL	7-25	51	2
SN54LS138J	7-18	144	3	TD271-28-4	7-25	84	3
SN54LS139J	7-25	60	2	TD8088	7-25	36	1
SN54LS161AJ	7-25	46	1	TD8253	7-32	97	1
SN54LS165J	7-25	50	4	TD8255A	7-25	59	1
SN54LS168AJ	7-21	124	3	TD8259A	7-25	55	1
SN54LS192J	7-21	125	2	TDA2002H	7-18	4	1
SN54LS244J	7-25	54	1	TIP120	7-14	12	3
SN54LS245J	7-25	52	2	TLO71MJG	7-11	2	7
SN54LS26J	7-11	187	1	TPA11FG-RA6	7-25	35	1
SN54LS299J	7-25	58	1	TY-304P	7-11	182	1
SN54LS367AJ	7-23	37	4	U309	7-21	44	2
SN54LS368AJ	7-18	143	3	U310	7-11	77	2
SN54LS390J	7-20	96	2	U6A7733312	7-13	3	2
SN54LS393J	7-26	38	1	UA78M05HM	7-25	66	3
SN54LS74AJ	7-21	129	3	UA78M12HM	7-23	42	3
SN54LS92J	7-25	47	1	UA9637ARM	7-32	101	1
SN54S74J	7-21	132	2	UES1103	7-13	37	4
ST5M1554-001	7-35	23	2	ULQ-2003R	7-11	192	2
T-2220	7-30	12	4	UM9301	7-11	46	10
T04/43	7-25	1	1	V275LA40A	7-2	28	2
T101LH9V3BE	7-12	38	1	VHE1402	7-28	30	1
T103LH9V3BE	7-33	13	1	VK200-20/4B	7-21	30	3
T2106	7-18	137	1	W199SDX-2	7-2	18	1
T392B106K010AS	7-11	37	11	W199SDX-3	7-2	19	1
T392B106M010AS	7-11	38	2	W58XB1A6A-6	7-2	12	2
T392B155K035AS	7-11	16	11	X440,.01,107,50	7-21	11	1
T392B155M035AS	7-11	17	2	ZX-4464 30DURO	7-2	50	22
T392B225K025AS	7-18	10	2	01-0101-0144	7-35	47	23
T392B225M025AS	7-18	11	2	010440B062	7-23	49	4
T392B335K025AS	7-11	4	38	010440B112	7-28	109	3
T392B335M025AS	7-11	7	2	0180-2827	7-28	9	4
T392C106M025AS	7-11	5	58	028868	7-2	9	1
T392C226M010AS	7-13	8	3	0736-7232	7-24	1	2
T392C335M035AS	7-18	31	3	08-56-0110	7-17	21	68
T392C475K025AS	7-11	33	1	0831000C0G0120G	7-16	53	1
T392D226K025AS	7-11	26	4	0N947	7-13	78	7
T392D226M025AS	7-11	27	2	10018550-104	7-6	16	1
T392D476K010AS	7-36	4	1	10029-0073	7-2	49	1
T392D686K010AS	7-21	18	1	10029-0211	7-15	67	4
T392E476K025AS	7-25	5	2	10073-3051	7-29	13	1
T392E476M025AS	7-25	7	2	10073-7002	7-22	39	1
T392F157K010AS	7-25	4	5	10073-7003	7-20	86	1
T392F157M010AS	7-25	6	2	10073-7014	7-22	41	2
T392F157M016AS	7-18	33	1	10073-7034	7-25	14	3
T392F686M025AS	7-11	18	5	10077	7-16	70	1
TAPF10K50	7-18	38	1	10078	7-16	71	1
TAPF10M25	7-13	36	4	10079	7-16	73	1
TAPF3.3K25	7-13	33	2	10080	7-16	74	1
				10081	7-16	75	1

Part Number	Fig No.	Index No.	Qty per End Item	Part Number	Fig No.	Index No.	Qty per End Item
10082	7-16	76	1	10085-0300-13	7-7	16	1
10083	7-16	77	1	10085-0303	7-20	46	1
10084	7-16	78	1	10085-0322	7-10	1	1
10085-0008	7-1	2	1	10085-0324	7-10	2	1
10085-0010	7-1	6	1	10085-0327	7-18	70	1
10085-0060	7-9	0	1	10085-0328	7-20	45	1
10085-0065	7-9	8	1	10085-0329	7-10	5	1
10085-0066	7-9	11	1	10085-0330	7-10	6	1
10085-0067	7-9	12	1	10085-0332	7-29	14	1
10085-0068	7-9	13	1	10085-0333	7-29	15	1
10085-0071	7-1	5	1	10085-0334	7-29	16	1
10085-0079	7-2	1	1	10085-0337	7-29	17	1
10085-0100	7-1	11	1	10085-0338	7-29	18	1
10085-0105	7-1	29	1	10085-0339	7-29	19	1
10085-0204	7-2	17	1	10085-0340	7-29	20	1
10085-0205	7-2	32	1	10085-0341	7-29	22	1
10085-0213	7-2	26	1	10085-0342	7-29	23	1
10085-0220	7-35	19	1	10085-0343	7-29	24	1
10085-0225	7-36	66	1	10085-0346	7-10	3	1
10085-0229	7-36	70	1	10085-0347	7-31	5	1
10085-0249	7-2	36	1	10085-0350	7-15	28	1
10085-0250	7-2	4	1	10085-0500	7-3	16	1
10085-0252	7-2	42	1	10085-0510	7-5	11	1
10085-0254	7-35	16	2	10085-0516	7-3	15	1
10085-0255	7-35	26	2	10085-0521	7-6	8	1
10085-0257	7-2	34	1	10085-0522	7-1	8	1
10085-0259	7-35	17	1	10085-0523	7-1	9	1
10085-0260	7-2	7	1	10085-0524	7-1	10	2
10085-0262	7-2	33	1	10085-0525	7-6	3	1
10085-0263	7-35	18	1	10085-0526	7-6	4	1
10085-0264	7-2	35	1	10085-0527	7-5	2	1
10085-0266	7-35	9	1	10085-0528	7-1	12	1
10085-0267	7-35	41	1	10085-0529	7-1	13	1
10085-0269	7-35	20	1	10085-0530	7-1	14	10
10085-0270	7-2	31	1	10085-0535	7-3	1	4
10085-0271	7-1	28	1	10085-0550	7-6	6	1
10085-0273	7-2	56	1	10085-0559	7-31	6	1
10085-0277	7-35	42	1	10085-0570	7-6	5	1
10085-0278	7-2	43	2	10085-0576	7-30	15	1
10085-0284	7-34	67	4	10085-0577	7-30	16	1
10085-0290	7-2	6	1	10085-0578	7-30	22	1
10085-0299	7-34	4	1	10085-0579	7-30	14	1
10085-0300-01	7-7	1	1	10085-0580	7-6	7	1
10085-0300-02	7-7	4	1	10085-0610	7-5	6	1
10085-0300-03	7-7	6	1	10085-0611	7-19	2	1
10085-0300-04	7-7	7	1	10085-1209	7-27	3	1
10085-0300-05	7-7	8	1	10085-1224	7-28	88	1
10085-0300-06	7-7	9	1	10085-1225	7-28	90	1
10085-0300-07	7-7	10	1	10085-1228	7-28	33	1
10085-0300-08	7-7	13	1	10085-1230	7-27	6	1
10085-0300-09	7-7	15	1	10085-1240	7-5	8	1

Part Number	Fig No.	Index No.	Qty per End Item	Part Number	Fig No.	Index No.	Qty per End Item
10085-1245	7-28	98	1	10085-5129	7-2	5	1
10085-1247	7-27	5	1	10085-5131	7-13	134	12
10085-1260	7-27	4	1	10085-5136	7-24	9	4
10085-1266	7-28	91	1	10085-5139	7-1	27	2
10085-1268	7-28	34	1	10085-5143	7-1	15	1
10085-1269	7-28	97	1	10085-5144	7-8	5	1
10085-2000	7-4	0	1	10085-5155	7-18	152	1
10085-2007	7-1	22	1	10085-5156	7-11	209	87
10085-2017	7-1	21	1	10085-5157	7-5	1	2
10085-2019	7-4	11	1	10085-5159	7-1	16	2
10085-2100	7-4	1	1	10085-5161	7-13	2	1
10085-2105	7-23	44	1	10085-5162	7-20	3	1
10085-2109	7-23	43	1	10085-5163	7-21	2	1
10085-2110	7-4	2	1	10085-5164	7-18	153	1
10085-2112	7-24	8	2	10085-5165	7-11	1	1
10085-2113	7-23	18	1	10085-5171	7-3	5	1
10085-2120	7-24	3	1	10085-5172	7-3	6	1
10085-2129	7-24	7	1	10085-5173	7-3	7	1
10085-2141	7-23	23	1	10085-5174	7-1	17	1
10085-2142	7-23	25	1	10085-5175	7-1	18	1
10085-2143	7-23	24	1	10085-5180	7-14	6	1
10085-2144	7-23	15	1	10085-5200	7-1	20	1
10085-4000	7-5	5	1	10085-5209	7-18	147	1
10085-4009	7-16	131	1	10085-5212	7-18	67	1
10085-4010	7-16	125	1	10085-5250	7-3	9	1
10085-4020	7-16	88	2	10085-5259	7-17	128	1
10085-4022	7-16	92	1	10085-5300	7-5	3	1
10085-4030	7-16	79	1	10085-5309	7-12	40	1
10085-4031	7-16	80	1	10085-5321	7-12	8	1
10085-4032	7-16	81	1	10085-5331	7-12	7	1
10085-4033	7-16	85	1	10085-5340	7-12	9	1
10085-4034	7-16	86	1	10085-5400	7-1	19	1
10085-4035	7-16	87	1	10085-5409	7-11	207	1
10085-4210	7-5	9	1	10085-5425	7-11	206	2
10085-4219	7-29	39	1	10085-5500	7-3	10	1
10085-5000	7-3	8	1	10085-5506	7-20	38	1
10085-5009	7-13	123	1	10085-5509	7-20	98	1
10085-5012	7-13	32	1	10085-5600	7-3	11	1
10085-5013	7-13	117	1	10085-5609	7-21	139	1
10085-5014	7-13	121	2	10085-5610	7-21	136	1
10085-5016	7-13	131	1	10085-5611	7-22	40	1
10085-5019	7-13	47	2	10085-5612	7-22	22	1
10085-5020	7-13	42	1	10085-5620	7-21	122	1
10085-5021	7-13	118	1	10085-5640	7-21	3	1
10085-5022	7-13	120	1	10085-5649	7-22	43	1
10085-5023	7-13	119	1	10085-6000	7-8	0	1
10085-5106	7-5	10	1	10085-6100	7-8	1	1
10085-5113	7-21	144	1	10085-6109	7-32	115	1
10085-5126	7-21	1	1	10085-6120	7-33	3	1
10085-5127	7-20	1	1	10085-6140	7-33	4	1
10085-5128	7-20	2	1	10085-6160	7-33	5	1

Part Number	Fig No.	Index No.	Qty per End Item	Part Number	Fig No.	Index No.	Qty per End Item
10085-6170	7-32	114	1	11-0050-00C	7-11	48	2
10085-6200	7-8	2	1	11-1050-00C	7-20	35	5
10085-6209	7-33	15	1	11-220-B	7-7	17	1
10085-7000	7-5	7	1	113	7-4	3	2
10085-7009	7-26	41	1	1168004P6	7-32	92	1
10085-8010	7-5	4	1	11737761	7-13	129	7
10085-8100	7-14	15	1	12303713	7-25	53	1
10085-8109	7-15	81	1	1240S-4.7-10	7-36	58	1
10085-8110	7-15	25	2	1251-8273	7-23	11	1
10085-8111	7-15	26	2	1251-8274	7-23	13	1
10085-8130	7-15	69	1	151-0625-00	7-28	40	1
10085-8140	7-15	70	1	1546	7-35	40	1
10085-8165	7-14	14	1	1575	7-2	47	1
10085-8170	7-15	72	1	1596/BCBJC	7-11	194	1
10085-8180	7-15	73	1	1730-BLACK	7-6	23	1
10085-8191	7-15	71	2	18092B-B0440-14	7-21	146	4
10085-9000	7-3	14	1	18097B-B0440-14	7-13	137	13
10085-9009	7-25	70	1	18296B-B.129-14	7-15	83	6
10085-9510	7-25	82	1	1854-0583	7-11	78	2
10085-9520	7-25	83	1	199D225X9025BG2	7-23	3	1
10085-9550	7-25	38	1	199D337X06R3EA2	7-15	11	2
10085-9560	7-11	196	1	199D337X96R3FE2	7-15	10	2
10085-9570	7-25	81	1	199D687X9003FE2	7-15	8	1
10087-2011	7-4	12	4	1A12A	7-16	69	1
10087-2012	7-4	13	4	1K-201-J	7-15	68	2
10087-3106	7-9	14	4	1N4738A	7-28	96	2
10088	7-16	82	1	1N4743A	7-28	94	2
10088-6000	7-4	21	1	1N4750A	7-36	14	3
10088-6007	7-10	4	1	1N5311	7-34	16	1
10089	7-16	83	1	2-520182-4	7-35	22	7
1010M	7-23	45	1	2-520184-4	7-29	21	18
10175	7-16	84	1	205817-1	7-6	22	2
10245	7-16	72	1	20590-174AS	7-2	55	1
1025-48	7-15	27	2	207376-1	7-4	8	1
103101	7-25	79	5	207377-1	7-29	28	3
10350-A-1032-2	7-3	12	2	22-01-3037	7-17	22	10
105-0851-001	7-17	115	2	22-01-3057	7-4	6	1
105-0852-001	7-11	184	6	22-01-3077	7-29	27	1
105-0853-001	7-17	116	2	22-01-3087	7-4	7	6
105-0854-001	7-17	117	2	22-03-2021	7-21	29	3
105-0856-001	7-11	185	4	22-03-2022	7-21	37	2
105-0857-001	7-11	186	2	22-03-2032	7-21	36	1
105-0858-001	7-11	183	6	22-11-2032	7-13	45	6
105-0860-001	7-17	112	2	22-11-2052	7-11	54	3
105-0862-001	7-17	113	2	22-11-2082	7-18	49	3
105-0864-001	7-17	114	1	22-11-2092	7-34	19	1
105-1102-001	7-15	74	3	22-11-2112	7-34	18	1
105-1104-001	7-29	38	1	22-12-2034	7-23	10	3
105-1106-001	7-15	75	2	22-12-2074	7-25	12	1
105-1107-001	7-15	76	2	22-14-2024	7-22	15	2
105-854	7-17	111	2	22-14-2034	7-22	14	1
106JP5RWD1250	7-17	10	1	22-SLOTB-BRASS	7-1	24	1
106RAR050APX	7-15	5	1	225398-8	7-7	14	1

Part Number	Fig No.	Index No.	Qty per End Item	Part Number	Fig No.	Index No.	Qty per End Item
2260R	7-25	71	1	372-2333-020	7-32	35	1
2261-N116	7-23	51	2	374753-1	7-35	24	1
241-5-2151	7-2	27	1	389CX-7	7-2	20	1
2425003X5U152Z	7-35	6	2	39TB5	7-34	63	1
25VBSL100	7-15	20	1	3N187	7-18	74	1
260-4TH5B	7-13	124	3	403897-1	7-25	64	3
260-6SH5E	7-14	21	2	41-3-S14-LN2-50	7-2	13	1
2717-24850-N126	7-25	80	6	429E3F99KGZ	7-24	2	1
2743002122	7-18	59	1	43-03-4	7-28	102	5
2813-03-16	7-23	50	7	4306R-102-472	7-25	34	2
2N3806	7-15	79	1	4308R-101-102	7-23	30	1
2N4208	7-21	40	2	4308R-101-103	7-25	22	5
2N4236	7-11	76	4	4308R-101-472	7-23	27	1
2N4392	7-18	77	1	4310R-101-103	7-25	27	6
2N4393	7-21	48	2	4310R-101-471	7-26	22	1
2N5160	7-13	77	1	4318	7-2	51	1
2N5566	7-17	23	3	4520000	7-16	62	1
2N5859	7-34	25	1	4525	7-6	18	1
2N5884	7-35	13	1	476042	7-2	61	1
2N6316	7-36	23	1	4858-1-0516	7-2	59	1
3-520117-2	7-29	25	5	50-1510-0671S	7-7	11	1
302207-B8	7-36	68	1	500-4027-E	7-18	48	1
3101-1261	7-6	2	1	500-5027-E	7-11	55	2
3120GH663U050AP	7-2	10	1	503-3431	7-11	52	5
3299W-1-101	7-11	119	1	5082-3168	7-11	44	2
3299W-1-103	7-16	110	1	5082-4655	7-17	16	2
3299W-1-202	7-21	53	3	51-328-3188-2291	7-7	5	4
3299W-1-502	7-32	54	2	51-328-3188-22G	7-33	21	2
3299W-1-503	7-21	54	3	51-328-3850-910	7-22	21	1
3329H-1-201	7-36	65	1	51-328-3850-916	7-7	2	9
3386B-1-101	7-15	33	2	51-328-3875-220	7-7	12	1
3386B-1-102	7-11	138	2	51-407-116	7-21	28	1
3386B-1-103	7-11	171	1	51718	7-28	89	1
3386B-1-201	7-15	34	3	52-051-0000	7-11	47	5
3386B-1-500	7-11	123	1	524-AG11D	7-21	138	1
3386B-1-501	7-16	98	3	528-AG11D	7-25	68	3
3386B-1-504	7-11	103	2	53892-4	7-14	23	15
3386F-1-102	7-11	96	4	540-AG11D	7-25	67	1
3386F-1-103	7-17	78	1	54483-2	7-14	24	7
3386F-1-104	7-11	90	3	57-342-5	7-21	33	2
3386F-1-202	7-18	135	2	573S1ROOK	7-15	51	2
3386F-1-203	7-17	70	1	588D205-12	7-9	7	2
3386F-1-204	7-11	111	1	609-1007	7-23	12	3
3386F-1-500	7-21	52	1	609-1027	7-11	53	7
3386F-1-502	7-13	89	7	609-1427	7-20	33	4
3386F-1-503	7-18	113	1	609-1627	7-11	51	1
3484-1000	7-5	12	2	609-2027	7-11	50	3
3495-1002	7-26	8	1	609-2607	7-26	7	1
351-8434-010	7-11	188	10	609-3407	7-32	36	1
352-1042-010	7-11	74	18	609-3427	7-16	64	3
353-3733-010	7-11	43	15	61059-1	7-29	26	3

Part Number	Fig No.	Index No.	Qty per End Item	Part Number	Fig No.	Index No.	Qty per End Item
61060-1	7-28	111	3	70HF20	7-2	15	2
61134-1	7-28	104	6	70HFR20	7-2	14	2
61306	7-31	2	1	7101SDV70QE	7-23	31	1
616532-901	7-20	28	24	7107-38	7-11	61	1
622D123M020AM2A	7-35	5	2	710P224X9200MQ	7-36	11	1
622D392M055AM2A	7-35	3	2	72PM2K	7-28	46	1
6232-SS-0632	7-27	7	2	72XWR5K	7-11	139	1
62409-1	7-29	5	3	735P305X9100SL	7-35	4	1
6241-SS-0632-17	7-14	5	2	7401T1ZGE	7-1	23	1
63M501	7-18	100	1	7403-09FR-21	7-2	3	1
65474-001	7-16	1	6	7403-09FR-51	7-14	19	2
65499-101	7-13	122	8	7704701EB	7-12	39	1
65499-102	7-25	77	2	7717-15-DAP	7-14	20	2
65499-103	7-16	66	1	7717-24ODAP	7-15	82	1
65507-107	7-33	6	1	7717-89-DAP	7-13	130	4
65516-110	7-24	5	2	7721-7PPS	7-14	26	5
66098-8	7-29	32	1	7901101CB	7-17	121	1
66100-3	7-29	31	1	7901401EB	7-23	36	1
66101-3	7-29	30	11	7FR2052B	7-30	2	6
6611-0135	7-11	208	79	801591-31	7-28	6	2
6628-1050	7-14	13	1	804991-1	7-23	33	1
66332-7	7-1	26	11	80D222P050KA5	7-29	1	1
672D108H015ET5C	7-28	17	1	82-8666	7-4	5	1
672D128H025FV5J	7-18	35	1	82617	7-2	25	1
672D337H040ET5	7-28	5	7	827S	7-9	15	4
672D337H040ET50	7-28	16	2	841-00	7-1	1	11
672D337H040ET5J	7-34	8	1	850-0038	7-20	103	2
672D476H040CD5C	7-28	22	2	87334-3	7-23	9	2
672D477H025DS5J	7-18	36	2	8962	7-13	56	1
672D477H050FV5J	7-34	2	1	8966	7-13	58	2
672D686H025CD5C	7-34	7	3	905-23	7-6	12	1
68XR2K	7-30	6	2	9200	7-18	62	1
6911-3102	7-16	130	1	9208	7-12	12	1
700-209-NP	7-11	49	19	949	7-29	6	3
700425	7-11	69	2	9725-SS-0440-7	7-4	19	9

## Section IV. REFERENCE DESIGNATOR INDEX

Reference Designation	Fig No.	Index No.	Reference Designation	Fig No.	Index No.	Reference Designation	Fig No.	Index No.
1A1A1	7-1	19	1A1A1C40	7-11	7	1A1A1C95	7-11	15
1A1A1AR1	7-11	2	1A1A1C42	7-11	7	1A1A1C96	7-11	22
1A1A1AR2	7-11	3	1A1A1C43	7-11	19	1A1A1C97	7-11	22
1A1A1AR3	7-11	3	1A1A1C44	7-11	5	1A1A1C98	7-11	34
1A1A1AR4	7-11	3	1A1A1C45	7-11	15	1A1A1C99	7-11	35
1A1A1AR5	7-11	2	1A1A1C46	7-11	7	1A1A1C100	7-11	15
1A1A1AR6	7-11	3	1A1A1C47	7-11	20	1A1A1C101	7-11	7
1A1A1AR7	7-11	3	1A1A1C48	7-11	21	1A1A1C102	7-11	31
1A1A1AR8	7-11	3	1A1A1C49	7-11	7	1A1A1C103	7-11	22
1A1A1AR9	7-11	3	1A1A1C50	7-11	22	1A1A1C104	7-11	15
1A1A1AR10	7-11	3	1A1A1C51	7-11	23	1A1A1C105	7-11	22
1A1A1AR11	7-11	3	1A1A1C52	7-11	7	1A1A1C106	7-11	22
1A1A1AR12	7-11	3	1A1A1C53	7-11	5	1A1A1C107	7-11	22
1A1A1AR13	7-11	3	1A1A1C54	7-11	15	1A1A1C108	7-11	15
1A1A1C1	7-11	4	1A1A1C55	7-11	7	1A1A1C109	7-11	36
1A1A1C3	7-11	5	1A1A1C56	7-11	7	1A1A1C110	7-11	22
1A1A1C4	7-11	6	1A1A1C57	7-11	5	1A1A1C111	7-11	22
1A1A1C5	7-11	7	1A1A1C58	7-11	15	1A1A1C112	7-11	14
1A1A1C6	7-11	8	1A1A1C59	7-11	15	1A1A1C113	7-11	14
1A1A1C7	7-11	9	1A1A1C60	7-11	7	1A1A1C114	7-11	15
1A1A1C8	7-11	10	1A1A1C61	7-11	22	1A1A1C115	7-11	5
1A1A1C9	7-11	11	1A1A1C62	7-11	24	1A1A1C116	7-11	15
1A1A1C10	7-11	5	1A1A1C63	7-11	14	1A1A1C117	7-11	15
1A1A1C11	7-11	7	1A1A1C64	7-11	14	1A1A1C118	7-11	15
1A1A1C12	7-11	12	1A1A1C65	7-11	15	1A1A1C119	7-11	37
1A1A1C13	7-11	13	1A1A1C66	7-11	15	1A1A1C120	7-11	15
1A1A1C14	7-11	14	1A1A1C67	7-11	15	1A1A1C121	7-11	15
1A1A1C15	7-11	7	1A1A1C68	7-11	14	1A1A1C122	7-11	5
1A1A1C16	7-11	15	1A1A1C69	7-11	14	1A1A1C123	7-11	15
1A1A1C17	7-11	12	1A1A1C70	7-11	25	1A1A1C124	7-11	15
1A1A1C18	7-11	13	1A1A1C71	7-11	22	1A1A1C125	7-11	5
1A1A1C19	7-11	14	1A1A1C72	7-11	15	1A1A1C126	7-11	5
1A1A1C20	7-11	7	1A1A1C73	7-11	15	1A1A1C127	7-11	7
1A1A1C21	7-11	15	1A1A1C74	7-11	26	1A1A1C130	7-11	15
1A1A1C22	7-11	12	1A1A1C75	7-11	27	1A1A1C131	7-11	15
1A1A1C23	7-11	13	1A1A1C76	7-11	15	1A1A1C133	7-11	15
1A1A1C24	7-11	14	1A1A1C77	7-11	5	1A1A1C134	7-11	15
1A1A1C25	7-11	16	1A1A1C78	7-11	5	1A1A1C135	7-11	38
1A1A1C26	7-11	17	1A1A1C79	7-11	5	1A1A1C136	7-11	15
1A1A1C27	7-11	7	1A1A1C80	7-11	5	1A1A1C137	7-11	15
1A1A1C28	7-11	12	1A1A1C81	7-11	15	1A1A1C138	7-11	15
1A1A1C29	7-11	13	1A1A1C85	7-11	28	1A1A1C139	7-11	15
1A1A1C30	7-11	14	1A1A1C86	7-11	15	1A1A1C142	7-11	15
1A1A1C31	7-11	17	1A1A1C87	7-11	15	1A1A1C143	7-11	15
1A1A1C32	7-11	17	1A1A1C88	7-11	15	1A1A1C144	7-11	15
1A1A1C33	7-11	5	1A1A1C89	7-11	29	1A1A1C145	7-11	15
1A1A1C34	7-11	7	1A1A1C90	7-11	30	1A1A1C146	7-11	15
1A1A1C36	7-11	14	1A1A1C91	7-11	31	1A1A1C147	7-11	15
1A1A1C37	7-11	15	1A1A1C92	7-11	32	1A1A1C148	7-11	15
1A1A1C38	7-11	18	1A1A1C93	7-11	18	1A1A1C149	7-11	15
1A1A1C39	7-11	15	1A1A1C94	7-11	33	1A1A1C150	7-11	15



Reference Designation	Fig No.	Index No.	Reference Designation	Fig No.	Index No.	Reference Designation	Fig No.	Index No.
1A1A1C151	7-11	15	1A1A1CR14	7-11	41	1A1A1L14	7-11	65
1A1A1C152	7-11	15	1A1A1CR15	7-11	44	1A1A1L15	7-11	62
1A1A1C153	7-11	15	1A1A1CR16	7-11	45	1A1A1L16	7-11	66
1A1A1C154	7-11	15	1A1A1CR17	7-11	45	1A1A1L17	7-11	67
1A1A1C155	7-11	15	1A1A1CR18	7-11	44	1A1A1L18	7-11	66
1A1A1C156	7-11	15	1A1A1CR19	7-11	44	1A1A1M1	7-11	68
1A1A1C157	7-11	15	1A1A1CR20	7-11	44	1A1A1P1	7-11	69
1A1A1C158	7-11	15	1A1A1CR23	7-11	41	1A1A1P2	7-11	69
1A1A1C159	7-11	15	1A1A1CR24	7-11	41	1A1A1Q1	7-11	70
1A1A1C160	7-11	15	1A1A1CR25	7-11	41	1A1A1Q2	7-11	70
1A1A1C162	7-11	15	1A1A1CR26	7-11	41	1A1A1Q3	7-11	71
1A1A1C163	7-11	15	1A1A1CR27	7-11	41	1A1A1Q4	7-11	71
1A1A1C164	7-11	15	1A1A1CR28	7-11	41	1A1A1Q5	7-11	71
1A1A1C165	7-11	15	1A1A1CR29	7-11	46	1A1A1Q6	7-11	71
1A1A1C166	7-11	15	1A1A1CR30	7-11	46	1A1A1Q7	7-11	72
1A1A1C167	7-11	15	1A1A1CR31	7-11	45	1A1A1Q8	7-11	71
1A1A1C168	7-11	15	1A1A1CR32	7-11	45	1A1A1Q9	7-11	71
1A1A1C169	7-11	15	1A1A1CR33	7-11	41	1A1A1Q10	7-11	71
1A1A1C170	7-11	15	1A1A1CR34	7-11	41	1A1A1Q11	7-11	71
1A1A1C171	7-11	15	1A1A1CR35	7-11	41	1A1A1Q12	7-11	71
1A1A1C172	7-11	15	1A1A1CR36	7-11	41	1A1A1Q13	7-11	71
1A1A1C173	7-11	15	1A1A1CR37	7-11	41	1A1A1Q14	7-11	71
1A1A1C174	7-11	15	1A1A1CR38	7-11	41	1A1A1Q15	7-11	73
1A1A1C175	7-11	15	1A1A1CR39	7-11	41	1A1A1Q16	7-11	74
1A1A1C177	7-11	15	1A1A1CR40	7-11	41	1A1A1Q17	7-11	73
1A1A1C178	7-11	15	1A1A1CR42	7-11	41	1A1A1Q18	7-11	73
1A1A1C179	7-11	15	1A1A1CR43	7-11	41	1A1A1Q19	7-11	75
1A1A1C180	7-11	15	1A1A1CR44	7-11	41	1A1A1Q20	7-11	71
1A1A1C181	7-11	39	1A1A1CR45	7-11	41	1A1A1Q21	7-11	71
1A1A1C182	7-11	7	1A1A1J1	7-11	47	1A1A1Q22	7-11	71
1A1A1C183	7-11	15	1A1A1J2	7-11	48	1A1A1Q23	7-11	71
1A1A1C184	7-11	22	1A1A1J3	7-11	49	1A1A1Q24	7-11	71
1A1A1C185	7-11	14	1A1A1J4	7-11	48	1A1A1Q25	7-11	71
1A1A1C186	7-11	14	1A1A1J5	7-11	50	1A1A1Q26	7-11	76
1A1A1C187	7-11	14	1A1A1J6	7-11	51	1A1A1Q27	7-11	76
1A1A1C188	7-11	14	1A1A1J7	7-11	52	1A1A1Q28	7-11	77
1A1A1C189	7-11	15	1A1A1J8	7-11	53	1A1A1Q29	7-11	71
1A1A1C190	7-11	7	1A1A1J9	7-11	54	1A1A1Q30	7-11	71
1A1A1C192	7-11	15	1A1A1J10	7-11	55	1A1A1Q31	7-11	71
1A1A1C193	7-11	15	1A1A1JMP1	7-11	56	1A1A1Q32	7-11	78
1A1A1CR3	7-11	40	1A1A1L2	7-11	57	1A1A1R1	7-11	79
1A1A1CR4	7-11	41	1A1A1L3	7-11	58	1A1A1R2	7-11	80
1A1A1CR5	7-11	41	1A1A1L4	7-11	59	1A1A1R3	7-11	81
1A1A1CR6	7-11	41	1A1A1L5	7-11	60	1A1A1R4	7-11	82
1A1A1CR7	7-11	41	1A1A1L6	7-11	59	1A1A1R5	7-11	79
1A1A1CR8	7-11	40	1A1A1L7	7-11	61	1A1A1R10	7-11	83
1A1A1CR9	7-11	41	1A1A1L9	7-11	59	1A1A1R12	7-11	84
1A1A1CR10	7-11	42	1A1A1L10	7-11	62	1A1A1R13	7-11	80
1A1A1CR11	7-11	43	1A1A1L11	7-11	63	1A1A1R14	7-11	79
1A1A1CR12	7-11	44	1A1A1L12	7-11	64	1A1A1R15	7-11	85
1A1A1CR13	7-11	41	1A1A1L13	7-11	64	1A1A1R16	7-11	86

Reference Designation	Fig No.	Index No.	Reference Designation	Fig No.	Index No.	Reference Designation	Fig No.	Index No.
1A1A1R17	7-11	87	1A1A1R70	7-11	103	1A1A1R124	7-11	125
1A1A1R20	7-11	88	1A1A1R71	7-11	104	1A1A1R125	7-11	85
1A1A1R21	7-11	81	1A1A1R72	7-11	79	1A1A1R126	7-11	89
1A1A1R22	7-11	89	1A1A1R73	7-11	89	1A1A1R127	7-11	85
1A1A1R23	7-11	87	1A1A1R74	7-11	105	1A1A1R128	7-11	126
1A1A1R24	7-11	89	1A1A1R75	7-11	89	1A1A1R129	7-11	127
1A1A1R25	7-11	85	1A1A1R76	7-11	89	1A1A1R130	7-11	88
1A1A1R26	7-11	84	1A1A1R77	7-11	89	1A1A1R131	7-11	128
1A1A1R27	7-11	90	1A1A1R79	7-11	106	1A1A1R132	7-11	129
1A1A1R28	7-11	91	1A1A1R80	7-11	107	1A1A1R133	7-11	130
1A1A1R29	7-11	90	1A1A1R81	7-11	108	1A1A1R134	7-11	131
1A1A1R30	7-11	92	1A1A1R82	7-11	92	1A1A1R135	7-11	132
1A1A1R31	7-11	93	1A1A1R83	7-11	85	1A1A1R136	7-11	117
1A1A1R32	7-11	91	1A1A1R84	7-11	92	1A1A1R137	7-11	81
1A1A1R33	7-11	93	1A1A1R85	7-11	92	1A1A1R138	7-11	81
1A1A1R34	7-11	93	1A1A1R86	7-11	85	1A1A1R139	7-11	133
1A1A1R35	7-11	79	1A1A1R87	7-11	98	1A1A1R140	7-11	113
1A1A1R36	7-11	94	1A1A1R88	7-11	93	1A1A1R141	7-11	134
1A1A1R37	7-11	93	1A1A1R89	7-11	109	1A1A1R142	7-11	135
1A1A1R38	7-11	92	1A1A1R90	7-11	110	1A1A1R143	7-11	81
1A1A1R39	7-11	83	1A1A1R91	7-11	111	1A1A1R144	7-11	136
1A1A1R40	7-11	92	1A1A1R92	7-11	94	1A1A1R145	7-11	137
1A1A1R41	7-11	92	1A1A1R93	7-11	84	1A1A1R146	7-11	137
1A1A1R42	7-11	92	1A1A1R94	7-11	84	1A1A1R147	7-11	102
1A1A1R43	7-11	92	1A1A1R95	7-11	85	1A1A1R148	7-11	138
1A1A1R44	7-11	95	1A1A1R96	7-11	112	1A1A1R149	7-11	81
1A1A1R45	7-11	92	1A1A1R97	7-11	112	1A1A1R150	7-11	117
1A1A1R46	7-11	80	1A1A1R98	7-11	85	1A1A1R151	7-11	139
1A1A1R47	7-11	96	1A1A1R99	7-11	85	1A1A1R152	7-11	140
1A1A1R48	7-11	81	1A1A1R100	7-11	113	1A1A1R153	7-11	141
1A1A1R49	7-11	97	1A1A1R101	7-11	93	1A1A1R154	7-11	91
1A1A1R50	7-11	85	1A1A1R102	7-11	81	1A1A1R155	7-11	97
1A1A1R51	7-11	85	1A1A1R103	7-11	112	1A1A1R156	7-11	80
1A1A1R52	7-11	98	1A1A1R104	7-11	112	1A1A1R158	7-11	142
1A1A1R53	7-11	98	1A1A1R105	7-11	114	1A1A1R159	7-11	143
1A1A1R54	7-11	98	1A1A1R106	7-11	115	1A1A1R161	7-11	144
1A1A1R55	7-11	83	1A1A1R107	7-11	116	1A1A1R162	7-11	145
1A1A1R56	7-11	85	1A1A1R108	7-11	117	1A1A1R163	7-11	81
1A1A1R57	7-11	93	1A1A1R109	7-11	118	1A1A1R164	7-11	146
1A1A1R58	7-11	93	1A1A1R110	7-11	119	1A1A1R165	7-11	133
1A1A1R59	7-11	85	1A1A1R111	7-11	86	1A1A1R166	7-11	147
1A1A1R60	7-11	93	1A1A1R112	7-11	81	1A1A1R167	7-11	148
1A1A1R61	7-11	93	1A1A1R113	7-11	118	1A1A1R168	7-11	92
1A1A1R62	7-11	85	1A1A1R114	7-11	120	1A1A1R169	7-11	85
1A1A1R63	7-11	80	1A1A1R115	7-11	121	1A1A1R170	7-11	149
1A1A1R64	7-11	99	1A1A1R116	7-11	117	1A1A1R171	7-11	150
1A1A1R65	7-11	100	1A1A1R117	7-11	122	1A1A1R172	7-11	151
1A1A1R66	7-11	101	1A1A1R118	7-11	93	1A1A1R173	7-11	152
1A1A1R67	7-11	102	1A1A1R119	7-11	123	1A1A1R174	7-11	153
1A1A1R68	7-11	103	1A1A1R120	7-11	85	1A1A1R175	7-11	81
1A1A1R69	7-11	85	1A1A1R121	7-11	81	1A1A1R176	7-11	128

Reference Designation	Fig No.	Index No.	Reference Designation	Fig No.	Index No.	Reference Designation	Fig No.	Index No.
1A1A1R177	7-11	154	1A1A1R234	7-11	152	1A1A1R290	7-11	97
1A1A1R179	7-11	155	1A1A1R236	7-11	130	1A1A1R291	7-11	79
1A1A1R178	7-11	156	1A1A1R237	7-11	169	1A1A1R292	7-11	128
1A1A1R181	7-11	152	1A1A1R238	7-11	79	1A1A1R293	7-11	79
1A1A1R182	7-11	157	1A1A1R239	7-11	152	1A1A1R294	7-11	89
1A1A1R183	7-11	82	1A1A1R241	7-11	130	1A1A1R295	7-11	102
1A1A1R184	7-11	79	1A1A1R242	7-11	124	1A1A1R296	7-11	89
1A1A1R185	7-11	82	1A1A1R243	7-11	93	1A1A1R297	7-11	178
1A1A1R186	7-11	158	1A1A1R244	7-11	93	1A1A1R298	7-11	179
1A1A1R187	7-11	159	1A1A1R245	7-11	93	1A1A1R299	7-11	180
1A1A1R188	7-11	160	1A1A1R246	7-11	93	1A1A1R300	7-11	181
1A1A1R189	7-11	161	1A1A1R247	7-11	85	1A1A1R301	7-11	79
1A1A1R190	7-11	162	1A1A1R248	7-11	83	1A1A1R302	7-11	80
1A1A1R191	7-11	130	1A1A1R249	7-11	89	1A1A1R303	7-11	80
1A1A1R192	7-11	163	1A1A1R250	7-11	79	1A1A1R304	7-11	85
1A1A1R193	7-11	80	1A1A1R251	7-11	89	1A1A1R305	7-11	79
1A1A1R194	7-11	102	1A1A1R252	7-11	170	1A1A1R306	7-11	85
1A1A1R195	7-11	146	1A1A1R253	7-11	89	1A1A1R307	7-11	89
1A1A1R196	7-11	164	1A1A1R254	7-11	171	1A1A1T1	7-11	182
1A1A1R197	7-11	165	1A1A1R255	7-11	172	1A1A1TP1	7-11	183
1A1A1R198	7-11	102	1A1A1R256	7-11	89	1A1A1TP2	7-11	184
1A1A1R199	7-11	125	1A1A1R257	7-11	105	1A1A1TP3	7-11	185
1A1A1R200	7-11	161	1A1A1R258	7-11	89	1A1A1TP4	7-11	186
1A1A1R201	7-11	79	1A1A1R259	7-11	85	1A1A1U1	7-11	187
1A1A1R203	7-11	166	1A1A1R260	7-11	83	1A1A1U2	7-11	188
1A1A1R204	7-11	81	1A1A1R261	7-11	85	1A1A1U3	7-11	189
1A1A1R205	7-11	79	1A1A1R262	7-11	85	1A1A1U4	7-11	189
1A1A1R206	7-11	85	1A1A1R263	7-11	79	1A1A1U5	7-11	190
1A1A1R207	7-11	84	1A1A1R264	7-11	85	1A1A1U6	7-11	191
1A1A1R208	7-11	81	1A1A1R265	7-11	82	1A1A1U7	7-11	191
1A1A1R209	7-11	80	1A1A1R266	7-11	98	1A1A1U8	7-11	192
1A1A1R210	7-11	84	1A1A1R267	7-11	89	1A1A1U9	7-11	189
1A1A1R211	7-11	81	1A1A1R268	7-11	85	1A1A1U10	7-11	193
1A1A1R212	7-11	84	1A1A1R269	7-11	79	1A1A1U11	7-11	189
1A1A1R213	7-11	81	1A1A1R270	7-11	173	1A1A1U12	7-11	194
1A1A1R214	7-11	85	1A1A1R271	7-11	174	1A1A1U13	7-11	189
1A1A1R215	7-11	83	1A1A1R272	7-11	89	1A1A1U14	7-11	195
1A1A1R217	7-11	89	1A1A1R273	7-11	85	1A1A1U15	7-11	196
1A1A1R218	7-11	141	1A1A1R274	7-11	97	1A1A1U16	7-11	197
1A1A1R219	7-11	98	1A1A1R276	7-11	175	1A1A1U17	7-11	189
1A1A1R220	7-11	93	1A1A1R277	7-11	176	1A1A1U18	7-11	189
1A1A1R221	7-11	80	1A1A1R279	7-11	168	1A1A1U19	7-11	198
1A1A1R222	7-11	83	1A1A1R280	7-11	177	1A1A1U20	7-11	199
1A1A1R223	7-11	89	1A1A1R281	7-11	93	1A1A1U21	7-11	200
1A1A1R226	7-11	98	1A1A1R282	7-11	97	1A1A1U22	7-11	200
1A1A1R227	7-11	105	1A1A1R283	7-11	79	1A1A1U23	7-11	200
1A1A1R228	7-11	167	1A1A1R285	7-11	157	1A1A1U24	7-11	200
1A1A1R229	7-11	132	1A1A1R286	7-11	157	1A1A1U25	7-11	201
1A1A1R230	7-11	168	1A1A1R287	7-11	107	1A1A1U26	7-11	202
1A1A1R231	7-11	89	1A1A1R288	7-11	79	1A1A1U27	7-11	203
1A1A1R232	7-11	80	1A1A1R289	7-11	168	1A1A1VR1	7-11	204

Reference Designation	Fig No.	Index No.	Reference Designation	Fig No.	Index No.	Reference Designation	Fig No.	Index No.
1A1A1VR2	7-11	205	1A1A2FL1	7-12	7	1A1A2R39	7-12	18
1A1A1VR3	7-11	205	1A1A2FL2	7-12	8	1A1A2R40	7-12	18
1A1A1VR4	7-11	205	1A1A2FL3	7-12	9	1A1A2R41	7-12	32
1A1A1VR5	7-11	204	1A1A2J1	7-12	10	1A1A2R42	7-12	33
1A1A1Y1	7-11	206	1A1A2J2	7-12	10	1A1A2R43	7-12	34
			1A1A2J3	7-12	11	1A1A2R44	7-12	18
1A1A2	7-5	3	1A1A2J5	7-12	10	1A1A2R45	7-12	35
1A1A2AR1	7-12	1	1A1A2J6	7-12	10	1A1A2R46	7-12	36
1A1A2AR2	7-12	1	1A1A2L2	7-12	12	1A1A2R47	7-12	17
1A1A2C1	7-12	2	1A1A2L3	7-12	13	1A1A2R48	7-12	32
1A1A2C2	7-12	3	1A1A2L4	7-12	13	1A1A2R49	7-12	37
1A1A2C3	7-12	3	1A1A2L5	7-12	13	1A1A2R50	7-12	34
1A1A2C4	7-12	4	1A1A2Q1	7-12	14	1A1A2R51	7-12	32
1A1A2C5	7-12	3	1A1A2Q2	7-12	15	1A1A2R52	7-12	32
1A1A2C7	7-12	2	1A1A2Q3	7-12	15	1A1A2R53	7-12	32
1A1A2C9	7-12	3	1A1A2Q4	7-12	16	1A1A2R54	7-12	36
1A1A2C10	7-12	3	1A1A2Q5	7-12	16	1A1A2R55	7-12	36
1A1A2C11	7-12	3	1A1A2Q6	7-12	15	1A1A2R56	7-12	36
1A1A2C12	7-12	3	1A1A2Q7	7-12	15	1A1A2R57	7-12	19
1A1A2C13	7-12	3	1A1A2Q8	7-12	15	1A1A2R58	7-12	18
1A1A2C14	7-12	3	1A1A2R1	7-12	17	1A1A2R59	7-12	19
1A1A2C27	7-12	2	1A1A2R2	7-12	18	1A1A2R60	7-12	25
1A1A2C28	7-12	2	1A1A2R3	7-12	19	1A1A2S1	7-12	38
1A1A2C29	7-12	2	1A1A2R4	7-12	20	1A1A2U1	7-12	39
1A1A2C30	7-12	2	1A1A2R5	7-12	21			
1A1A2C31	7-12	2	1A1A2R6	7-12	22	1A1A3	7-3	8
1A1A2C32	7-12	2	1A1A2R7	7-12	23	1A1A3AR1	7-13	3
1A1A2C33	7-12	2	1A1A2R8	7-12	19	1A1A3C1	7-13	4
1A1A2C34	7-12	2	1A1A2R9	7-12	24	1A1A3C2	7-13	5
1A1A2C35	7-12	3	1A1A2R10	7-12	25	1A1A3C3	7-13	6
1A1A2C36	7-12	5	1A1A2R18	7-12	18	1A1A3C4	7-13	7
1A1A2C37	7-12	3	1A1A2R19	7-12	26	1A1A3C5	7-13	6
1A1A2C38	7-12	5	1A1A2R20	7-12	27	1A1A3C6	7-13	8
1A1A2C39	7-12	3	1A1A2R21	7-12	25	1A1A3C7	7-13	6
1A1A2C40	7-12	5	1A1A2R22	7-12	28	1A1A3C8	7-13	6
1A1A2C42	7-12	2	1A1A2R23	7-12	18	1A1A3C9	7-13	6
1A1A2CR5	7-12	6	1A1A2R24	7-12	26	1A1A3C11	7-13	6
1A1A2CR6	7-12	6	1A1A2R25	7-12	29	1A1A3C12	7-13	9
1A1A2CR7	7-12	6	1A1A2R26	7-12	25	1A1A3C13	7-13	10
1A1A2CR8	7-12	6	1A1A2R27	7-12	28	1A1A3C14	7-13	11
1A1A2CR9	7-12	6	1A1A2R28	7-12	18	1A1A3C15	7-13	12
1A1A2CR10	7-12	6	1A1A2R29	7-12	26	1A1A3C16	7-13	13
1A1A2CR11	7-12	6	1A1A2R30	7-12	29	1A1A3C17	7-13	14
1A1A2CR12	7-12	6	1A1A2R31	7-12	25	1A1A3C18	7-13	15
1A1A2CR13	7-12	6	1A1A2R32	7-12	28	1A1A3C19	7-13	15
1A1A2CR14	7-12	6	1A1A2R33	7-12	28	1A1A3C20	7-13	16
1A1A2CR15	7-12	6	1A1A2R34	7-12	30	1A1A3C21	7-13	17
1A1A2CR16	7-12	6	1A1A2R35	7-12	31	1A1A3C22	7-13	18
1A1A2CR17	7-12	6	1A1A2R36	7-12	18	1A1A3C23	7-13	19
1A1A2CR18	7-12	6	1A1A2R37	7-12	18	1A1A3C24	7-13	20
1A1A2CR19	7-12	6	1A1A2R38	7-12	18	1A1A3C25	7-13	21

Reference Designation	Fig No.	Index No.	Reference Designation	Fig No.	Index No.	Reference Designation	Fig No.	Index No.
1A1A3C26	7-13	22	1A1A3C78	7-13	22	1A1A3L5	7-13	49
1A1A3C28	7-13	23	1A1A3C79	7-13	34	1A1A3L6	7-13	48
1A1A3C29	7-13	22	1A1A3C80	7-13	22	1A1A3L7	7-13	50
1A1A3C30	7-13	22	1A1A3C81	7-13	35	1A1A3L8	7-13	51
1A1A3C31	7-13	22	1A1A3C82	7-13	6	1A1A3L9	7-13	50
1A1A3C32	7-13	24	1A1A3C83	7-13	24	1A1A3L10	7-13	52
1A1A3C33	7-13	25	1A1A3C84	7-13	22	1A1A3L11	7-13	53
1A1A3C34	7-13	22	1A1A3C85	7-13	36	1A1A3L12	7-13	54
1A1A3C35	7-13	22	1A1A3C86	7-13	22	1A1A3L13	7-13	55
1A1A3C36	7-13	22	1A1A3C87	7-13	36	1A1A3L14	7-13	56
1A1A3C37	7-13	22	1A1A3C88	7-13	6	1A1A3L15	7-13	57
1A1A3C38	7-13	22	1A1A3C89	7-13	6	1A1A3L16	7-13	57
1A1A3C39	7-13	22	1A1A3C90	7-13	6	1A1A3L17	7-13	58
1A1A3C40	7-13	6	1A1A3C92	7-13	22	1A1A3L18	7-13	59
1A1A3C41	7-13	22	1A1A3C93	7-13	22	1A1A3L19	7-13	60
1A1A3C42	7-13	22	1A1A3C94	7-13	22	1A1A3L20	7-13	60
1A1A3C43	7-13	22	1A1A3C95	7-13	22	1A1A3L21	7-13	61
1A1A3C44	7-13	22	1A1A3C96	7-13	22	1A1A3L22	7-13	62
1A1A3C45	7-13	5	1A1A3CR1	7-13	37	1A1A3L23	7-13	62
1A1A3C46	7-13	6	1A1A3CR2	7-13	37	1A1A3L24	7-13	63
1A1A3C47	7-13	26	1A1A3CR3	7-13	37	1A1A3L25	7-13	60
1A1A3C48	7-13	6	1A1A3CR4	7-13	37	1A1A3L26	7-13	64
1A1A3C49	7-13	6	1A1A3CR5	7-13	38	1A1A3L27	7-13	65
1A1A3C50	7-13	27	1A1A3CR6	7-13	38	1A1A3L28	7-13	60
1A1A3C51	7-13	22	1A1A3CR7	7-13	39	1A1A3L29	7-13	66
1A1A3C52	7-13	28	1A1A3CR8	7-13	39	1A1A3L30	7-13	55
1A1A3C53	7-13	29	1A1A3CR10	7-13	39	1A1A3L31	7-13	66
1A1A3C54	7-13	30	1A1A3CR11	7-13	39	1A1A3L32	7-13	67
1A1A3C55	7-13	6	1A1A3CR12	7-13	40	1A1A3L33	7-13	68
1A1A3C56	7-13	6	1A1A3CR13	7-13	41	1A1A3L34	7-13	61
1A1A3C57	7-13	6	1A1A3CR14	7-13	41	1A1A3L35	7-13	68
1A1A3C58	7-13	6	1A1A3CR15	7-13	40	1A1A3L36	7-13	61
1A1A3C59	7-13	6	1A1A3CR16	7-13	40	1A1A3L37	7-13	69
1A1A3C60	7-13	27	1A1A3CR17	7-13	38	1A1A3L38	7-13	70
1A1A3C61	7-13	6	1A1A3CR18	7-13	38	1A1A3L39	7-13	61
1A1A3C62	7-13	31	1A1A3CR19	7-13	38	1A1A3L40	7-13	61
1A1A3C63	7-13	22	1A1A3CR20	7-13	38	1A1A3L41	7-13	61
1A1A3C64	7-13	6	1A1A3CR21	7-13	38	1A1A3L42	7-13	61
1A1A3C65	7-13	32	1A1A3FL1	7-13	42	1A1A3L43	7-13	65
1A1A3C66	7-13	6	1A1A3J1	7-13	43	1A1A3Q1	7-13	71
1A1A3C67	7-13	22	1A1A3J2	7-13	43	1A1A3Q2	7-13	72
1A1A3C68	7-13	5	1A1A3J3	7-13	43	1A1A3Q3	7-13	73
1A1A3C69	7-13	15	1A1A3J4	7-13	43	1A1A3Q4	7-13	74
1A1A3C70	7-13	5	1A1A3J5	7-13	43	1A1A3Q6	7-13	75
1A1A3C71	7-13	22	1A1A3J6	7-13	44	1A1A3Q7	7-13	75
1A1A3C72	7-13	22	1A1A3J7	7-13	45	1A1A3Q8	7-13	73
1A1A3C73	7-13	6	1A1A3JMP1	7-13	46	1A1A3Q9	7-13	76
1A1A3C74	7-13	22	1A1A3L1	7-13	47	1A1A3Q10	7-13	76
1A1A3C75	7-13	22	1A1A3L2	7-13	47	1A1A3Q11	7-13	76
1A1A3C76	7-13	22	1A1A3L3	7-13	48	1A1A3Q12	7-13	73
1A1A3C77	7-13	33	1A1A3L4	7-13	48	1A1A3Q13	7-13	71

Reference Designation	Fig No.	Index No.	Reference Designation	Fig No.	Index No.	Reference Designation	Fig No.	Index No.
1A1A3Q14	7-13	77	1A1A3R47	7-13	84	1A1A4A1C6	7-15	3
1A1A3Q15	7-13	76	1A1A3R48	7-13	90	1A1A4A1C7	7-15	5
1A1A3Q17	7-13	78	1A1A3R49	7-13	104	1A1A4A1C8	7-15	6
1A1A3Q18	7-13	78	1A1A3R50	7-13	104	1A1A4A1C9	7-15	3
1A1A3Q19	7-13	78	1A1A3R51	7-13	94	1A1A4A1C10	7-15	3
1A1A3Q16	7-13	76	1A1A3R52	7-13	106	1A1A4A1C11	7-15	1
1A1A3Q20	7-13	78	1A1A3R53	7-13	79	1A1A4A1C12	7-15	2
1A1A3R1	7-13	79	1A1A3R54	7-13	107	1A1A4A1C13	7-15	7
1A1A3R2	7-13	80	1A1A3R55	7-13	108	1A1A4A1C14	7-15	8
1A1A3R2	7-13	81	1A1A3R56	7-13	85	1A1A4A1C15	7-15	3
1A1A3R3	7-13	82	1A1A3R57	7-13	109	1A1A4A1C16	7-15	9
1A1A3R4	7-13	83	1A1A3R58	7-13	110	1A1A4A1C17	7-15	3
1A1A3R5	7-13	82	1A1A3R59	7-13	111	1A1A4A1C18	7-15	3
1A1A3R6	7-13	84	1A1A3R60	7-13	111	1A1A4A1C19	7-15	3
1A1A3R7	7-13	80	1A1A3R61	7-13	92	1A1A4A1C20	7-15	3
1A1A3R8	7-13	85	1A1A3R62	7-13	105	1A1A4A1C21	7-15	3
1A1A3R9	7-13	86	1A1A3R63	7-13	105	1A1A4A1C22	7-15	7
1A1A3R10	7-13	87	1A1A3R64	7-13	92	1A1A4A1C23	7-15	10
1A1A3R13	7-13	79	1A1A3R65	7-13	105	1A1A4A1C24	7-15	11
1A1A3R14	7-13	88	1A1A3R66	7-13	112	1A1A4A1C25	7-15	3
1A1A3R16	7-13	46	1A1A3R67	7-13	113	1A1A4A1C26	7-15	12
1A1A3R17	7-13	89	1A1A3R68	7-13	114	1A1A4A1C27	7-15	13
1A1A3R18	7-13	82	1A1A3R69	7-13	115	1A1A4A1C30	7-15	14
1A1A3R19	7-13	90	1A1A3R70	7-13	116	1A1A4A1C31	7-15	3
1A1A3R20	7-13	91	1A1A3R71	7-13	107	1A1A4A1C32	7-15	3
1A1A3R21	7-13	82	1A1A3R72	7-13	80	1A1A4A1C33	7-15	3
1A1A3R22	7-13	92	1A1A3T1	7-13	32	1A1A4A1C34	7-15	15
1A1A3R23	7-13	91	1A1A3T2	7-13	117	1A1A4A1C36	7-15	16
1A1A3R24	7-13	93	1A1A3T3	7-13	118	1A1A4A1C37	7-15	17
1A1A3R25	7-13	94	1A1A3T4	7-13	119	1A1A4A1C38	7-15	3
1A1A3R26	7-13	90	1A1A3T5	7-13	120	1A1A4A1C39	7-15	3
1A1A3R27	7-13	95	1A1A3T6	7-13	121	1A1A4A1C40	7-15	3
1A1A3R28	7-13	87	1A1A3TP1	7-13	122	1A1A4A1C41	7-15	3
1A1A3R29	7-13	96				1A1A4A1C42	7-15	3
1A1A3R30	7-13	97	1A1A4	7-5	4	1A1A4A1C43	7-15	3
1A1A3R31	7-13	97	1A1A4CR12	7-14	7	1A1A4A1C44	7-15	3
1A1A3R32	7-13	96	1A1A4Q1	7-14	8	1A1A4A1C45	7-15	3
1A1A3R33	7-13	83	1A1A4Q2	7-14	9	1A1A4A1C46	7-15	3
1A1A3R34	7-13	98	1A1A4Q4	7-14	10	1A1A4A1C47	7-15	3
1A1A3R35	7-13	99	1A1A4Q7	7-14	11	1A1A4A1C48	7-15	18
1A1A3R36	7-13	100	1A1A4Q8	7-14	12	1A1A4A1C49	7-15	3
1A1A3R37	7-13	93	1A1A4Q9	7-14	11	1A1A4A1C50	7-15	19
1A1A3R38	7-13	101	1A1A4Q10	7-14	12	1A1A4A1C51	7-15	3
1A1A3R39	7-13	102	1A1A4RT1	7-14	13	1A1A4A1C59	7-15	3
1A1A3R40	7-13	103	1A1A4T7	7-14	14	1A1A4A1C52	7-15	3
1A1A3R41	7-13	104	1A1A4A1	7-14	15	1A1A4A1C53	7-15	3
1A1A3R42	7-13	97	1A1A4A1C1	7-15	1	1A1A4A1C54	7-15	3
1A1A3R43	7-13	97	1A1A4A1C2	7-15	2	1A1A4A1C55	7-15	3
1A1A3R44	7-13	105	1A1A4A1C3	7-15	3	1A1A4A1C56	7-15	3
1A1A3R45	7-13	96	1A1A4A1C4	7-15	3	1A1A4A1C57	7-15	3
1A1A3R46	7-13	79	1A1A4A1C5	7-15	4	1A1A4A1C58	7-15	3

Reference Designation	Fig No.	Index No.	Reference Designation	Fig No.	Index No.	Reference Designation	Fig No.	Index No.
1A1A4A1C60	7-15	3	1A1A4A1R21	7-15	44	1A1A4A1T2	7-15	70
1A1A4A1C61	7-15	3	1A1A4A1R22	7-15	44	1A1A4A1T3	7-15	71
1A1A4A1C62	7-15	7	1A1A4A1R23	7-15	44	1A1A4A1T4	7-15	72
1A1A4A1C63	7-15	3	1A1A4A1R24	7-15	45	1A1A4A1T5	7-15	71
1A1A4A1C64	7-15	20	1A1A4A1R25	7-15	46	1A1A4A1T6	7-15	73
1A1A4A1C65	7-15	3	1A1A4A1R26	7-15	47	1A1A4A1TP2	7-15	74
1A1A4A1C66	7-15	3	1A1A4A1R27	7-15	48	1A1A4A1TP3	7-15	75
1A1A4A1C68	7-15	3	1A1A4A1R28	7-15	49	1A1A4A1TP4	7-15	76
1A1A4A1CR1	7-15	21	1A1A4A1R29	7-15	50	1A1A4A1U1	7-15	77
1A1A4A1CR2	7-15	21	1A1A4A1R30	7-15	51	1A1A4A1U2	7-15	78
1A1A4A1CR3	7-15	22	1A1A4A1R31	7-15	47	1A1A4A1U3	7-15	79
1A1A4A1CR4	7-15	21	1A1A4A1R32	7-15	48	1A1A4A1VR1	7-15	80
1A1A4A1CR5	7-15	21	1A1A4A1R33	7-15	49			
1A1A4A1CR6	7-15	21	1A1A4A1R34	7-15	50	1A1A5	7-5	5
1A1A4A1CR7	7-15	21	1A1A4A1R35	7-15	52	1A1A5AR1	7-16	3
1A1A4A1CR8	7-15	21	1A1A4A1R36	7-15	53	1A1A5AR2	7-16	4
1A1A4A1CR9	7-15	21	1A1A4A1R37	7-15	45	1A1A5C1	7-16	5
1A1A4A1CR13	7-15	21	1A1A4A1R38	7-15	54	1A1A5C3	7-16	6
1A1A4A1J6	7-15	23	1A1A4A1R39	7-15	55	1A1A5C4	7-16	7
1A1A4A1J7	7-15	23	1A1A4A1R40	7-15	56	1A1A5C5	7-16	7
1A1A4A1JMP1	7-15	24	1A1A4A1R41	7-15	57	1A1A5C6	7-16	7
1A1A4A1L1	7-15	25	1A1A4A1R42	7-15	49	1A1A5C7	7-16	8
1A1A4A1L2	7-15	26	1A1A4A1R43	7-15	58	1A1A5C9	7-16	8
1A1A4A1L3	7-15	25	1A1A4A1R44	7-15	58	1A1A5C11	7-16	8
1A1A4A1L4	7-15	26	1A1A4A1R45	7-15	56	1A1A5C13	7-16	8
1A1A4A1L5	7-15	27	1A1A4A1R46	7-15	59	1A1A5C15	7-16	9
1A1A4A1L6	7-15	27	1A1A4A1R47	7-15	49	1A1A5C16	7-16	10
1A1A4A1P1	7-15	28	1A1A4A1R48	7-15	60	1A1A5C17	7-16	11
1A1A4A1Q6	7-15	29	1A1A4A1R49	7-15	53	1A1A5C18	7-16	11
1A1A4A1Q11	7-15	30	1A1A4A1R50	7-15	61	1A1A5C19	7-16	11
1A1A4A1Q12	7-15	31	1A1A4A1R51	7-15	62	1A1A5C20	7-16	11
1A1A4A1R1	7-15	32	1A1A4A1R52	7-15	63	1A1A5C21	7-16	11
1A1A4A1R2	7-15	33	1A1A4A1R53	7-15	63	1A1A5C22	7-16	11
1A1A4A1R3	7-15	34	1A1A4A1R54	7-15	61	1A1A5C23	7-16	12
1A1A4A1R4	7-15	34	1A1A4A1R55	7-15	64	1A1A5C24	7-16	12
1A1A4A1R5	7-15	34	1A1A4A1R56	7-15	65	1A1A5C25	7-16	13
1A1A4A1R6	7-15	35	1A1A4A1R57	7-15	59	1A1A5C26	7-16	14
1A1A4A1R7	7-15	36	1A1A4A1R58	7-15	59	1A1A5C27	7-16	14
1A1A4A1R8	7-15	37	1A1A4A1R59	7-15	66	1A1A5C28	7-16	14
1A1A4A1R9	7-15	38	1A1A4A1R60	7-15	66	1A1A5C29	7-16	14
1A1A4A1R10	7-15	38	1A1A4A1R61	7-15	67	1A1A5C30	7-16	15
1A1A4A1R11	7-15	39	1A1A4A1R62	7-15	67	1A1A5C31	7-16	15
1A1A4A1R12	7-15	40	1A1A4A1R63	7-15	67	1A1A5C32	7-16	15
1A1A4A1R13	7-15	40	1A1A4A1R64	7-15	67	1A1A5C33	7-16	15
1A1A4A1R14	7-15	41	1A1A4A1R65	7-15	51	1A1A5C34	7-16	16
1A1A4A1R15	7-15	41	1A1A4A1R66	7-15	46	1A1A5C35	7-16	14
1A1A4A1R16	7-15	42	1A1A4A1R67	7-15	42	1A1A5C36	7-16	17
1A1A4A1R17	7-15	42	1A1A4A1R68	7-15	49	1A1A5C37	7-16	8
1A1A4A1R18	7-15	42	1A1A4A1RT2	7-15	68	1A1A5C38	7-16	8
1A1A4A1R19	7-15	42	1A1A4A1RT3	7-15	68	1A1A5C39	7-16	18
1A1A4A1R20	7-15	43	1A1A4A1T1	7-15	69	1A1A5C40	7-16	19

Reference Designation	Fig No.	Index No.	Reference Designation	Fig No.	Index No.	Reference Designation	Fig No.	Index No.
1A1A5C41	7-16	20	1A1A5C92	7-16	35	1A1A5C143	7-16	39
1A1A5C42	7-16	20	1A1A5C93	7-16	36	1A1A5C144	7-16	39
1A1A5C43	7-16	20	1A1A5C94	7-16	37	1A1A5C145	7-16	39
1A1A5C44	7-16	20	1A1A5C95	7-16	37	1A1A5C146	7-16	47
1A1A5C45	7-16	20	1A1A5C96	7-16	28	1A1A5C147	7-16	47
1A1A5C46	7-16	21	1A1A5C97	7-16	28	1A1A5C148	7-16	47
1A1A5C47	7-16	22	1A1A5C98	7-16	28	1A1A5C149	7-16	47
1A1A5C48	7-16	23	1A1A5C99	7-16	18	1A1A5C150	7-16	47
1A1A5C49	7-16	24	1A1A5C100	7-16	18	1A1A5C151	7-16	39
1A1A5C50	7-16	25	1A1A5C101	7-16	18	1A1A5C152	7-16	48
1A1A5C51	7-16	25	1A1A5C102	7-16	18	1A1A5C153	7-16	48
1A1A5C52	7-16	25	1A1A5C103	7-16	18	1A1A5C154	7-16	40
1A1A5C53	7-16	25	1A1A5C104	7-16	28	1A1A5C155	7-16	8
1A1A5C54	7-16	11	1A1A5C105	7-16	28	1A1A5C156	7-16	39
1A1A5C55	7-16	24	1A1A5C106	7-16	28	1A1A5C157	7-16	39
1A1A5C56	7-16	24	1A1A5C107	7-16	38	1A1A5C158	7-16	39
1A1A5C57	7-16	24	1A1A5C108	7-16	38	1A1A5C159	7-16	49
1A1A5C58	7-16	24	1A1A5C109	7-16	27	1A1A5C160	7-16	50
1A1A5C59	7-16	26	1A1A5C110	7-16	28	1A1A5C161	7-16	8
1A1A5C60	7-16	23	1A1A5C111	7-16	8	1A1A5C162	7-16	8
1A1A5C61	7-16	8	1A1A5C112	7-16	8	1A1A5C169	7-16	8
1A1A5C62	7-16	8	1A1A5C113	7-16	39	1A1A5C170	7-16	8
1A1A5C63	7-16	27	1A1A5C114	7-16	40	1A1A5C171	7-16	8
1A1A5C64	7-16	28	1A1A5C115	7-16	41	1A1A5C172	7-16	8
1A1A5C65	7-16	28	1A1A5C116	7-16	41	1A1A5C174	7-16	8
1A1A5C66	7-16	28	1A1A5C117	7-16	41	1A1A5C175	7-16	8
1A1A5C67	7-16	28	1A1A5C118	7-16	41	1A1A5C176	7-16	8
1A1A5C68	7-16	28	1A1A5C119	7-16	41	1A1A5C177	7-16	51
1A1A5C69	7-16	28	1A1A5C120	7-16	41	1A1A5C178	7-16	51
1A1A5C70	7-16	28	1A1A5C121	7-16	35	1A1A5C179	7-16	20
1A1A5C71	7-16	18	1A1A5C122	7-16	35	1A1A5C180	7-16	8
1A1A5C72	7-16	29	1A1A5C123	7-16	42	1A1A5C181	7-16	52
1A1A5C73	7-16	30	1A1A5C124	7-16	37	1A1A5C182	7-16	8
1A1A5C74	7-16	30	1A1A5C125	7-16	37	1A1A5C184	7-16	8
1A1A5C75	7-16	31	1A1A5C126	7-16	37	1A1A5C186	7-16	8
1A1A5C76	7-16	31	1A1A5C127	7-16	37	1A1A5C187	7-16	53
1A1A5C77	7-16	31	1A1A5C128	7-16	35	1A1A5C188	7-16	25
1A1A5C78	7-16	31	1A1A5C129	7-16	43	1A1A5C189	7-16	42
1A1A5C79	7-16	32	1A1A5C130	7-16	44	1A1A5C190	7-16	54
1A1A5C80	7-16	32	1A1A5C131	7-16	44	1A1A5C191	7-16	54
1A1A5C81	7-16	32	1A1A5C132	7-16	44	1A1A5C192	7-16	55
1A1A5C82	7-16	32	1A1A5C133	7-16	44	1A1A5C194	7-16	8
1A1A5C83	7-16	32	1A1A5C134	7-16	8	1A1A5C196	7-16	56
1A1A5C84	7-16	30	1A1A5C135	7-16	38	1A1A5C198	7-16	56
1A1A5C85	7-16	30	1A1A5C136	7-16	8	1A1A5C202	7-16	8
1A1A5C86	7-16	8	1A1A5C137	7-16	8	1A1A5C203	7-16	8
1A1A5C87	7-16	8	1A1A5C138	7-16	39	1A1A5C204	7-16	57
1A1A5C88	7-16	33	1A1A5C139	7-16	45	1A1A5C206	7-16	58
1A1A5C89	7-16	34	1A1A5C140	7-16	46	1A1A5C207	7-16	59
1A1A5C90	7-16	35	1A1A5C141	7-16	47	1A1A5C208	7-16	8
1A1A5C91	7-16	35	1A1A5C142	7-16	47	1A1A5C209	7-16	42



Reference Designation	Fig No.	Index No.	Reference Designation	Fig No.	Index No.	Reference Designation	Fig No.	Index No.
1A1A5C210	7-16	8	1A1A5K14	7-16	68	1A1A5R9	7-16	103
1A1A5C211	7-16	8	1A1A5K15	7-16	69	1A1A5R10	7-16	104
1A1A5C212	7-16	42	1A1A5L1	7-16	70	1A1A5R11	7-16	105
1A1A5C213	7-16	37	1A1A5L2	7-16	71	1A1A5R12	7-16	106
1A1A5C214	7-16	8	1A1A5L3	7-16	72	1A1A5R13	7-16	107
1A1A5C216	7-16	8	1A1A5L4	7-16	73	1A1A5R14	7-16	106
1A1A5C217	7-16	8	1A1A5L5	7-16	74	1A1A5R15	7-16	108
1A1A5C219	7-16	8	1A1A5L6	7-16	75	1A1A5R16	7-16	109
1A1A5C220	7-16	8	1A1A5L7	7-16	76	1A1A5R17	7-16	110
1A1A5C221	7-16	8	1A1A5L8	7-16	77	1A1A5R18	7-16	111
1A1A5C228	7-16	8	1A1A5L9	7-16	78	1A1A5R19	7-16	112
1A1A5C229	7-16	8	1A1A5L10	7-16	79	1A1A5R20	7-16	113
1A1A5C230	7-16	8	1A1A5L11	7-16	80	1A1A5R21	7-16	114
1A1A5C231	7-16	42	1A1A5L12	7-16	81	1A1A5R22	7-16	105
1A1A5CR1	7-16	60	1A1A5L13	7-16	82	1A1A5R23	7-16	105
1A1A5CR2	7-16	60	1A1A5L14	7-16	83	1A1A5R24	7-16	105
1A1A5CR3	7-16	61	1A1A5L15	7-16	84	1A1A5R25	7-16	115
1A1A5CR4	7-16	60	1A1A5L16	7-16	85	1A1A5R26	7-16	116
1A1A5CR5	7-16	61	1A1A5L17	7-16	86	1A1A5R27	7-16	117
1A1A5CR6	7-16	61	1A1A5L18	7-16	87	1A1A5R28	7-16	101
1A1A5CR7	7-16	60	1A1A5L20	7-16	88	1A1A5R29	7-16	105
1A1A5CR8	7-16	60	1A1A5L21	7-16	88	1A1A5R31	7-16	118
1A1A5CR9	7-16	60	1A1A5L24	7-16	89	1A1A5R32	7-16	119
1A1A5CR10	7-16	60	1A1A5L25	7-16	89	1A1A5R33	7-16	120
1A1A5CR11	7-16	60	1A1A5L27	7-16	89	1A1A5R34	7-16	104
1A1A5CR12	7-16	60	1A1A5L31	7-16	90	1A1A5R35	7-16	121
1A1A5CR13	7-16	60	1A1A5L32	7-16	91	1A1A5R36	7-16	100
1A1A5CR14	7-16	60	1A1A5L33	7-16	91	1A1A5R37	7-16	121
1A1A5E1	7-16	62	1A1A5L34	7-16	91	1A1A5R38	7-16	104
1A1A5J1	7-16	63	1A1A5L35	7-16	91	1A1A5R39	7-16	104
1A1A5J2	7-16	63	1A1A5L36	7-16	91	1A1A5R40	7-16	122
1A1A5J3	7-16	63	1A1A5L37	7-16	91	1A1A5R42	7-16	123
1A1A5J4	7-16	63	1A1A5L42	7-16	89	1A1A5R43	7-16	123
1A1A5J5	7-16	64	1A1A5L43	7-16	91	1A1A5R44	7-16	102
1A1A5J6	7-16	65	1A1A5L44	7-16	91	1A1A5R45	7-16	117
1A1A5J7	7-16	66	1A1A5L45	7-16	92	1A1A5R46	7-16	117
1A1A5J8	7-16	65	1A1A5L46	7-16	93	1A1A5R47	7-16	117
1A1A5JMP1	7-16	67	1A1A5L47	7-16	93	1A1A5R48	7-16	117
1A1A5K1	7-16	68	1A1A5L48	7-16	94	1A1A5R49	7-16	117
1A1A5K2	7-16	68	1A1A5Q1	7-16	95	1A1A5R50	7-16	117
1A1A5K3	7-16	68	1A1A5Q2	7-16	96	1A1A5R51	7-16	117
1A1A5K4	7-16	68	1A1A5Q3	7-16	95	1A1A5RT1	7-16	124
1A1A5K5	7-16	68	1A1A5Q4	7-16	96	1A1A5T1	7-16	125
1A1A5K6	7-16	68	1A1A5Q5	7-16	97	1A1A5TP1	7-16	126
1A1A5K7	7-16	68	1A1A5R1	7-16	98	1A1A5TP2	7-16	127
1A1A5K8	7-16	68	1A1A5R2	7-16	99	1A1A5TP3	7-16	128
1A1A5K9	7-16	68	1A1A5R3	7-16	100	1A1A5U1	7-16	129
1A1A5K10	7-16	68	1A1A5R4	7-16	101	1A1A5Y1	7-16	130
1A1A5K11	7-16	68	1A1A5R5	7-16	101			
1A1A5K12	7-16	68	1A1A5R7	7-16	99	1A1A6	7-3	9
1A1A5K13	7-16	68	1A1A5R8	7-16	102	1A1A6AR1	7-17	2

Reference Designation	Fig No.	Index No.	Reference Designation	Fig No.	Index No.	Reference Designation	Fig No.	Index No.
1A1A6AR2	7-17	2	1A1A6C30	7-17	7	1A1A6CR9	7-17	12
1A1A6AR3	7-17	2	1A1A6C31	7-17	7	1A1A6CR10	7-17	12
1A1A6AR4	7-17	2	1A1A6C32	7-17	7	1A1A6CR11	7-17	12
1A1A6AR5	7-17	2	1A1A6C33	7-17	7	1A1A6CR12	7-17	12
1A1A6AR6	7-17	2	1A1A6C34	7-17	7	1A1A6CR13	7-17	12
1A1A6AR7	7-17	2	1A1A6C35	7-17	7	1A1A6CR14	7-17	12
1A1A6AR8	7-17	2	1A1A6C36	7-17	7	1A1A6CR15	7-17	12
1A1A6AR9	7-17	2	1A1A6C37	7-17	7	1A1A6CR16	7-17	12
1A1A6AR10	7-17	2	1A1A6C38	7-17	7	1A1A6CR17	7-17	12
1A1A6AR11	7-17	2	1A1A6C39	7-17	7	1A1A6CR18	7-17	12
1A1A6AR12	7-17	2	1A1A6C40	7-17	7	1A1A6CR19	7-17	12
1A1A6AR13	7-17	2	1A1A6C41	7-17	7	1A1A6CR20	7-17	12
1A1A6AR14	7-17	2	1A1A6C42	7-17	7	1A1A6CR21	7-17	12
1A1A6AR16	7-17	2	1A1A6C43	7-17	7	1A1A6CR22	7-17	13
1A1A6AR17	7-17	3	1A1A6C44	7-17	7	1A1A6CR23	7-17	12
1A1A6AR18	7-17	2	1A1A6C45	7-17	7	1A1A6CR24	7-17	12
1A1A6AR19	7-17	2	1A1A6C46	7-17	7	1A1A6CR25	7-17	12
1A1A6AR20	7-17	3	1A1A6C47	7-17	7	1A1A6CR26	7-17	12
1A1A6AR21	7-17	2	1A1A6C48	7-17	7	1A1A6CR27	7-17	12
1A1A6AR22	7-17	2	1A1A6C49	7-17	7	1A1A6CR28	7-17	12
1A1A6AR23	7-17	2	1A1A6C50	7-17	7	1A1A6CR29	7-17	12
1A1A6AR24	7-17	2	1A1A6C51	7-17	7	1A1A6CR30	7-17	12
1A1A6AR25	7-17	2	1A1A6C52	7-17	7	1A1A6CR31	7-17	12
1A1A6C1	7-17	4	1A1A6C53	7-17	7	1A1A6CR32	7-17	12
1A1A6C2	7-17	4	1A1A6C55	7-17	6	1A1A6CR33	7-17	12
1A1A6C3	7-17	4	1A1A6C56	7-17	6	1A1A6CR34	7-17	12
1A1A6C4	7-17	5	1A1A6C57	7-17	7	1A1A6CR35	7-17	12
1A1A6C6	7-17	6	1A1A6C58	7-17	7	1A1A6CR36	7-17	12
1A1A6C7	7-17	6	1A1A6C59	7-17	10	1A1A6CR37	7-17	13
1A1A6C8	7-17	6	1A1A6C61	7-17	5	1A1A6CR40	7-17	12
1A1A6C9	7-17	6	1A1A6C62	7-17	6	1A1A6CR42	7-17	12
1A1A6C10	7-17	4	1A1A6C63	7-17	5	1A1A6CR43	7-17	12
1A1A6C11	7-17	7	1A1A6C64	7-17	6	1A1A6CR44	7-17	12
1A1A6C12	7-17	7	1A1A6C65	7-17	7	1A1A6CR45	7-17	12
1A1A6C13	7-17	6	1A1A6C66	7-17	5	1A1A6CR46	7-17	12
1A1A6C14	7-17	6	1A1A6C67	7-17	6	1A1A6CR47	7-17	12
1A1A6C15	7-17	5	1A1A6C68	7-17	5	1A1A6CR48	7-17	12
1A1A6C16	7-17	6	1A1A6C69	7-17	5	1A1A6CR49	7-17	12
1A1A6C17	7-17	8	1A1A6C70	7-17	6	1A1A6CR50	7-17	12
1A1A6C18	7-17	9	1A1A6C71	7-17	7	1A1A6CR51	7-17	12
1A1A6C19	7-17	7	1A1A6C72	7-17	7	1A1A6CR52	7-17	12
1A1A6C20	7-17	7	1A1A6C73	7-17	5	1A1A6CR53	7-17	12
1A1A6C21	7-17	7	1A1A6C74	7-17	11	1A1A6CR54	7-17	12
1A1A6C22	7-17	5	1A1A6CR1	7-17	12	1A1A6CR55	7-17	12
1A1A6C23	7-17	5	1A1A6CR2	7-17	12	1A1A6CR56	7-17	12
1A1A6C24	7-17	5	1A1A6CR3	7-17	12	1A1A6CR57	7-17	12
1A1A6C25	7-17	7	1A1A6CR4	7-17	12	1A1A6CR58	7-17	12
1A1A6C26	7-17	5	1A1A6CR5	7-17	12	1A1A6CR59	7-17	12
1A1A6C27	7-17	7	1A1A6CR6	7-17	12	1A1A6CR60	7-17	12
1A1A6C28	7-17	7	1A1A6CR7	7-17	12	1A1A6CR61	7-17	12
1A1A6C29	7-17	7	1A1A6CR8	7-17	12	1A1A6CR62	7-17	12

Reference Designation	Fig No.	Index No.	Reference Designation	Fig No.	Index No.	Reference Designation	Fig No.	Index No.
1A1A6CR63	7-17	12	1A1A6R2	7-17	27	1A1A6R56	7-17	37
1A1A6CR64	7-17	12	1A1A6R3	7-17	28	1A1A6R60	7-17	48
1A1A6CR66	7-17	12	1A1A6R4	7-17	28	1A1A6R61	7-17	48
1A1A6CR67	7-17	12	1A1A6R5	7-17	29	1A1A6R62	7-17	37
1A1A6CR68	7-17	12	1A1A6R6	7-17	30	1A1A6R63	7-17	55
1A1A6CR69	7-17	12	1A1A6R7	7-17	31	1A1A6R64	7-17	56
1A1A6CR70	7-17	12	1A1A6R8	7-17	27	1A1A6R65	7-17	37
1A1A6CR71	7-17	12	1A1A6R9	7-17	28	1A1A6R66	7-17	57
1A1A6CR72	7-17	12	1A1A6R10	7-17	29	1A1A6R67	7-17	58
1A1A6CR73	7-17	12	1A1A6R11	7-17	32	1A1A6R68	7-17	59
1A1A6CR75	7-17	12	1A1A6R12	7-17	27	1A1A6R69	7-17	37
1A1A6CR76	7-17	12	1A1A6R13	7-17	33	1A1A6R70	7-17	42
1A1A6DS1	7-17	14	1A1A6R14	7-17	34	1A1A6R71	7-17	60
1A1A6DS2	7-17	15	1A1A6R15	7-17	35	1A1A6R72	7-17	60
1A1A6DS3	7-17	16	1A1A6R16	7-17	36	1A1A6R77	7-17	54
1A1A6J1	7-17	17	1A1A6R17	7-17	37	1A1A6R78	7-17	61
1A1A6L1	7-17	18	1A1A6R18	7-17	38	1A1A6R79	7-17	55
1A1A6L2	7-17	19	1A1A6R19	7-17	39	1A1A6R80	7-17	62
1A1A6L3	7-17	19	1A1A6R20	7-17	33	1A1A6R81	7-17	37
1A1A6L4	7-17	19	1A1A6R21	7-17	40	1A1A6R82	7-17	37
1A1A6L5	7-17	20	1A1A6R22	7-17	40	1A1A6R83	7-17	37
1A1A6L6	7-17	20	1A1A6R23	7-17	41	1A1A6R84	7-17	37
1A1A6L7	7-17	20	1A1A6R24	7-17	42	1A1A6R85	7-17	37
1A1A6L8	7-17	20	1A1A6R25	7-17	27	1A1A6R86	7-17	63
1A1A6L9	7-17	20	1A1A6R26	7-17	37	1A1A6R87	7-17	36
1A1A6P1A	7-17	21	1A1A6R27	7-17	43	1A1A6R88	7-17	34
1A1A6P1B	7-17	22	1A1A6R28	7-17	38	1A1A6R89	7-17	34
1A1A6Q1	7-17	23	1A1A6R32	7-17	44	1A1A6R90	7-17	34
1A1A6Q2	7-17	23	1A1A6R33	7-17	37	1A1A6R91	7-17	34
1A1A6Q3	7-17	24	1A1A6R34	7-17	37	1A1A6R92	7-17	36
1A1A6Q4	7-17	24	1A1A6R35	7-17	44	1A1A6R93	7-17	64
1A1A6Q5	7-17	24	1A1A6R36	7-17	45	1A1A6R94	7-17	37
1A1A6Q7	7-17	24	1A1A6R37	7-17	46	1A1A6R95	7-17	34
1A1A6Q9	7-17	24	1A1A6R38	7-17	47	1A1A6R96	7-17	50
1A1A6Q10	7-17	24	1A1A6R39	7-17	28	1A1A6R97	7-17	65
1A1A6Q11	7-17	25	1A1A6R40	7-17	48	1A1A6R98	7-17	49
1A1A6Q12	7-17	25	1A1A6R41	7-17	49	1A1A6R99	7-17	34
1A1A6Q13	7-17	24	1A1A6R42	7-17	49	1A1A6R100	7-17	34
1A1A6Q14	7-17	24	1A1A6R43	7-17	32	1A1A6R101	7-17	42
1A1A6Q16	7-17	24	1A1A6R44	7-17	48	1A1A6R102	7-17	66
1A1A6Q17	7-17	24	1A1A6R45	7-17	44	1A1A6R103	7-17	32
1A1A6Q18	7-17	24	1A1A6R46	7-17	50	1A1A6R104	7-17	37
1A1A6Q21	7-17	25	1A1A6R47	7-17	44	1A1A6R105	7-17	67
1A1A6Q23	7-17	25	1A1A6R48	7-17	51	1A1A6R106	7-17	68
1A1A6Q24	7-17	24	1A1A6R49	7-17	52	1A1A6R107	7-17	59
1A1A6Q25	7-17	24	1A1A6R50	7-17	34	1A1A6R108	7-17	37
1A1A6Q26	7-17	25	1A1A6R51	7-17	30	1A1A6R109	7-17	67
1A1A6Q27	7-17	24	1A1A6R52	7-17	39	1A1A6R110	7-17	37
1A1A6Q28	7-17	24	1A1A6R53	7-17	53	1A1A6R111	7-17	67
1A1A6Q29	7-17	24	1A1A6R54	7-17	54	1A1A6R112	7-17	37
1A1A6R1	7-17	26	1A1A6R55	7-17	49	1A1A6R113	7-17	67

Reference Designation	Fig No.	Index No.	Reference Designation	Fig No.	Index No.	Reference Designation	Fig No.	Index No.
1A1A6R114	7-17	69	1A1A6R166	7-17	77	1A1A6R221	7-17	34
1A1A6R115	7-17	37	1A1A6R167	7-17	78	1A1A6R222	7-17	100
1A1A6R116	7-17	64	1A1A6R168	7-17	79	1A1A6R226	7-17	101
1A1A6R117	7-17	37	1A1A6R169	7-17	80	1A1A6R227	7-17	102
1A1A6R118	7-17	36	1A1A6R170	7-17	81	1A1A6R228	7-17	66
1A1A6R119	7-17	70	1A1A6R171	7-17	82	1A1A6R229	7-17	37
1A1A6R120	7-17	68	1A1A6R173	7-17	42	1A1A6R230	7-17	44
1A1A6R121	7-17	36	1A1A6R174	7-17	83	1A1A6R231	7-17	44
1A1A6R122	7-17	37	1A1A6R175	7-17	67	1A1A6R232	7-17	37
1A1A6R123	7-17	30	1A1A6R176	7-17	83	1A1A6R233	7-17	32
UA1A6R124	7-17	30	1A1A6R177	7-17	49	1A1A6R234	7-17	103
1A1A6R125	7-17	59	1A1A6R178	7-17	42	1A1A6R235	7-17	59
1A1A6R126	7-17	49	1A1A6R179	7-17	83	1A1A6R236	7-17	104
1A1A6R127	7-17	49	1A1A6R180	7-17	49	1A1A6R237	7-17	95
1A1A6R128	7-17	67	1A1A6R181	7-17	37	1A1A6R238	7-17	62
1A1A6R129	7-17	59	1A1A6R182	7-17	84	1A1A6R239	7-17	62
1A1A6R130	7-17	71	1A1A6R183	7-17	85	1A1A6R240	7-17	32
1A1A6R131	7-17	72	1A1A6R186	7-17	37	1A1A6R241	7-17	87
1A1A6R132	7-17	49	1A1A6R187	7-17	34	1A1A6R242	7-17	32
1A1A6R133	7-17	54	1A1A6R188	7-17	86	1A1A6R243	7-17	32
1A1A6R134	7-17	49	1A1A6R189	7-17	87	1A1A6R244	7-17	32
1A1A6R135	7-17	34	1A1A6R190	7-17	37	1A1A6R245	7-17	105
1A1A6R136	7-17	37	1A1A6R192	7-17	50	1A1A6R246	7-17	106
1A1A6R137	7-17	34	1A1A6R193	7-17	34	1A1A6R247	7-17	37
1A1A6R138	7-17	37	1A1A6R194	7-17	38	1A1A6R248	7-17	60
1A1A6R139	7-17	55	1A1A6R195	7-17	88	1A1A6R249	7-17	32
1A1A6R140	7-17	39	1A1A6R196	7-17	34	1A1A6R250	7-17	59
1A1A6R141	7-17	40	1A1A6R197	7-17	59	1A1A6R251	7-17	95
1A1A6R142	7-17	29	1A1A6R198	7-17	89	1A1A6TP1	7-17	107
1A1A6R143	7-17	73	1A1A6R199	7-17	34	1A1A6TP2	7-17	108
1A1A6R144	7-17	74	1A1A6R200	7-17	90	1A1A6TP3	7-17	109
1A1A6R145	7-17	37	1A1A6R201	7-17	34	1A1A6TP4	7-17	110
1A1A6R146	7-17	42	1A1A6R202	7-17	91	1A1A6TP5	7-17	111
1A1A6R147	7-17	44	1A1A6R203	7-17	92	1A1A6TP6	7-17	112
1A1A6R148	7-17	36	1A1A6R204	7-17	93	1A1A6TP7	7-17	113
1A1A6R149	7-17	49	1A1A6R205	7-17	94	1A1A6TP8	7-17	114
1A1A6R150	7-17	59	1A1A6R206	7-17	34	1A1A6TP9	7-17	115
1A1A6R151	7-17	44	1A1A6R207	7-17	34	1A1A6TP10	7-17	116
1A1A6R152	7-17	37	1A1A6R208	7-17	95	1A1A6TP11	7-17	107
1A1A6R153	7-17	37	1A1A6R209	7-17	50	1A1A6TP12	7-17	108
1A1A6R154	7-17	37	1A1A6R210	7-17	96	1A1A6TP13	7-17	109
1A1A6R155	7-17	37	1A1A6R211	7-17	97	1A1A6TP15	7-17	117
1A1A6R156	7-17	37	1A1A6R212	7-17	34	1A1A6TP16	7-17	112
1A1A6R157	7-17	37	1A1A6R213	7-17	59	1A1A6TP17	7-17	113
1A1A6R158	7-17	59	1A1A6R214	7-17	89	1A1A6TP19	7-17	115
1A1A6R159	7-17	36	1A1A6R215	7-17	59	1A1A6TP20	7-17	116
1A1A6R161	7-17	37	1A1A6R216	7-17	83	1A1A6TP21	7-17	107
1A1A6R162	7-17	75	1A1A6R217	7-17	62	1A1A6TP22	7-17	108
1A1A6R163	7-17	28	1A1A6R218	7-17	98	1A1A6U1	7-17	118
1A1A6R164	7-17	42	1A1A6R219	7-17	34	1A1A6U4	7-17	119
1A1A6R165	7-17	76	1A1A6R220	7-17	99	1A1A6U5	7-17	120

Reference Designation	Fig No.	Index No.	Reference Designation	Fig No.	Index No.	Reference Designation	Fig No.	Index No.
1A1A6U6	7-17	120	1A1A7C30	7-18	17	1A1A7C84	7-18	6
1A1A6U7	7-17	121	1A1A7C31	7-18	18	1A1A7C85	7-18	30
1A1A6U8	7-17	122	1A1A7C32	7-18	19	1A1A7C86	7-18	15
1A1A6U9	7-17	123	1A1A7C34	7-18	20	1A1A7C87	7-18	15
1A1A6U10	7-17	124	1A1A7C36	7-18	20	1A1A7C88	7-18	28
1A1A6U11	7-17	125	1A1A7C37	7-18	14	1A1A7C89	7-18	14
1A1A6U12	7-17	122	1A1A7C38	7-18	14	1A1A7C90	7-18	14
1A1A6VR1	7-17	126	1A1A7C39	7-18	14	1A1A7C91	7-18	6
1A1A6VR2	7-17	127	1A1A7C40	7-18	14	1A1A7C92	7-18	32
1A1A7	7-1	20	1A1A7C41	7-18	14	1A1A7C93	7-18	7
1A1A7AR1	7-18	1	1A1A7C42	7-18	15	1A1A7C94	7-18	7
1A1A7AR2	7-18	2	1A1A7C43	7-18	14	1A1A7C95	7-18	14
1A1A7AR3	7-18	3	1A1A7C44	7-18	21	1A1A7C96	7-18	28
1A1A7AR4	7-18	2	1A1A7C45	7-18	14	1A1A7C97	7-18	7
1A1A7AR5	7-18	2	1A1A7C46	7-18	14	1A1A7C98	7-18	30
1A1A7AR6	7-18	2	1A1A7C47	7-18	14	1A1A7C99	7-18	7
1A1A7AR7	7-18	2	1A1A7C48	7-18	15	1A1A7C100	7-18	7
1A1A7AR8	7-18	2	1A1A7C49	7-18	14	1A1A7C101	7-18	33
1A1A7AR9	7-18	2	1A1A7C50	7-18	14	1A1A7C102	7-18	34
1A1A7AR10	7-18	2	1A1A7C51	7-18	7	1A1A7C103	7-18	15
1A1A7AR11	7-18	4	1A1A7C52	7-18	14	1A1A7C104	7-18	14
1A1A7AR12	7-18	3	1A1A7C53	7-18	15	1A1A7C105	7-18	35
1A1A7C1	7-18	5	1A1A7C54	7-18	14	1A1A7C106	7-18	36
1A1A7C2	7-18	6	1A1A7C55	7-18	14	1A1A7C107	7-18	15
1A1A7C3	7-18	6	1A1A7C56	7-18	22	1A1A7C108	7-18	30
1A1A7C4	7-18	7	1A1A7C57	7-18	23	1A1A7C109	7-18	14
1A1A7C5	7-18	6	1A1A7C58	7-18	24	1A1A7C110	7-18	21
1A1A7C6	7-18	6	1A1A7C59	7-18	25	1A1A7C111	7-18	30
1A1A7C7	7-18	6	1A1A7C60	7-18	14	1A1A7C112	7-18	7
1A1A5C8	7-18	8	1A1A7C61	7-18	14	1A1A7C113	7-18	15
1A1A7C9	7-18	6	1A1A7C62	7-18	14	1A1A7C114	7-18	37
1A1A7C10	7-18	7	1A1A7C63	7-18	26	1A1A7C115	7-18	37
1A1A7C11	7-18	6	1A1A7C64	7-18	14	1A1A7C116	7-18	30
1A1A7C12	7-18	7	1A1A7C66	7-18	14	1A1A7C117	7-18	32
1A1A7C13	7-18	6	1A1A7C67	7-18	14	1A1A7C118	7-18	6
1A1A7C14	7-18	7	1A1A7C68	7-18	27	1A1A7C119	7-18	38
1A1A7C15	7-18	9	1A1A7C69	7-18	20	1A1A7C120	7-18	15
1A1A7C16	7-18	10	1A1A7C70	7-18	28	1A1A7C121	7-18	15
1A1A7C17	7-18	11	1A1A7C71	7-18	20	1A1A7C123	7-18	15
1A1A7C18	7-18	12	1A1A7C72	7-18	15	1A1A7C124	7-18	15
1A1A7C20	7-18	13	1A1A7C73	7-18	14	1A1A7C125	7-18	15
1A1A7C21	7-18	14	1A1A7C74	7-18	14	1A1A7C126	7-18	15
1A1A7C22	7-18	14	1A1A7C75	7-18	15	1A1A7C127	7-18	15
1A1A7C23	7-18	14	1A1A7C76	7-18	7	1A1A7C128	7-18	15
1A1A7C24	7-18	15	1A1A7C77	7-18	15	1A1A7C129	7-18	15
1A1A7C25	7-18	14	1A1A7C78	7-18	29	1A1A7C130	7-18	15
1A1A7C26	7-18	14	1A1A7C79	7-18	15	1A1A7C131	7-18	15
1A1A7C27	7-18	14	1A1A7C80	7-18	30	1A1A7C132	7-18	15
1A1A7C28	7-18	15	1A1A7C81	7-18	31	1A1A7C133	7-18	15
1A1A7C29	7-18	16	1A1A7C82	7-18	30	1A1A7C134	7-18	15
			1A1A7C83	7-18	6	1A1A7C135	7-18	30

Reference Designation	Flg No.	Index No.	Reference Designation	Flg No.	Index No.	Reference Designation	Flg No.	Index No.
1A1A7C137	7-18	6	1A1A7J2	7-18	45	1A1A7Q11	7-18	73
1A1A7C138	7-18	6	1A1A7J3	7-18	45	1A1A7Q12	7-18	74
1A1A7C139	7-18	6	1A1A7J4	7-18	46	1A1A7Q13	7-18	73
1A1A7C140	7-18	14	1A1A7J5	7-18	45	1A1A7Q14	7-18	73
1A1A7C141	7-18	7	1A1A7J6	7-18	45	1A1A7Q15	7-18	73
1A1A7C142	7-18	7	1A1A7J7	7-18	46	1A1A7Q16	7-18	73
1A1A7C143	7-18	39	1A1A7J8	7-18	47	1A1A7Q18	7-18	73
1A1A7C144	7-18	39	1A1A7J9	7-18	48	1A1A7Q19	7-18	75
1A1A7C145	7-18	40	1A1A7J11	7-18	49	1A1A7Q20	7-18	76
1A1A7C146	7-18	7	1A1A7JMP1	7-18	50	1A1A7Q24	7-18	75
1A1A7C147	7-18	6	1A1A7L1	7-18	51	1A1A7Q25	7-18	77
1A1A7C148	7-18	6	1A1A7L2	7-18	52	1A1A7Q26	7-18	73
1A1A7CR1	7-18	41	1A1A7L3	7-18	51	1A1A7Q27	7-18	73
1A1A7CR2	7-18	41	1A1A7L4	7-18	53	1A1A7R1	7-18	78
1A1A7CR3	7-18	42	1A1A7L5	7-18	51	1A1A7R2	7-18	79
1A1A7CR4	7-18	42	1A1A7L6	7-18	54	1A1A7R3	7-18	80
1A1A7CR5	7-18	43	1A1A7L7	7-18	55	1A1A7R4	7-18	81
1A1A7CR6	7-18	43	1A1A7L8	7-18	55	1A1A7R5	7-18	82
1A1A7CR7	7-18	42	1A1A7L9	7-18	56	1A1A7R6	7-18	83
1A1A7CR8	7-18	42	1A1A7L10	7-18	57	1A1A7R7	7-18	84
1A1A7CR9	7-18	41	1A1A7L11	7-18	58	1A1A7R8	7-18	84
1A1A7CR10	7-18	41	1A1A7L12	7-18	56	1A1A7R9	7-18	84
1A1A7CR11	7-18	41	1A1A7L13	7-18	59	1A1A7R10	7-18	84
1A1A7CR12	7-18	43	1A1A7L17	7-18	60	1A1A7R12	7-18	85
1A1A7CR13	7-18	43	1A1A7L18	7-18	61	1A1A7R13	7-18	86
1A1A7CR14	7-18	43	1A1A7L19	7-18	60	1A1A7R14	7-18	84
1A1A7CR15	7-18	43	1A1A7L24	7-18	62	1A1A7R15	7-18	87
1A1A7CR16	7-18	43	1A1A7L25	7-18	63	1A1A7R16	7-18	88
1A1A7CR17	7-18	43	1A1A7L26	7-18	64	1A1A7R17	7-18	89
1A1A7CR18	7-18	43	1A1A7L27	7-18	65	1A1A7R18	7-18	90
1A1A7CR19	7-18	43	1A1A7L28	7-18	64	1A1A7R19	7-18	91
1A1A7CR20	7-18	43	1A1A7L29	7-18	66	1A1A7R20	7-18	87
1A1A7CR21	7-18	43	1A1A7L30	7-18	67	1A1A7R21	7-18	89
1A1A7CR22	7-18	43	1A1A7L32	7-18	68	1A1A7R22	7-18	87
1A1A7CR23	7-18	43	1A1A7L33	7-18	64	1A1A7R23	7-18	92
1A1A7CR24	7-18	43	1A1A7L35	7-18	51	1A1A7R24	7-18	93
1A1A7CR25	7-18	43	1A1A7L36	7-18	55	1A1A7R25	7-18	94
1A1A7CR26	7-18	43	1A1A7L37	7-18	55	1A1A7R26	7-18	91
1A1A7CR27	7-18	43	1A1A7L38	7-18	55	1A1A7R29	7-18	84
1A1A7CR28	7-18	43	1A1A7L39	7-18	64	1A1A7R31	7-18	84
1A1A7CR29	7-18	43	1A1A7L40	7-18	69	1A1A7R32	7-18	95
1A1A7CR30	7-18	43	1A1A7L41	7-18	69	1A1A7R33	7-18	96
1A1A7CR31	7-18	43	1A1A7P1	7-18	70	1A1A7R34	7-18	89
1A1A7CR32	7-18	43	1A1A7Q1	7-18	71	1A1A7R35	7-18	89
1A1A7CR33	7-18	43	1A1A7Q4	7-18	72	1A1A7R36	7-18	97
1A1A7CR34	7-18	43	1A1A7Q5	7-18	73	1A1A7R37	7-18	84
1A1A7CR35	7-18	43	1A1A7Q6	7-18	73	1A1A7R38	7-18	87
1A1A7CR36	7-18	43	1A1A7Q7	7-18	73	1A1A7R39	7-18	88
1A1A7CR37	7-18	43	1A1A7Q8	7-18	71	1A1A7R40	7-18	98
1A1A7CR38	7-18	43	1A1A7Q9	7-18	73	1A1A7R41	7-18	99
1A1A7J1	7-18	44	1A1A7Q10	7-18	73	1A1A7R42	7-18	100

Reference Designation	Fig No.	Index No.	Reference Designation	Fig No.	Index No.	Reference Designation	Fig No.	Index No.
1A1A7R43	7-18	91	1A1A7R96	7-18	104	1A1A7R157	7-18	132
1A1A7R44	7-18	97	1A1A7R97	7-18	115	1A1A7R158	7-18	132
1A1A7R45	7-18	87	1A1A7R98	7-18	109	1A1A7R159	7-18	132
1A1A7R46	7-18	88	1A1A7R99	7-18	115	1A1A7R160	7-18	132
1A1A7R47	7-18	101	1A1A7R100	7-18	115	1A1A7R161	7-18	87
1A1A7R48	7-18	91	1A1A7R101	7-18	87	1A1A7R162	7-18	87
1A1A7R49	7-18	99	1A1A7R102	7-18	116	1A1A7R163	7-18	87
1A1A7R50	7-18	91	1A1A7R103	7-18	117	1A1A7R164	7-18	88
1A1A7R51	7-18	101	1A1A7R107	7-18	109	1A1A7R165	7-18	87
1A1A7R52	7-18	97	1A1A7R108	7-18	96	1A1A7R166	7-18	115
1A1A7R53	7-18	87	1A1A7R109	7-18	115	1A1A7R167	7-18	96
1A1A7R54	7-18	88	1A1A7R110	7-18	118	1A1A7R168	7-18	133
1A1A7R55	7-18	89	1A1A7R111	7-18	96	1A1A7R169	7-18	86
1A1A7R56	7-18	99	1A1A7R115	7-18	97	1A1A7R170	7-18	96
1A1A7R57	7-18	102	1A1A7R117	7-18	119	1A1A7R171	7-18	134
1A1A7R58	7-18	87	1A1A7R118	7-18	120	1A1A7R172	7-18	101
1A1A7R59	7-18	87	1A1A7R119	7-18	107	1A1A7R173	7-18	87
1A1A7R60	7-18	103	1A1A7R120	7-18	87	1A1A7R174	7-18	87
1A1A7R61	7-18	93	1A1A7R121	7-18	106	1A1A7R175	7-18	115
1A1A7R62	7-18	93	1A1A7R122	7-18	121	1A1A7R176	7-18	87
1A1A7R63	7-18	84	1A1A7R123	7-18	118	1A1A7R177	7-18	87
1A1A7R64	7-18	104	1A1A7R126	7-18	115	1A1A7R178	7-18	87
1A1A7R65	7-18	93	1A1A7R128	7-18	122	1A1A7R179	7-18	87
1A1A7R66	7-18	105	1A1A7R129	7-18	123	1A1A7R180	7-18	96
1A1A7R67	7-18	94	1A1A7R130	7-18	96	1A1A7R181	7-18	88
1A1A7R68	7-18	106	1A1A7R131	7-18	124	1A1A7R182	7-18	97
1A1A7R69	7-18	91	1A1A7R132	7-18	124	1A1A7R183	7-18	107
1A1A7R70	7-18	95	1A1A7R133	7-18	110	1A1A7R184	7-18	85
1A1A7R72	7-18	105	1A1A7R134	7-18	87	1A1A7R185	7-18	125
1A1A7R73	7-18	107	1A1A7R135	7-18	125	1A1A7R186	7-18	87
1A1A7R74	7-18	87	1A1A7R136	7-18	95	1A1A7R187	7-18	87
1A1A7R75	7-18	87	1A1A7R137	7-18	89	1A1A7R188	7-18	87
1A1A7R76	7-18	108	1A1A7R138	7-18	126	1A1A7R189	7-18	87
1A1A7R77	7-18	109	1A1A7R139	7-18	87	1A1A7R190	7-18	87
1A1A7R78	7-18	87	1A1A7R140	7-18	97	1A1A7R191	7-18	107
1A1A7R79	7-18	110	1A1A7R141	7-18	127	1A1A7R192	7-18	107
1A1A7R80	7-18	89	1A1A7R142	7-18	112	1A1A7R193	7-18	87
1A1A7R81	7-18	111	1A1A7R143	7-18	96	1A1A7R194	7-18	88
1A1A7R82	7-18	110	1A1A7R144	7-18	128	1A1A7R195	7-18	87
1A1A7R83	7-18	97	1A1A7R145	7-18	129	1A1A7R196	7-18	115
1A1A7R84	7-18	88	1A1A7R146	7-18	107	1A1A7R197	7-18	135
1A1A7R85	7-18	107	1A1A7R147	7-18	104	1A1A7R198	7-18	95
1A1A7R86	7-18	107	1A1A7R148	7-18	87	1A1A7T1	7-18	136
1A1A7R87	7-18	84	1A1A7R149	7-18	130	1A1A7T2	7-18	137
1A1A7R88	7-18	89	1A1A7R150	7-18	131	1A1A7TP1	7-18	138
1A1A7R90	7-18	112	1A1A7R151	7-18	89	1A1A7TP2	7-18	138
1A1A7R91	7-18	112	1A1A7R152	7-18	104	1A1A7TP3	7-18	138
1A1A7R92	7-18	86	1A1A7R153	7-18	87	1A1A7U1	7-18	139
1A1A7R93	7-18	113	1A1A7R154	7-18	96	1A1A7U2	7-18	139
1A1A7R94	7-18	114	1A1A7R155	7-18	91	1A1A7U4	7-18	140
1A1A7R95	7-18	87	1A1A7R156	7-18	89	1A1A7U5	7-18	140

Reference Designation	Fig No.	Index No.	Reference Designation	Fig No.	Index No.	Reference Designation	Fig No.	Index No.
1A1A7U18	7-18	141	1A1A9C45	7-20	6	1A1A9CR4	7-20	29
1A1A7U19	7-18	141	1A1A9C46	7-20	6	1A1A9CR5	7-20	29
1A1A7U20	7-18	142	1A1A9C47	7-20	20	1A1A9CR6	7-20	29
1A1A7U22	7-18	143	1A1A9C48	7-20	21	1A1A9CR7	7-20	29
1A1A7U23	7-18	144	1A1A9C49	7-20	22	1A1A9CR8	7-20	29
1A1A7VR2	7-18	145	1A1A9C50	7-20	23	1A1A9CR9	7-20	29
1A1A7Y1	7-18	146	1A1A9C51	7-20	20	1A1A9CR10	7-20	29
			1A1A9C52	7-20	24	1A1A9CR11	7-20	30
1A1A8	7-5	6	1A1A9C53	7-20	10	1A1A9CR12	7-20	30
1A1A8P1	7-19	3	1A1A9C54	7-20	10	1A1A9CR13	7-20	30
			1A1A9C55	7-20	10	1A1A9CR14	7-20	30
1A1A9	7-3	10	1A1A9C56	7-20	10	1A1A9CR15	7-20	31
1A1A9AR1	7-20	4	1A1A9C57	7-20	6	1A1A9CR16	7-20	31
1A1A9C1	7-20	5	1A1A9C58	7-20	10	1A1A9CR17	7-20	32
1A1A9C2	7-20	6	1A1A9C59	7-20	10	1A1A9CR18	7-20	32
1A1A9C3	7-20	6	1A1A9C60	7-20	10	1A1A9CR21	7-20	32
1A1A9C4	7-20	6	1A1A9C61	7-20	10	1A1A9CR22	7-20	32
1A1A9C5	7-20	7	1A1A9C62	7-20	10	1A1A9CR23	7-20	32
1A1A9C6	7-20	8	1A1A9C63	7-20	10	1A1A9CR24	7-20	32
1A1A9C7	7-20	9	1A1A9C64	7-20	10	1A1A9CR25	7-20	32
1A1A9C8	7-20	10	1A1A9C65	7-20	25	1A1A9CR27	7-20	32
1A1A9C9	7-20	6	1A1A9C66	7-20	16	1A1A9CR28	7-20	32
1A1A9C10	7-20	6	1A1A9C67	7-20	10	1A1A9CR29	7-20	32
1A1A9C11	7-20	6	1A1A9C68	7-20	10	1A1A9J1	7-20	33
1A1A9C12	7-20	10	1A1A9C69	7-20	14	1A1A9J2	7-20	34
1A1A9C19	7-20	11	1A1A9C70	7-20	10	1A1A9J3	7-20	35
1A1A9C20	7-20	12	1A1A9C72	7-20	10	1A1A9J4	7-20	35
1A1A9C21	7-20	13	1A1A9C73	7-20	10	1A1A9J5	7-20	35
1A1A9C22	7-20	14	1A1A9C74	7-20	10	1A1A9J6	7-20	35
1A1A9C23	7-20	14	1A1A9C75	7-20	10	1A1A9J7	7-20	35
1A1A9C24	7-20	14	1A1A9C76	7-20	10	1A1A9J9	7-20	34
1A1A9C25	7-20	10	1A1A9C77	7-20	10	1A1A9JMP1	7-20	36
1A1A9C26	7-20	14	1A1A9C78	7-20	10	1A1A9L1	7-20	37
1A1A9C27	7-20	6	1A1A9C79	7-20	10	1A1A9L2	7-20	38
1A1A9C28	7-20	15	1A1A9C80	7-20	10	1A1A9L4	7-20	39
1A1A9C29	7-20	10	1A1A9C81	7-20	26	1A1A9L5	7-20	40
1A1A9C30	7-20	16	1A1A9C82	7-20	25	1A1A9L6	7-20	41
1A1A9C31	7-20	12	1A1A9C83	7-20	25	1A1A9L7	7-20	42
1A1A9C32	7-20	17	1A1A9C84	7-20	10	1A1A9L8	7-20	43
1A1A9C33	7-20	14	1A1A9C85	7-20	10	1A1A9L9	7-20	43
1A1A9C34	7-20	18	1A1A9C86	7-20	10	1A1A9L10	7-20	43
1A1A9C35	7-20	19	1A1A9C87	7-20	6	1A1A9L11	7-20	42
1A1A9C36	7-20	18	1A1A9C88	7-20	6	1A1A9L12	7-20	42
1A1A9C37	7-20	6	1A1A9C89	7-20	6	1A1A9L13	7-20	44
1A1A9C38	7-20	15	1A1A9C90	7-20	15	1A1A9P1	7-20	45
1A1A9C39	7-20	10	1A1A9C91	7-20	10	1A1A9P2	7-20	46
1A1A9C40	7-20	10	1A1A9C92	7-20	27	1A1A9Q1	7-20	47
1A1A9C41	7-20	6	1A1A9C93	7-20	6	1A1A9Q2	7-20	48
1A1A9C42	7-20	6	1A1A9CR1	7-20	28	1A1A9Q3	7-20	49
1A1A9C43	7-20	6	1A1A9CR2	7-20	29	1A1A9Q4	7-20	47
1A1A9C44	7-20	6	1A1A9CR3	7-20	29	1A1A9Q6	7-20	50



Reference Designation	Fig No.	Index No.	Reference Designation	Fig No.	Index No.	Reference Designation	Fig No.	Index No.
1A1A9Q7	7-20	50	1A1A9R46	7-20	58	1A1A9R103	7-20	76
1A1A9Q8	7-20	51	1A1A9R47	7-20	68	1A1A9R104	7-20	59
1A1A9Q9	7-20	51	1A1A9R48	7-20	69	1A1A9R105	7-20	84
1A1A9Q10	7-20	50	1A1A9R49	7-20	70	1A1A9R106	7-20	67
1A1A9Q11	7-20	51	1A1A9R50	7-20	71	1A1A9R107	7-20	76
1A1A9Q12	7-20	50	1A1A9R51	7-20	69	1A1A9R108	7-20	85
1A1A9Q13	7-20	51	1A1A9R52	7-20	69	1A1A9T1	7-20	86
1A1A9Q14	7-20	49	1A1A9R53	7-20	72	1A1A9TP1	7-20	87
1A1A9Q15	7-20	49	1A1A9R54	7-20	57	1A1A9TP2	7-20	88
1A1A9Q16	7-20	51	1A1A9R55	7-20	73	1A1A9U1	7-20	89
1A1A9Q17	7-20	50	1A1A9R56	7-20	58	1A1A9U2	7-20	89
1A1A9Q18	7-20	49	1A1A9R57	7-20	74	1A1A9U3	7-20	89
1A1A9Q19	7-20	51	1A1A9R58	7-20	75	1A1A9U4	7-20	89
1A1A9Q20	7-20	50	1A1A9R59	7-20	76	1A1A9U5	7-20	90
1A1A9Q21	7-20	49	1A1A9R60	7-20	77	1A1A9U6	7-20	91
1A1A9Q22	7-20	52	1A1A9R62	7-20	78	1A1A9U7	7-20	92
1A1A9R1	7-20	53	1A1A9R63	7-20	57	1A1A9U8	7-20	93
1A1A9R2	7-20	54	1A1A9R64	7-20	54	1A1A9U9	7-20	94
1A1A9R3	7-20	55	1A1A9R65	7-20	54	1A1A9U10	7-20	95
1A1A9R4	7-20	56	1A1A9R66	7-20	53	1A1A9U11	7-20	96
1A1A9R5	7-20	57	1A1A9R67	7-20	57	1A1A9U12	7-20	96
1A1A9R6	7-20	58	1A1A9R68	7-20	58	1A1A9U13	7-20	97
1A1A9R8	7-20	59	1A1A9R69	7-20	79	1A1A9U14	7-20	91
1A1A9R9	7-20	54	1A1A9R70	7-20	63			
1A1A9R10	7-20	53	1A1A9R71	7-20	63	1A1A10	7-3	11
1A1A9R11	7-20	60	1A1A9R72	7-20	80	1A1A10A1	7-21	3
1A1A9R12	7-20	61	1A1A9R73	7-20	57	1A1A10A1C1	7-22	1
1A1A9R13	7-20	59	1A1A9R74	7-20	79	1A1A10A1C2	7-22	2
1A1A9R14	7-20	62	1A1A9R75	7-20	62	1A1A10A1C3	7-22	3
1A1A9R15	7-20	63	1A1A9R76	7-20	54	1A1A10A1C4	7-22	3
1A1A9R16	7-20	63	1A1A9R77	7-20	53	1A1A10A1C5	7-22	3
1A1A9R17	7-20	63	1A1A9R82	7-20	59	1A1A10A1C6	7-22	3
1A1A9R24	7-20	64	1A1A9R83	7-20	54	1A1A10A1C7	7-22	3
1A1A9R25	7-20	64	1A1A9R84	7-20	53	1A1A10A1C8	7-22	4
1A1A9R26	7-20	54	1A1A9R85	7-20	81	1A1A10A1C9	7-22	5
1A1A9R27	7-20	54	1A1A9R86	7-20	59	1A1A10A1C10	7-22	3
1A1A9R28	7-20	54	1A1A9R87	7-20	62	1A1A10A1C11	7-22	5
1A1A9R29	7-20	57	1A1A9R88	7-20	54	1A1A10A1C12	7-22	5
1A1A9R30	7-20	65	1A1A9R89	7-20	60	1A1A10A1C13	7-22	3
1A1A9R31	7-20	54	1A1A9R90	7-20	65	1A1A10A1C14	7-22	4
1A1A9R32	7-20	53	1A1A9R91	7-20	82	1A1A10A1C15	7-22	5
1A1A9R34	7-20	54	1A1A9R92	7-20	64	1A1A10A1C16	7-22	6
1A1A9R35	7-20	54	1A1A9R93	7-20	64	1A1A10A1C17	7-22	6
1A1A9R36	7-20	53	1A1A9R94	7-20	54	1A1A10A1C18	7-22	7
1A1A9R37	7-20	53	1A1A9R96	7-20	58	1A1A10A1C19	7-22	3
1A1A9R38	7-20	54	1A1A9R97	7-20	57	1A1A10A1C20	7-22	7
1A1A9R39	7-20	53	1A1A9R98	7-20	83	1A1A10A1C21	7-22	8
1A1A9R41	7-20	64	1A1A9R99	7-20	78	1A1A10A1C22	7-22	6
1A1A9R42	7-20	66	1A1A9R100	7-20	54	1A1A10A1C23	7-22	6
1A1A9R43	7-20	67	1A1A9R101	7-20	62	1A1A10A1C24	7-22	6
1A1A9R44	7-20	54	1A1A9R102	7-20	75	1A1A10A1C25	7-22	6

Reference Designation	Fig No.	Index No.	Reference Designation	Fig No.	Index No.	Reference Designation	Fig No.	Index No.
1A1A10A1C26	7-22	6	1A1A10A1R9	7-22	32	1A1A10C35	7-21	5
1A1A10A1C27	7-22	9	1A1A10A1R10	7-22	33	1A1A10C36	7-21	9
1A1A10A1C28	7-22	3	1A1A10A1R11	7-22	31	1A1A10C37	7-21	5
1A1A10A1C29	7-22	6	1A1A10A1R12	7-22	34	1A1A10C38	7-21	9
1A1A10A1C30	7-22	6	1A1A10A1R13	7-22	35	1A1A10C39	7-21	9
1A1A10A1CR1	7-22	10	1A1A10A1R14	7-22	36	1A1A10C40	7-21	8
1A1A10A1CR2	7-22	10	1A1A10A1R15	7-22	37	1A1A10C41	7-21	11
1A1A10A1CR3	7-22	10	1A1A10A1R16	7-22	34	1A1A10C42	7-21	12
1A1A10A1CR4	7-22	11	1A1A10A1R17	7-22	38	1A1A10C43	7-21	5
1A1A10A1CR5	7-22	11	1A1A10A1T1	7-22	39	1A1A10C44	7-21	13
1A1A10A1CR6	7-22	11	1A1A10A1T2	7-22	40	1A1A10C45	7-21	14
1A1A10A1CR7	7-22	11	1A1A10A1T3	7-22	41	1A1A10C46	7-21	10
1A1A10A1CR8	7-22	11	1A1A10A1T4	7-22	41	1A1A10C47	7-21	10
1A1A10A1CR9	7-22	11	1A1A10A1VR1	7-22	42	1A1A10C48	7-21	15
1A1A10A1CR10	7-22	11	1A1A10A1W1P1	7-22	21	1A1A10C49	7-21	16
1A1A10A1CR11	7-22	11	1A1A10AR1	7-21	4	1A1A10C50	7-21	17
1A1A10A1CR12	7-22	11	1A1A10AR2	7-21	4	1A1A10C51	7-21	5
1A1A10A1CR13	7-22	11	1A1A10C1	7-21	5	1A1A10C52	7-21	5
1A1A10A1CR14	7-22	11	1A1A10C2	7-21	6	1A1A10C53	7-21	6
1A1A10A1CR15	7-22	11	1A1A10C3	7-21	5	1A1A10C54	7-21	10
1A1A10A1CR16	7-22	11	1A1A10C4	7-21	7	1A1A10C55	7-21	10
1A1A10A1CR17	7-22	11	1A1A10C5	7-21	5	1A1A10C56	7-21	16
1A1A10A1CR18	7-22	12	1A1A10C6	7-21	8	1A1A10C57	7-21	5
1A1A10A1CR19	7-22	13	1A1A10C7	7-21	5	1A1A10C58	7-21	5
1A1A10A1J1	7-22	14	1A1A10C8	7-21	7	1A1A10C59	7-21	5
1A1A10A1J2	7-22	15	1A1A10C9	7-21	5	1A1A10C60	7-21	5
1A1A10A1J3	7-22	15	1A1A10C10	7-21	5	1A1A10C61	7-21	10
1A1A10A1JMP1	7-22	16	1A1A10C11	7-21	5	1A1A10C62	7-21	10
1A1A10A1L1	7-22	17	1A1A10C12	7-21	5	1A1A10C63	7-21	6
1A1A10A1L2	7-22	18	1A1A10C13	7-21	5	1A1A10C64	7-21	5
1A1A10A1L3	7-22	18	1A1A10C14	7-21	5	1A1A10C65	7-21	10
1A1A10A1L4	7-22	18	1A1A10C15	7-21	5	1A1A10C66	7-21	5
1A1A10A1L5	7-22	18	1A1A10C16	7-21	5	1A1A10C67	7-21	18
1A1A10A1L6	7-22	19	1A1A10C17	7-21	9	1A1A10C68	7-21	5
1A1A10A1L7	7-22	20	1A1A10C18	7-21	10	1A1A10C69	7-21	10
1A1A10A1L8	7-22	21	1A1A10C19	7-21	5	1A1A10C70	7-21	10
1A1A10A1L9	7-22	17	1A1A10C20	7-21	10	1A1A10C71	7-21	5
1A1A10A1L10	7-22	22	1A1A10C21	7-21	5	1A1A10C72	7-21	6
1A1A10A1L11	7-22	23	1A1A10C22	7-21	7	1A1A10C73	7-21	19
1A1A10A1Q1	7-22	24	1A1A10C23	7-21	5	1A1A10C74	7-21	10
1A1A10A1Q2	7-22	24	1A1A10C24	7-21	10	1A1A10C101	7-21	5
1A1A10A1Q3	7-22	24	1A1A10C25	7-21	10	1A1A10C102	7-21	6
1A1A10A1Q4	7-22	24	1A1A10C26	7-21	10	1A1A10C103	7-21	8
1A1A10A1R1	7-22	25	1A1A10C27	7-21	5	1A1A10C104	7-21	6
1A1A10A1R2	7-22	26	1A1A10C28	7-21	5	1A1A10C106	7-21	5
1A1A10A1R3	7-22	27	1A1A10C29	7-21	5	1A1A10C108	7-21	5
1A1A10A1R4	7-22	28	1A1A10C30	7-21	5	1A1A10C109	7-21	5
1A1A10A1R5	7-22	29	1A1A10C31	7-21	5	1A1A10C110	7-21	5
1A1A10A1R6	7-22	30	1A1A10C32	7-21	5	1A1A10C112	7-21	20
1A1A10A1R7	7-22	30	1A1A10C33	7-21	5	1A1A10C113	7-21	20
1A1A10A1R8	7-22	31	1A1A10C34	7-21	5	1A1A10C114	7-21	20

Reference Designation	Fig No.	Index No.	Reference Designation	Fig No.	Index No.	Reference Designation	Fig No.	Index No.
1A1A10C115	7-21	5	1A1A10Q12	7-21	41	1A1A10R21	7-21	63
1A1A10CR1	7-21	21	1A1A10Q13	7-21	44	1A1A10R22	7-21	58
1A1A10CR2	7-21	21	1A1A10Q14	7-21	41	1A1A10R23	7-21	56
1A1A10CR3	7-21	22	1A1A10Q15	7-21	41	1A1A10R24	7-21	62
1A1A10CR4	7-21	22	1A1A10Q16	7-21	45	1A1A10R25	7-21	64
1A1A10CR5	7-21	22	1A1A10Q17	7-21	43	1A1A10R26	7-21	57
1A1A10CR6	7-21	21	1A1A10Q18	7-21	46	1A1A10R27	7-21	64
1A1A10CR7	7-21	21	1A1A10Q19	7-21	45	1A1A10R28	7-21	65
1A1A10CR8	7-21	21	1A1A10Q20	7-21	47	1A1A10R29	7-21	66
1A1A10CR9	7-21	21	1A1A10Q21	7-21	47	1A1A10R30	7-21	67
1A1A10CR10	7-21	21	1A1A10Q22	7-21	43	1A1A10R31	7-21	68
1A1A10CR11	7-21	21	1A1A10Q23	7-21	48	1A1A10R32	7-21	60
1A1A10CR12	7-21	22	1A1A10Q24	7-21	48	1A1A10R33	7-21	56
1A1A10CR13	7-21	23	1A1A10Q25	7-21	47	1A1A10R34	7-21	56
1A1A10CR14	7-21	23	1A1A10Q26	7-21	47	1A1A10R36	7-21	56
1A1A10CR15	7-21	24	1A1A10Q27	7-21	43	1A1A10R37	7-21	56
1A1A10J1	7-21	25	1A1A10Q28	7-21	41	1A1A10R38	7-21	56
1A1A10J2	7-21	26	1A1A10Q29	7-21	49	1A1A10R40	7-21	56
1A1A10J3	7-21	27	1A1A10Q30	7-21	47	1A1A10R41	7-21	58
1A1A10J4	7-21	27	1A1A10Q31	7-21	47	1A1A10R42	7-21	59
1A1A10J5	7-21	28	1A1A10Q32	7-21	43	1A1A10R43	7-21	65
1A1A10J6	7-21	29	1A1A10Q33	7-21	47	1A1A10R44	7-21	65
1A1A10J7	7-21	29	1A1A10Q34	7-21	43	1A1A10R45	7-21	69
1A1A10J8	7-21	29	1A1A10Q35	7-21	47	1A1A10R46	7-21	61
1A1A10L1	7-21	30	1A1A10Q36	7-21	47	1A1A10R47	7-21	70
1A1A10L2	7-21	31	1A1A10Q37	7-21	43	1A1A10R48	7-21	69
1A1A10L3	7-21	32	1A1A10Q41	7-21	42	1A1A10R49	7-21	61
1A1A10L4	7-21	33	1A1A10Q42	7-21	42	1A1A10R50	7-21	71
1A1A10L5	7-21	33	1A1A10Q43	7-21	50	1A1A10R51	7-21	61
1A1A10L6	7-21	31	1A1A10Q45	7-21	51	1A1A10R52	7-21	72
1A1A10L7	7-21	31	1A1A10Q46	7-21	41	1A1A10R53	7-21	61
1A1A10L8	7-21	31	1A1A10Q47	7-21	50	1A1A10R54	7-21	72
1A1A10L14	7-21	34	1A1A10R1	7-21	52	1A1A10R55	7-21	73
1A1A10L15	7-21	34	1A1A10R2	7-21	53	1A1A10R56	7-21	74
1A1A10P1	7-21	35	1A1A10R3	7-21	54	1A1A10R57	7-21	69
1A1A10P2	7-21	35	1A1A10R4	7-21	55	1A1A10R58	7-21	75
1A1A10P3	7-21	35	1A1A10R5	7-21	56	1A1A10R59	7-21	61
1A1A10P4	7-21	36	1A1A10R6	7-21	57	1A1A10R60	7-21	76
1A1A10P5	7-21	37	1A1A10R7	7-21	56	1A1A10R61	7-21	77
1A1A10P6	7-21	37	1A1A10R8	7-21	57	1A1A10R62	7-21	78
1A1A10Q1	7-21	38	1A1A10R9	7-21	56	1A1A10R63	7-21	79
1A1A10Q2	7-21	39	1A1A10R10	7-21	57	1A1A10R64	7-21	80
1A1A10Q3	7-21	40	1A1A10R11	7-21	57	1A1A10R65	7-21	81
1A1A10Q4	7-21	40	1A1A10R13	7-21	56	1A1A10R66	7-21	80
1A1A10Q5	7-21	41	1A1A10R14	7-21	56	1A1A10R67	7-21	80
1A1A10Q6	7-21	39	1A1A10R15	7-21	56	1A1A10R68	7-21	82
1A1A10Q7	7-21	42	1A1A10R16	7-21	58	1A1A10R69	7-21	83
1A1A10Q8	7-21	43	1A1A10R17	7-21	59	1A1A10R70	7-21	84
1A1A10Q9	7-21	43	1A1A10R18	7-21	60	1A1A10R71	7-21	56
1A1A10Q10	7-21	43	1A1A10R19	7-21	61	1A1A10R72	7-21	85
1A1A10Q11	7-21	44	1A1A10R20	7-21	62	1A1A10R73	7-21	86

Reference Designation	Fig No.	Index No.	Reference Designation	Fig No.	Index No.	Reference Designation	Fig No.	Index No.
1A1A1OR74	7-21	87	1A1A1OR128	7-21	102	1A1A1OU17	7-21	132
1A1A1OR75	7-21	87	1A1A1OR129	7-21	87	1A1A1OU18	7-21	133
1A1A1OR76	7-21	88	1A1A1OR130	7-21	109	1A1A1OU19	7-21	134
1A1A1OR77	7-21	89	1A1A1OR131	7-21	61	1A1A1OU20	7-21	135
1A1A1OR78	7-21	61	1A1A1OR132	7-21	110	1A1A1OU21	7-21	136
1A1A1OR79	7-21	90	1A1A1OR133	7-21	110	1A1A1OU22	7-21	137
1A1A1OR80	7-21	91	1A1A1OR134	7-21	61	1A1A1OXU5	7-21	138
1A1A1OR81	7-21	76	1A1A1OR135	7-21	111			
1A1A1OR82	7-21	92	1A1A1OR136	7-21	112	1A1A11A1	7-4	1
1A1A1OR83	7-21	69	1A1A1OR137	7-21	99	1A1A11A1C1	7-23	1
1A1A1OR84	7-21	93	1A1A1OR138	7-21	113	1A1A11A1C2	7-23	2
1A1A1OR85	7-21	93	1A1A1OR139	7-21	87	1A1A11A1C3	7-23	1
1A1A1OR86	7-21	94	1A1A1OR140	7-21	61	1A1A11A1C4	7-23	1
1A1A1OR87	7-21	93	1A1A1OR141	7-21	99	1A1A11A1C5	7-23	3
1A1A1OR88	7-21	57	1A1A1OR158	7-21	64	1A1A11A1C6	7-23	1
1A1A1OR89	7-21	93	1A1A1OR159	7-21	60	1A1A11A1C7	7-23	1
1A1A1OR90	7-21	65	1A1A1OR160	7-21	57	1A1A11A1C8	7-23	1
1A1A1OR91	7-21	72	1A1A1OR161	7-21	114	1A1A11A1C9	7-23	1
1A1A1OR92	7-21	56	1A1A1OR162	7-21	56	1A1A11A1C10	7-23	1
1A1A1OR93	7-21	95	1A1A1OR163	7-21	64	1A1A11A1C12	7-23	4
1A1A1OR94	7-21	93	1A1A1OR164	7-21	114	1A1A11A1C13	7-23	4
1A1A1OR95	7-21	93	1A1A1OR165	7-21	64	1A1A11A1C16	7-23	1
1A1A1OR96	7-21	96	1A1A1OR166	7-21	67	1A1A11A1C17	7-23	5
1A1A1OR97	7-21	97	1A1A1OR167	7-21	67	1A1A11A1C18	7-23	5
1A1A1OR98	7-21	98	1A1A1OR169	7-21	94	1A1A11A1C19	7-23	1
1A1A1OR99	7-21	61	1A1A1OR170	7-21	114	1A1A11A1C20	7-23	6
1A1A1OR100	7-21	99	1A1A1OR171	7-21	57	1A1A11A1C21	7-23	1
1A1A1OR101	7-21	61	1A1A1OR172	7-21	64	1A1A11A1C22	7-23	1
1A1A1OR102	7-21	95	1A1A1OR173	7-21	115	1A1A11A1CR1	7-23	7
1A1A1OR103	7-21	93	1A1A1OR174	7-21	57	1A1A11A1CR2	7-23	7
1A1A1OR104	7-21	93	1A1A1OR175	7-21	116	1A1A11A1DS1	7-23	8
1A1A1OR105	7-21	96	1A1A1OTP1	7-21	117	1A1A11A1J1	7-23	9
1A1A1OR106	7-21	100	1A1A1OTP2	7-21	117	1A1A11A1J2	7-23	9
1A1A1OR107	7-21	56	1A1A1OTP3	7-21	117	1A1A11A1J3	7-23	10
1A1A1OR108	7-21	56	1A1A1OTP4	7-21	117	1A1A11A1J4	7-23	11
1A1A1OR109	7-21	101	1A1A1OU1	7-21	118	1A1A11A1J5	7-23	12
1A1A1OR110	7-21	101	1A1A1OU2	7-21	119	1A1A11A1J6	7-23	13
1A1A1OR111	7-21	56	1A1A1OU3	7-21	120	1A1A11A1JMP1	7-23	14
1A1A1OR112	7-21	102	1A1A1OU4	7-21	121	1A1A11A1L1	7-23	15
1A1A1OR113	7-21	95	1A1A1OU5	7-21	122	1A1A11A1L2	7-23	16
1A1A1OR114	7-21	103	1A1A1OU6	7-21	123	1A1A11A1L3	7-23	17
1A1A1OR115	7-21	104	1A1A1OU7	7-21	123	1A1A11A1P1	7-23	18
1A1A1OR117	7-21	95	1A1A1OU8	7-21	124	1A1A11A1Q1	7-23	19
1A1A1OR118	7-21	103	1A1A1OU9	7-21	125	1A1A11A1R2	7-23	20
1A1A1OR119	7-21	105	1A1A1OU10	7-21	125	1A1A11A1R3	7-23	21
1A1A1OR120	7-21	95	1A1A1OU11	7-21	126	1A1A11A1R4	7-23	22
1A1A1OR121	7-21	103	1A1A1OU12	7-21	127	1A1A11A1R5	7-23	20
1A1A1OR123	7-21	105	1A1A1OU13	7-21	128	1A1A11A1R8	7-23	23
1A1A1OR125	7-21	106	1A1A1OU14	7-21	129	1A1A11A1R9	7-23	24
1A1A1OR126	7-21	107	1A1A1OU15	7-21	130	1A1A11A1R10	7-23	25
1A1A1OR127	7-21	108	1A1A1OU16	7-21	131	1A1A11A1R11	7-23	26

Reference Designation	Fig No.	Index No.	Reference Designation	Fig No.	Index No.	Reference Designation	Fig No.	Index No.
1A1A11A1R12	7-23	26	1A1A11J1	7-4	3	1A1A12C52	7-25	2
1A1A11A1R13	7-23	26	1A1A11J2	7-4	4	1A1A12C53	7-25	2
1A1A11A1R14	7-23	26	1A1A11J3	7-4	3	1A1A12C54	7-25	2
1A1A11A1R15	7-23	26	1A1A11LS1	7-4	5	1A1A12C55	7-25	2
1A1A11A1R16	7-23	26	1A1A11P1	7-4	6	1A1A12C56	7-25	2
1A1A11A1R18	7-23	27	1A1A11P2	7-4	7	1A1A12C57	7-25	2
1A1A11A1R19	7-23	28	1A1A11P3	7-4	8	1A1A12C58	7-25	2
1A1A11A1R20	7-23	20	1A1A11P4	7-4	9	1A1A12C59	7-25	2
1A1A11A1R31	7-23	14	1A1A11R1	7-4	10	1A1A12C60	7-25	2
1A1A11A1R34	7-23	14	1A1A11S1	7-1	23	1A1A12CR2	7-25	8
1A1A11A1R36	7-23	14				1A1A12CR3	7-25	8
1A1A11A1R38	7-23	14	1A1A12	7-3	14	1A1A12CR4	7-25	8
1A1A11A1R40	7-23	14	1A1A12BT1	7-25	1	1A1A12CR5	7-25	8
1A1A11A1R42	7-23	14	1A1A12C1	7-25	2	1A1A12J1	7-25	9
1A1A11A1R44	7-23	14	1A1A12C4	7-25	3	1A1A12J2	7-25	10
1A1A11A1R45	7-23	29	1A1A12C7	7-25	4	1A1A12J3	7-25	10
1A1A11A1R46	7-23	30	1A1A12C8	7-25	2	1A1A12J4	7-25	11
1A1A11A1R47	7-23	21	1A1A12C9	7-25	2	1A1A12J5	7-25	12
1A1A11A1S1	7-23	31	1A1A12C10	7-25	5	1A1A12J6	7-25	13
1A1A11A1U1	7-23	32	1A1A12C12	7-25	6	1A1A12L1	7-25	14
1A1A11A1U2	7-23	33	1A1A12C13	7-25	2	1A1A12L2	7-25	14
1A1A11A1U3	7-23	34	1A1A12C14	7-25	7	1A1A12L3	7-25	14
1A1A11A1U4	7-23	35	1A1A12C15	7-25	2	1A1A12L4	7-25	15
1A1A11A1U5	7-23	36	1A1A12C16	7-25	6	1A1A12R2	7-25	16
1A1A11A1U7	7-23	37	1A1A12C17	7-25	2	1A1A12R3	7-25	17
1A1A11A1U8	7-23	38	1A1A12C19	7-25	2	1A1A12R4	7-25	18
1A1A11A1U9	7-23	39	1A1A12C20	7-25	2	1A1A12R5	7-25	19
1A1A11A1U10	7-23	40	1A1A12C23	7-25	3	1A1A12R7	7-25	20
1A1A11A1U12	7-23	41	1A1A12C24	7-25	2	1A1A12R8	7-25	20
1A1A11A1VR1	7-23	42	1A1A12C25	7-25	2	1A1A12R9	7-25	21
1A1A11A2	7-4	2	1A1A12C26	7-25	6	1A1A12R10	7-25	22
1A1A11A2DS1	7-24	1	1A1A12C27	7-25	6	1A1A12R11	7-25	22
1A1A11A2DS2	7-24	1	1A1A12C28	7-25	2	1A1A12R12	7-25	23
1A1A11A2DS3	7-24	2	1A1A12C29	7-25	2	1A1A12R13	7-25	24
1A1A11A2DS4	7-24	2	1A1A12C31	7-25	2	1A1A12R14	7-25	25
1A1A11A2A1	7-24	3	1A1A12C32	7-25	2	1A1A12R16	7-25	26
1A1A11A2A1C1	7-24	4	1A1A12C33	7-25	2	1A1A12R17	7-25	27
1A1A11A2A1C2	7-24	4	1A1A12C34	7-25	2	1A1A12R18	7-25	27
1A1A11A2A1C3	7-24	4	1A1A12C35	7-25	2	1A1A12R19	7-25	22
1A1A11A2A1C4	7-24	4	1A1A12C36	7-25	2	1A1A12R20	7-25	27
1A1A11A2A1C5	7-24	4	1A1A12C37	7-25	2	1A1A12R21	7-25	22
1A1A11A2A1P1	7-24	5	1A1A12C38	7-25	2	1A1A12R24	7-25	25
1A1A11A2A1P2	7-24	5	1A1A12C39	7-25	2	1A1A12R27	7-25	24
1A1A11A2A1U1	7-24	6	1A1A12C40	7-25	2	1A1A12R33	7-25	18
1A1A11A2A1U2	7-24	6	1A1A12C43	7-25	2	1A1A12R34	7-25	28
1A1A11A2A1U3	7-24	6	1A1A12C44	7-25	2	1A1A12R38	7-25	25
1A1A11A2A1U4	7-24	6	1A1A12C45	7-25	2	1A1A12R39	7-25	23
1A1A11A2A1U5	7-24	6	1A1A12C46	7-25	2	1A1A12R40	7-25	22
1A1A11A2A1	7-24	7	1A1A12C47	7-25	2	1A1A12R41	7-25	27
1A1A11A2	7-24	8	1A1A12C48	7-25	2	1A1A12R42	7-25	27
1A1A11A2	7-24	9	1A1A12C49	7-25	2	1A1A12R43	7-25	17

Reference Designation	Fig No.	Index No.	Reference Designation	Fig No.	Index No.	Reference Designation	Fig No.	Index No.
1A1A12R44	7-25	29	1A1A12U39	7-25	63	1A1A13CR26	7-26	5
1A1A12R47	7-25	24	1A1A12U41	7-25	44	1A1A13CR27	7-26	5
1A1A12R59	7-25	24	1A1A12U42	7-25	44	1A1A13CR28	7-26	5
1A1A12R60	7-25	18	1A1A12VR3	7-25	64	1A1A13J1	7-26	6
1A1A12R61	7-25	18	1A1A12VR4	7-25	65	1A1A13J2	7-26	7
1A1A12R62	7-25	18	1A1A12VR2	7-25	66	1A1A13J3	7-26	8
1A1A12R63	7-25	18	1A1A12XU1	7-25	67	1A1A13L1	7-26	9
1A1A12R64	7-25	18	1A1A12XU16	7-25	68	1A1A13L3	7-26	9
1A1A12R65	7-25	30	1A1A12XU17	7-25	68	1A1A13L4	7-26	9
1A1A12R66	7-25	29	1A1A12XU18	7-25	68	1A1A13L5	7-26	10
1A1A12R67	7-25	31	1A1A12Y1	7-25	69	1A1A13L6	7-26	9
1A1A12R68	7-25	32				1A1A13L7	7-26	11
1A1A12R69	7-25	33	1A1A13	7-5	7	1A1A13L8	7-26	9
1A1A12R70	7-25	18	1A1A13C1	7-26	1	1A1A13L10	7-26	9
1A1A12R71	7-25	26	1A1A13C2	7-26	1	1A1A13L11	7-26	9
1A1A12R72	7-25	34	1A1A13C3	7-26	1	1A1A13L12	7-26	9
1A1A12R73	7-25	34	1A1A13C4	7-26	2	1A1A13L13	7-26	9
1A1A12S1	7-25	35	1A1A13C5	7-26	1	1A1A13L14	7-26	10
1A1A12U1	7-25	36	1A1A13C6	7-26	1	1A1A13L15	7-26	9
1A1A12U2	7-25	37	1A1A13C7	7-26	1	1A1A13L16	7-26	10
1A1A12U3	7-25	38	1A1A13C8	7-26	1	1A1A13L18	7-26	10
1A1A12U4	7-25	39	1A1A13C9	7-26	1	1A1A13L19	7-26	10
1A1A12U5	7-25	40	1A1A13C10	7-26	1	1A1A13L20	7-26	10
1A1A12U6	7-25	41	1A1A13C11	7-26	1	1A1A13L21	7-26	9
1A1A12U7	7-25	42	1A1A13C12	7-26	2	1A1A13Q1	7-26	12
1A1A12U8	7-25	43	1A1A13C14	7-26	2	1A1A13Q3	7-26	12
1A1A12U9	7-25	44	1A1A13C16	7-26	3	1A1A13Q4	7-26	12
1A1A12U10	7-25	45	1A1A13C18	7-26	1	1A1A13Q5	7-26	12
1A1A12U11	7-25	46	1A1A13C19	7-26	1	1A1A13Q6	7-26	13
1A1A12U12	7-25	47	1A1A13C20	7-26	1	1A1A13Q7	7-26	12
1A1A12U13	7-25	48	1A1A13C23	7-26	2	1A1A13R1	7-26	14
1A1A12U14	7-25	49	1A1A13C25	7-26	3	1A1A13R2	7-26	15
1A1A12U15	7-25	50	1A1A13C27	7-26	3	1A1A13R3	7-26	16
1A1A12U16	7-25	81	1A1A13C29	7-26	3	1A1A13R4	7-26	17
1A1A12U17	7-25	82	1A1A13C31	7-26	3	1A1A13R5	7-26	18
1A1A12U18	7-25	83	1A1A13C33	7-26	1	1A1A13R6	7-26	19
1A1A12U19	7-25	51	1A1A13C34	7-26	1	1A1A13R7	7-26	19
1A1A12U20	7-25	51	1A1A13C35	7-26	3	1A1A13R8	7-26	20
1A1A12U21	7-25	52	1A1A13C37	7-26	2	1A1A13R9	7-26	21
1A1A12U22	7-25	53	1A1A13C39	7-26	2	1A1A13R10	7-26	22
1A1A12U23	7-25	54	1A1A13C41	7-26	2	1A1A13R11	7-26	16
1A1A12U24	7-25	55	1A1A13C43	7-26	4	1A1A13R12	7-26	16
1A1A12U26	7-25	56	1A1A13C45	7-26	2	1A1A13R13	7-26	23
1A1A12U28	7-25	50	1A1A13C49	7-26	2	1A1A13R14	7-26	24
1A1A12U29	7-25	56	1A1A13C51	7-26	2	1A1A13R15	7-26	19
1A1A12U30	7-25	57	1A1A13C55	7-26	2	1A1A13R16	7-26	20
1A1A12U31	7-25	58	1A1A13C61	7-26	1	1A1A13R18	7-26	25
1A1A12U32	7-25	59	1A1A13C62	7-26	1	1A1A13R20	7-26	26
1A1A12U33	7-25	60	1A1A13C63	7-26	4	1A1A13R21	7-26	27
1A1A12U34	7-25	52	1A1A13C64	7-26	2	1A1A13R22	7-26	16
1A1A12U35	7-25	61	1A1A13CR4	7-26	5	1A1A13U1	7-26	28
1A1A12U37	7-25	61	1A1A13CR5	7-26	5			
1A1A12U38	7-25	62						

Reference Designation	Fig No.	Index No.	Reference Designation	Fig No.	Index No.	Reference Designation	Fig No.	Index No.
1A1A13U2	7-26	29	1A1A14A1C32	7-28	13	1A1A14A1R11	7-28	51
1A1A13U3	7-26	30	1A1A14A1C33	7-28	13	1A1A14A1R12	7-28	51
1A1A13U4	7-26	31	1A1A14A1C34	7-28	8	1A1A14A1R13	7-28	52
1A1A13U5	7-26	32	1A1A14A1C35	7-28	21	1A1A14A1R14	7-28	52
1A1A13U6	7-26	33	1A1A14A1C36	7-28	8	1A1A14A1R15	7-28	53
1A1A13U7	7-26	34	1A1A14A1C37	7-28	22	1A1A14A1R16	7-28	53
1A1A13U8	7-26	35	1A1A14A1C38	7-28	23	1A1A14A1R17	7-28	54
1A1A13U9	7-26	30	1A1A14A1C39	7-28	24	1A1A14A1R18	7-28	54
1A1A13U10	7-26	33	1A1A14A1C40	7-28	25	1A1A14A1R19	7-28	55
1A1A13U11	7-26	33	1A1A14A1CR1	7-28	26	1A1A14A1R20	7-28	45
1A1A13U12	7-26	35	1A1A14A1CR2	7-28	27	1A1A14A1R21	7-28	56
1A1A13U13	7-26	36	1A1A14A1CR3	7-28	27	1A1A14A1R22	7-28	57
1A1A13U14	7-26	37	1A1A14A1CR4	7-28	27	1A1A14A1R23	7-28	58
1A1A13U15	7-26	38	1A1A14A1CR5	7-28	27	1A1A14A1R24	7-28	59
1A1A13U16	7-26	39	1A1A14A1CR8	7-28	28	1A1A14A1R25	7-28	60
1A1A13U17	7-26	40	1A1A14A1CR9	7-28	28	1A1A14A1R26	7-28	61
			1A1A14A1CR10	7-28	28	1A1A14A1R27	7-28	62
1A1A14	7-5	8	1A1A14A1CR11	7-28	28	1A1A14A1R28	7-28	63
1A1A14A1	7-27	4	1A1A14A1CR12	7-28	29	1A1A14A1R29	7-28	64
1A1A14A1AR1	7-28	4	1A1A14A1CR13	7-28	30	1A1A14A1R30	7-28	55
1A1A14A1C1	7-28	5	1A1A14A1CR16	7-28	28	1A1A14A1R31	7-28	58
1A1A14A1C2	7-28	6	1A1A14A1CR17	7-28	28	1A1A14A1R32	7-28	65
1A1A14A1C3	7-28	7	1A1A14A1CR22	7-28	27	1A1A14A1R33	7-28	60
1A1A14A1C4	7-28	8	1A1A14A1CR23	7-28	28	1A1A14A1R34	7-28	66
1A1A14A1C5	7-28	8	1A1A14A1CR24	7-28	27	1A1A14A1R35	7-28	67
1A1A14A1C6	7-28	8	1A1A14A1L1	7-28	31	1A1A14A1R36	7-28	50
1A1A14A1C7	7-28	9	1A1A14A1L2	7-28	32	1A1A14A1R37	7-28	68
1A1A14A1C8	7-28	8	1A1A14A1L3	7-28	33	1A1A14A1R38	7-28	69
1A1A14A1C9	7-28	10	1A1A14A1L4	7-28	34	1A1A14A1R39	7-28	51
1A1A14A1C10	7-28	11	1A1A14A1Q1	7-28	35	1A1A14A1R40	7-28	68
1A1A14A1C11	7-28	12	1A1A14A1Q3	7-28	36	1A1A14A1R41	7-28	70
1A1A14A1C12	7-28	10	1A1A14A1Q4	7-28	36	1A1A14A1R42	7-28	71
1A1A14A1C13	7-28	13	1A1A14A1Q6	7-28	37	1A1A14A1R43	7-28	72
1A1A14A1C14	7-28	14	1A1A14A1Q7	7-28	37	1A1A14A1R44	7-28	73
1A1A14A1C15	7-28	15	1A1A14A1Q8	7-28	38	1A1A14A1R45	7-28	74
1A1A14A1C16	7-28	16	1A1A14A1Q9	7-28	39	1A1A14A1R46	7-28	75
1A1A14A1C17	7-28	10	1A1A14A1Q10	7-28	40	1A1A14A1R47	7-28	76
1A1A14A1C18	7-28	10	1A1A14A1Q11	7-28	41	1A1A14A1R48	7-28	77
1A1A14A1C19	7-28	16	1A1A14A1Q12	7-28	42	1A1A14A1R49	7-28	78
1A1A14A1C20	7-28	16	1A1A14A1Q13	7-28	35	1A1A14A1R50	7-28	67
1A1A14A1C21	7-28	17	1A1A14A1Q14	7-28	42	1A1A14A1R51	7-28	60
1A1A14A1C22	7-28	13	1A1A14A1R1	7-28	43	1A1A14A1R52	7-28	61
1A1A14A1C23	7-28	15	1A1A14A1R2	7-28	44	1A1A14A1R53	7-28	61
1A1A14A1C24	7-28	11	1A1A14A1R3	7-28	45	1A1A14A1R54	7-28	79
1A1A14A1C25	7-28	18	1A1A14A1R4	7-28	46	1A1A14A1R55	7-28	57
1A1A14A1C26	7-28	19	1A1A14A1R5	7-28	47	1A1A14A1R56	7-28	80
1A1A14A1C27	7-28	20	1A1A14A1R6	7-28	48	1A1A14A1R57	7-28	81
1A1A14A1C28	7-28	20	1A1A14A1R7	7-28	49	1A1A14A1R58	7-28	57
1A1A14A1C29	7-28	16	1A1A14A1R8	7-28	49	1A1A14A1R59	7-28	57
1A1A14A1C30	7-28	16	1A1A14A1R9	7-28	50	1A1A14A1R60	7-28	70
1A1A14A1C31	7-28	11	1A1A14A1R10	7-28	50	1A1A14A1R61	7-28	82

Reference Designation	Fig No.	Index No.	Reference Designation	Fig No.	Index No.	Reference Designation	Fig No.	Index No.
1A1A14A1R62	7-28	51	1A1A15P15	7-29	25	1A1A18	7-8	
1A1A14A1R63	7-28	83	1A1A15P16	7-29	26	1A1A18A1	7-8	1
1A1A14A1R64	7-28	70	1A1A15P4A	7-29	27	1A1A18A1AR1	7-32	1
1A1A14A1R65	7-28	60	1A1A15P5A	7-29	28	1A1A18A1AR2	7-32	2
1A1A14A1R66	7-28	84	1A1A15P14A	7-29	28	1A1A18A1AR3	7-32	2
1A1A14A1R67	7-28	85	1A1A15P4B	7-29	29	1A1A18A1AR4	7-32	2
1A1A14A1R68	7-28	70	1A1A15P5B	7-29	30	1A1A18A1AR5	7-32	2
1A1A14A1R69	7-28	86	1A1A15P14B	7-29	31	1A1A18A1AR6	7-32	2
1A1A14A1R70	7-28	68	1A1A15P14C	7-29	32	1A1A18A1AR7	7-32	2
1A1A14A1R71	7-28	50	1A1A15R1	7-29	33	1A1A18A1AR8	7-32	2
1A1A14A1R72	7-28	87	1A1A15R2	7-29	34	1A1A18A1C1	7-32	3
1A1A14A1R73	7-28	85	1A1A15TP1	7-29	35	1A1A18A1C2	7-32	4
1A1A14A1T1	7-28	88	1A1A15TP2	7-29	35	1A1A18A1C3	7-32	5
1A1A14A1T2	7-28	89	1A1A15TP3	7-29	36	1A1A18A1C4	7-32	4
1A1A14A1T3	7-28	90	1A1A15TP4	7-29	37	1A1A18A1C5	7-32	5
1A1A14A1T4	7-28	91	1A1A15TP5	7-29	38	1A1A18A1C6	7-32	4
1A1A14A1U1	7-28	92				1A1A18A1C7	7-32	5
1A1A14A1U2	7-28	93	1A1A16	7-6	5	1A1A18A1C8	7-32	5
1A1A14A1VR1	7-28	94	1A1A16CR1	7-30	1	1A1A18A1C9	7-32	5
1A1A14A1VR2	7-28	95	1A1A16C1	7-30	2	1A1A18A1C10	7-32	6
1A1A14A1VR3	7-28	96	1A1A16C2	7-30	2	1A1A18A1C11	7-32	5
1A1A14A2	7-27	6	1A1A16C3	7-30	2	1A1A18A1C12	7-32	5
			1A1A16C4	7-30	2	1A1A18A1C13	7-32	7
1A1A15	7-5	9	1A1A16C5	7-30	2	1A1A18A1C14	7-32	8
1A1A15C1	7-29	1	1A1A16C6	7-30	2	1A1A18A1C15	7-32	8
1A1A15CR1	7-29	2	1A1A16J1	7-30	3	1A1A18A1C16	7-32	5
1A1A15DS1	7-29	4	1A1A16J2	7-30	4	1A1A18A1C17	7-32	5
1A1A15DS2	7-29	4	1A1A16K1	7-30	5	1A1A18A1C18	7-32	5
1A1A15J1	7-29	5	1A1A16R1	7-30	6	1A1A18A1C19	7-32	5
1A1A15J2	7-29	6	1A1A16R2	7-30	7	1A1A18A1C20	7-32	5
1A1A15J3	7-29	7	1A1A16R3	7-30	8	1A1A18A1C21	7-32	5
1A1A15J4	7-29	8	1A1A16R4	7-30	9	1A1A18A1C22	7-32	9
1A1A15J5	7-29	9	1A1A16R5	7-30	6	1A1A18A1C23	7-32	10
1A1A15J6	7-29	10	1A1A16R6	7-30	7	1A1A18A1C24	7-32	11
1A1A15J7	7-29	10	1A1A16R7	7-30	9	1A1A18A1C25	7-32	12
1A1A15J8	7-29	11	1A1A16R8	7-30	9	1A1A18A1C26	7-32	5
1A1A15J10	7-29	6	1A1A16R9	7-30	10	1A1A18A1C27	7-32	12
1A1A15J11	7-29	6	1A1A16S1	7-30	11	1A1A18A1C28	7-32	13
1A1A15J12	7-29	12	1A1A16S2	7-30	11	1A1A18A1C29	7-32	5
1A1A15L1	7-29	13	1A1A16T1	7-30	12	1A1A18A1C30	7-32	13
1A1A15P1	7-29	14	1A1A16T2	7-30	12	1A1A18A1C31	7-32	12
1A1A15P2	7-29	15	1A1A16T3	7-30	12	1A1A18A1C32	7-32	5
1A1A15P3	7-29	16	1A1A16T4	7-30	12	1A1A18A1C33	7-32	14
1A1A15P6	7-29	17	1A1A16TB1	7-30	13	1A1A18A1C34	7-32	5
1A1A15P7	7-29	18				1A1A18A1C35	7-32	5
1A1A15P8	7-29	19	1A1A17	7-6	6	1A1A18A1C36	7-32	5
1A1A15P9	7-29	20	1A1A17E1	7-31	2	1A1A18A1C37	7-32	5
1A1A15P10	7-29	21	1A1A17J1	7-31	3	1A1A18A1C38	7-32	5
1A1A15P11	7-29	22	1A1A17J2	7-31	4	1A1A18A1C39	7-32	5
1A1A15P12	7-29	23	1A1A17W1	7-31	5	1A1A18A1C40	7-32	15
1A1A15P13	7-29	24				1A1A18A1C41	7-32	5



Reference Designation	Fig No.	Index No.	Reference Designation	Fig No.	Index No.	Reference Designation	Fig No.	Index No.
1A1A18A1C42	7-32	16	1A1A18A1C98	7-32	30	1A1A18A1R30	7-32	63
1A1A18A1C43	7-32	5	1A1A18A1C99	7-32	4	1A1A18A1R31	7-32	64
1A1A18A1C44	7-32	17	1A1A18A1CR1	7-32	31	1A1A18A1R32	7-32	65
1A1A18A1C45	7-32	18	1A1A18A1CR3	7-32	32	1A1A18A1R33	7-32	66
1A1A18A1C46	7-32	19	1A1A18A1CR4	7-32	33	1A1A18A1R34	7-32	67
1A1A18A1C47	7-32	5	1A1A18A1CR5	7-32	33	1A1A18A1R35	7-32	49
1A1A18A1C48	7-32	20	1A1A18A1CR6	7-32	33	1A1A18A1R36	7-32	49
1A1A18A1C49	7-32	20	1A1A18A1CR7	7-32	33	1A1A18A1R37	7-32	49
1A1A18A1C50	7-32	21	1A1A18A1CR8	7-32	33	1A1A18A1R38	7-32	68
1A1A18A1C51	7-32	5	1A1A18A1CR9	7-32	33	1A1A18A1R39	7-32	69
1A1A18A1C52	7-32	22	1A1A18A1CR10	7-32	33	1A1A18A1R40	7-32	70
1A1A18A1C53	7-32	23	1A1A18A1CR11	7-32	33	1A1A18A1R41	7-32	52
1A1A18A1C54	7-32	24	1A1A18A1JMP1	7-32	34	1A1A18A1R42	7-32	71
1A1A18A1C55	7-32	5	1A1A18A1JMP2	7-32	34	1A1A18A1R43	7-32	72
1A1A18A1C56	7-32	5	1A1A18A1JMP3	7-32	34	1A1A18A1R44	7-32	73
1A1A18A1C57	7-32	16	1A1A18A1JMP4	7-32	34	1A1A18A1R45	7-32	52
1A1A18A1C58	7-32	5	1A1A18A1J1	7-32	35	1A1A18A1R46	7-32	74
1A1A18A1C59	7-32	16	1A1A18A1J2	7-32	36	1A1A18A1R47	7-32	75
1A1A18A1C60	7-32	5	1A1A18A1J3	7-32	37	1A1A18A1R48	7-32	76
1A1A18A1C61	7-32	5	1A1A18A1L1	7-32	38	1A1A18A1R49	7-32	52
1A1A18A1C62	7-32	25	1A1A18A1L2	7-32	38	1A1A18A1R50	7-32	77
1A1A18A1C63	7-32	26	1A1A18A1L3	7-32	39	1A1A18A1R51	7-32	43
1A1A18A1C64	7-32	26	1A1A18A1Q2	7-32	40	1A1A18A1R52	7-32	43
1A1A18A1C65	7-32	26	1A1A18A1R1	7-32	41	1A1A18A1R53	7-32	78
1A1A18A1C66	7-32	26	1A1A18A1R2	7-32	42	1A1A18A1R54	7-32	45
1A1A18A1C67	7-32	26	1A1A18A1R3	7-32	43	1A1A18A1R55	7-32	45
1A1A18A1C68	7-32	26	1A1A18A1R4	7-32	44	1A1A18A1R56	7-32	67
1A1A18A1C69	7-32	16	1A1A18A1R5	7-32	43	1A1A18A1R57	7-32	45
1A1A18A1C70	7-32	26	1A1A18A1R7	7-32	45	1A1A18A1R58	7-32	49
1A1A18A1C71	7-32	4	1A1A18A1R8	7-32	46	1A1A18A1R59	7-32	66
1A1A18A1C72	7-32	26	1A1A18A1R9	7-32	45	1A1A18A1R60	7-32	66
1A1A18A1C73	7-32	14	1A1A18A1R10	7-32	47	1A1A18A1R61	7-32	66
1A1A18A1C74	7-32	5	1A1A18A1R11	7-32	48	1A1A18A1R62	7-32	79
1A1A18A1C75	7-32	5	1A1A18A1R12	7-32	41	1A1A18A1R63	7-32	79
1A1A18A1C76	7-32	5	1A1A18A1R13	7-32	45	1A1A18A1R64	7-32	79
1A1A18A1C77	7-32	5	1A1A18A1R14	7-32	49	1A1A18A1R65	7-32	66
1A1A18A1C78	7-32	5	1A1A18A1R15	7-32	49	1A1A18A1R66	7-32	66
1A1A18A1C80	7-32	5	1A1A18A1R16	7-32	50	1A1A18A1R67	7-32	66
1A1A18A1C81	7-32	5	1A1A18A1R17	7-32	51	1A1A18A1R69	7-32	80
1A1A18A1C82	7-32	5	1A1A18A1R18	7-32	52	1A1A18A1R70	7-32	43
1A1A18A1C83	7-32	27	1A1A18A1R19	7-32	50	1A1A18A1R71	7-32	49
1A1A18A1C84	7-32	5	1A1A18A1R20	7-32	53	1A1A18A1R72	7-32	81
1A1A18A1C85	7-32	5	1A1A18A1R21	7-32	54	1A1A18A1R73	7-32	54
1A1A18A1C86	7-32	5	1A1A18A1R22	7-32	55	1A1A18A1R74	7-32	82
1A1A18A1C87	7-32	28	1A1A18A1R23	7-32	56	1A1A18A1R78	7-32	49
1A1A18A1C88	7-32	4	1A1A18A1R24	7-32	57	1A1A18A1R79	7-32	57
1A1A18A1C89	7-32	14	1A1A18A1R25	7-32	58	1A1A18A1R80	7-32	79
1A1A18A1C90	7-32	14	1A1A18A1R26	7-32	59	1A1A18A1R81	7-32	83
1A1A18A1C91	7-32	29	1A1A18A1R27	7-32	60	1A1A18A1R82	7-32	84
1A1A18A1C96	7-32	8	1A1A18A1R28	7-32	61	1A1A18A1R83	7-32	67
1A1A18A1C97	7-32	5	1A1A18A1R29	7-32	62	1A1A18A1R84	7-32	85

Reference Designation	Fig No.	Index No.	Reference Designation	Fig No.	Index No.	Reference Designation	Fig No.	Index No.
1A1A18A1R85	7-32	86	1A1A18A2CR2	7-33	2	1A2A1C3	7-34	6
1A1A18A1R86	7-32	87	1A1A18A2CR3	7-33	2	1A2A1C5	7-34	6
1A1A18A1R87	7-32	45	1A1A18A2CR4	7-33	2	1A2A1C7	7-34	6
1A1A18A1R88	7-32	45	1A1A18A2CR5	7-33	2	1A2A1C8	7-34	6
1A1A18A1R89	7-32	49	1A1A18A2CR6	7-33	2	1A2A1C4	7-34	7
1A1A18A1R90	7-32	49	1A1A18A2CR7	7-33	2	1A2A1C6	7-34	8
1A1A18A1R91	7-32	49	1A1A18A2CR8	7-33	2	1A2A1C10	7-34	9
1A1A18A1R92	7-32	49	1A1A18A2CR9	7-33	2	1A2A1CR1	7-34	10
1A1A18A1R95	7-32	41	1A1A18A2CR10	7-33	2	1A2A1CR5	7-34	10
1A1A18A1R96	7-32	48	1A1A18A2CR11	7-33	2	1A2A1CR14	7-34	10
1A1A18A1R97	7-32	88	1A1A18A2CR12	7-33	2	1A2A1CR16	7-34	10
1A1A18A1R98	7-32	51	1A1A18A2FL1	7-33	3	1A2A1CR19	7-34	10
1A1A18A1R99	7-32	89	1A1A18A2FL2	7-33	4	1A2A1CR20	7-34	10
1A1A18A1R100	7-32	49	1A1A18A2FL3	7-33	5	1A2A1CR23	7-34	10
1A1A18A1TP1	7-32	90	1A1A18A2J1	7-33	6	1A2A1CR24	7-34	10
1A1A18A1TP2	7-32	91	1A1A18A2R1	7-33	7	1A2A1CR26	7-34	10
1A1A18A1TP3	7-32	92	1A1A18A2R2	7-33	8	1A2A1CR27	7-34	10
1A1A18A1U1	7-32	93	1A1A18A2R3	7-33	9	1A2A1CR28	7-34	10
1A1A18A1U2	7-32	94	1A1A18A2R4	7-33	10	1A2A1CR2	7-34	11
1A1A18A1U3	7-32	95	1A1A18A2R5	7-33	11	1A2A1CR3	7-34	12
1A1A18A1U4	7-32	96	1A1A18A2R6	7-33	7	1A2A1CR4	7-34	12
1A1A18A1U5	7-32	97	1A1A18A2R7	7-33	8	1A2A1CR6	7-34	12
1A1A18A1U6	7-32	94	1A1A18A2R8	7-33	9	1A2A1CR7	7-34	12
1A1A18A1U7	7-32	98	1A1A18A2R9	7-33	10	1A2A1CR9	7-34	12
1A1A18A1U8	7-32	99	1A1A18A2R10	7-33	12	1A2A1CR10	7-34	12
1A1A18A1U9	7-32	100	1A1A18A2R11	7-33	7	1A2A1CR11	7-34	12
1A1A18A1U10	7-32	101	1A1A18A2R12	7-33	8	1A2A1CR12	7-34	12
1A1A18A1U11	7-32	102	1A1A18A2R13	7-33	9	1A2A1CR15	7-34	12
1A1A18A1U12	7-32	103	1A1A18A2R14	7-33	10	1A2A1CR31	7-34	12
1A1A18A1U13	7-32	104	1A1A18A2R15	7-33	12	1A2A1CR8	7-34	13
1A1A18A1U14	7-32	105	1A1A18A2S1	7-33	13	1A2A1CR13	7-34	14
1A1A18A1U15	7-32	106	1A1A18A2S2	7-33	14	1A2A1CR25	7-34	15
1A1A18A1U16	7-32	107				1A2A1DS2	7-34	15
1A1A18A1U17	7-32	107	1A1A20	7-6	7	1A2A1DS3	7-34	15
1A1A18A1U18	7-32	107	1A1A20F1	7-6	16	1A2A1CR29	7-34	16
1A1A18A1U19	7-32	108	1A1A20J6	7-6	17	1A2A1CR30	7-34	17
1A1A18A1U20	7-32	109	1A1A20J7	7-6	18	1A2A1J1	7-34	18
1A1A18A1U21	7-32	110	1A1A20X1	7-6	19	1A2A1J2	7-34	19
1A1A18A1VR1	7-32	111				1A2A1J3	7-34	20
UA1A18A1VR2	7-32	112	1A1W10	7-10	1	1A2A1J4	7-34	21
1A1A18A1XU5	7-32	113	1A1W11	7-10	2	1A2A1L1	7-34	22
1A1A18A1Y1	7-32	114	1A1W12	7-10	3	1A2A1Q1	7-34	23
			1A1W13	7-10	4	1A2A1Q2	7-34	23
1A1A18A2	7-8	2	1A1W14	7-10	5	1A2A1Q4	7-34	23
1A1A18A2C1	7-33	1	1A1W15	7-10	6	1A2A1Q12	7-34	23
1A1A18A2C2	7-33	1				1A2A1Q16	7-34	23
1A1A18A2C5	7-33	1	1A2	7-2		1A2A1Q3	7-34	24
1A1A18A2C6	7-33	1	1A2A1	7-2	6	1A2A1Q6	7-34	24
1A1A18A2C9	7-33	1	1A2A1AR1	7-34	1	1A2A1Q8	7-34	24
1A1A18A2C10	7-33	1	1A2A1C1	7-34	2	1A2A1Q13	7-34	24
1A1A18A2CR1	7-33	2	1A2A1C2	7-34	5	1A2A1Q15	7-34	24

Reference Designation	Fig No.	Index No.	Reference Designation	Fig No.	Index No.	Reference Designation	Fig No.	Index No.
1A2A1Q17	7-34	24	1A2A1R40	7-34	54	1A2A2A1Q4	7-36	22
1A2A1Q10	7-34	25	1A2A1R41	7-34	55	1A2A2A1Q5	7-36	21
1A2A1Q5	7-34	26	1A2A1R42	7-34	56	1A2A2A1Q6	7-36	22
1A2A1Q7	7-34	26	1A2A1R43	7-34	57	1A2A2A1Q7	7-36	20
1A2A1Q9	7-34	26	1A2A1R44	7-34	57	1A2A2A1Q8	7-36	21
1A2A1Q11	7-34	26	1A2A1R47	7-34	58	1A2A2A1Q9	7-36	23
1A2A1Q14	7-34	26	1A2A1R48	7-34	58	1A2A2A1Q10	7-36	22
1A2A1R2	7-34	27	1A2A1R51	7-34	59	1A2A2A1Q11	7-36	21
1A2A1R3	7-34	28	1A2A1R52	7-34	60	1A2A2A1Q12	7-36	22
1A2A1R4	7-34	29	1A2A1R53	7-34	61	1A2A2A1R1	7-36	24
1A2A1R5	7-34	30	1A2A1R58	7-34	62	1A2A2A1R2	7-36	25
1A2A1R6	7-34	31	1A2A1TB1	7-34	63	1A2A2A1R3	7-36	26
1A2A1R34	7-34	31				1A2A2A1R4	7-36	27
1A2A1R7	7-34	32	1A2A2	7-2	7	1A2A2A1R5	7-36	25
1A2A1R8	7-34	33	1A2A2A1C1	7-36	1	1A2A2A1R6	7-36	28
1A2A1R9	7-34	34	1A2A2A1C2	7-36	2	1A2A2A1R7	7-36	29
1A2A1R10	7-34	35	1A2A2A1C3	7-36	2	1A2A2A1R7	7-36	30
1A2A1R11	7-34	35	1A2A2A1C4	7-36	3	1A2A2A1R8	7-36	31
1A2A1R12	7-34	36	1A2A2A1C5	7-36	2	1A2A2A1R9	7-36	32
1A2A1R16	7-34	36	1A2A2A1C6	7-36	4	1A2A2A1R10	7-36	33
1A2A1R18	7-34	36	1A2A2A1C7	7-36	5	1A2A2A1R11	7-36	34
1A2A1R20	7-34	36	1A2A2A1C8	7-36	6	1A2A2A1R12	7-36	35
1A2A1R29	7-34	36	1A2A2A1C9	7-36	7	1A2A2A1R13	7-36	36
1A2A1R30	7-34	36	1A2A2A1C11	7-36	8	1A2A2A1R14	7-36	36
1A2A1R54	7-34	36	1A2A2A1C12	7-36	9	1A2A2A1R15	7-36	37
1A2A1R13	7-34	37	1A2A2A1C13	7-36	2	1A2A2A1R16	7-36	31
1A2A1R23	7-34	37	1A2A2A1C14	7-36	2	1A2A2A1R17	7-36	38
1A2A1R14	7-34	38	1A2A2A1C15	7-36	10	1A2A2A1R18	7-36	37
1A2A1R15	7-34	39	1A2A2A1C16	7-36	11	1A2A2A1R19	7-36	39
1A2A1R17	7-34	40	1A2A2A1C17	7-36	2	1A2A2A1R20	7-36	40
1A2A1R19	7-34	41	1A2A2A1C18	7-36	12	1A2A2A1R21	7-36	41
1A2A1R22	7-34	41	1A2A2A1C19	7-36	6	1A2A2A1R22	7-36	31
1A2A1R21	7-34	42	1A2A2A1C20	7-36	13	1A2A2A1R23	7-36	37
1A2A1R55	7-34	42	1A2A2A1CR1	7-36	14	1A2A2A1R24	7-36	42
1A2A1R24	7-34	43	1A2A2A1CR2	7-36	15	1A2A2A1R25	7-36	34
1A2A1R45	7-34	43	1A2A2A1CR3	7-36	16	1A2A2A1R26	7-36	43
1A2A1R46	7-34	43	1A2A2A1CR4	7-36	17	1A2A2A1R27	7-36	44
1A2A1R49	7-34	43	1A2A2A1CR5	7-36	17	1A2A2A1R28	7-36	45
1A2A1R50	7-34	43	1A2A2A1CR6	7-36	17	1A2A2A1R29	7-36	29
1A2A1R56	7-34	43	1A2A2A1CR7	7-36	17	1A2A2A1R30	7-36	46
1A2A1R25	7-34	44	1A2A2A1CR8	7-36	17	1A2A2A1R31	7-36	47
1A2A1R57	7-34	44	1A2A2A1CR9	7-36	15	1A2A2A1R32	7-36	48
1A2A1R26	7-34	45	1A2A2A1CR10	7-36	15	1A2A2A1R33	7-36	49
1A2A1R28	7-34	46	1A2A2A1CR11	7-36	15	1A2A2A1R34	7-36	50
1A2A1R31	7-34	47	1A2A2A1CR13	7-36	15	1A2A2A1R35	7-36	51
1A2A1R32	7-34	48	1A2A2A1CR14	7-36	15	1A2A2A1R36	7-36	52
1A2A1R33	7-34	49	1A2A2A1J1	7-36	18	1A2A2A1R36	7-36	53
1A2A1R35	7-34	50	1A2A2A1J2	7-36	19	1A2A2A1R37	7-36	54
1A2A1R36	7-34	51	1A2A2A1Q1	7-36	20	1A2A2A1R38	7-36	55
1A2A1R37	7-34	52	1A2A2A1Q2	7-36	21	1A2A2A1R39	7-36	56
1A2A1R38	7-34	53	1A2A2A1Q3	7-36	22	1A2A2A1R40	7-36	57

Reference Designation	Fig No.	Index No.	Reference Designation	Fig No.	Index No.	Reference Designation	Fig No.	Index No.
1A2A2A1R41	7-36	58	1A2A2C4	7-35	5	1A2CB3	7-2	13
1A2A2A1R42	7-36	38	1A2A2C5	7-35	5	1A2CR1	7-2	14
1A2A2A1R44	7-36	59	1A2A2C6	7-35	6	1A2CR2	7-2	15
1A2A2A1R45	7-36	26	1A2A2C7	7-35	6	1A2CR3	7-2	15
1A2A2A1R46	7-36	26	1A2A2CR1	7-35	7	1A2CR4	7-2	14
1A2A2A1R47	7-36	60	1A2A2CR2	7-35	8	1A2J1	7-2	16
1A2A2A1R48	7-36	61	1A2A2CR3	7-35	8	1A2JMP1	7-2	17
1A2A2A1R49	7-36	62	1A2A2L1	7-35	9	1A2K1	7-2	18
1A2A2A1R50	7-36	39	1A2A2P1	7-35	10	1A2K2	7-2	19
1A2A2A1R51	7-36	52	1A2A2P2	7-35	11	1A2K3	7-2	20
1A2A2A1R52	7-36	63	1A2A2P3	7-35	11	1A2R1	7-2	21
1A2A2A1R53	7-36	64	1A2A2Q1	7-35	12	1A2R2	7-2	22
1A2A2A1R54	7-36	46	1A2A2Q2	7-35	12	1A2R3	7-2	23
1A2A2A1R55	7-36	65	1A2A2Q3	7-35	13	1A2RT1	7-2	24
1A2A2A1T1	7-36	66	1A2A2R4	7-35	14	1A2S1	7-2	25
1A2A2A1T2	7-36	67	1A2A2R5	7-35	15	1A2T1	7-2	26
1A2A2A1TB1	7-36	68	1A2A2RT1	7-35	16	1A2T2	7-2	27
1A2A2A1U1	7-36	69	1A2B1	7-2	9	1A2VR1	7-2	28
1A2A2C1	7-35	3	1A2C1	7-2	10	1A2VR2	7-2	28
1A2A2C2	7-35	3	1A2C2	7-2	11			
1A2A2C3	7-35	4	1A2CB1	7-2	12			

**CHAPTER 8**  
**FOLDOUT DRAWINGS**

**LIST OF 100 WATT TRANSCEIVER FOLDOUT DRAWINGS**

- FO-1 Family Tree 100 Watt Transceiver
- FO-2 Transceiver Assy, A1, Interconnection Diagram
- FO-3 Exciter PWB Assy, A1A1
- FO-4 IF Filter PWB Assy, A1A2
- FO-5 First Converter PWB Assy, A1A3
- FO-6 Power Amplifier PWB Assy, A1A4A1
- FO-7 Low Pass Filter PWB Assy, A1A5
- FO-8 AGC/TGC PWB Assy, A1A6
- FO-9 Receiver PWB Assy, A1A7
- FO-10 REF/BFO PWB Assy, A1A9
- FO-11 Synthesizer PWB Assy, A1A10
- FO-12 Front Panel Assy, A1A11
- FO-13 Front Panel PWB Assy, A1A11A1
- FO-14 Display Assy, A1A11A2
- FO-15 Transceiver Control PWB Assy, A1A12
- FO-16 LPA/Coupler Interface PWB Assy, A1A13
- FO-17 Multivoltage Supply PWB Assy, A1A14A1
- FO-18 Interconnect PWB Assy, A1A15
- FO-19 Audio Interface PWB Assy, A1A16
- FO-20 Coupler Connector PWB Assy, A1A17
- FO-21 AFSK Module Assy, A1A18

**T.O. 31R2-2URC-83**

FO-22 Power Supply Assy, A2, Interconnection Diagram

FO-23 Power Supply Protection and Control PWB Assy, A2A1

FO-24 13.6 V Power Supply Assy, A2A2

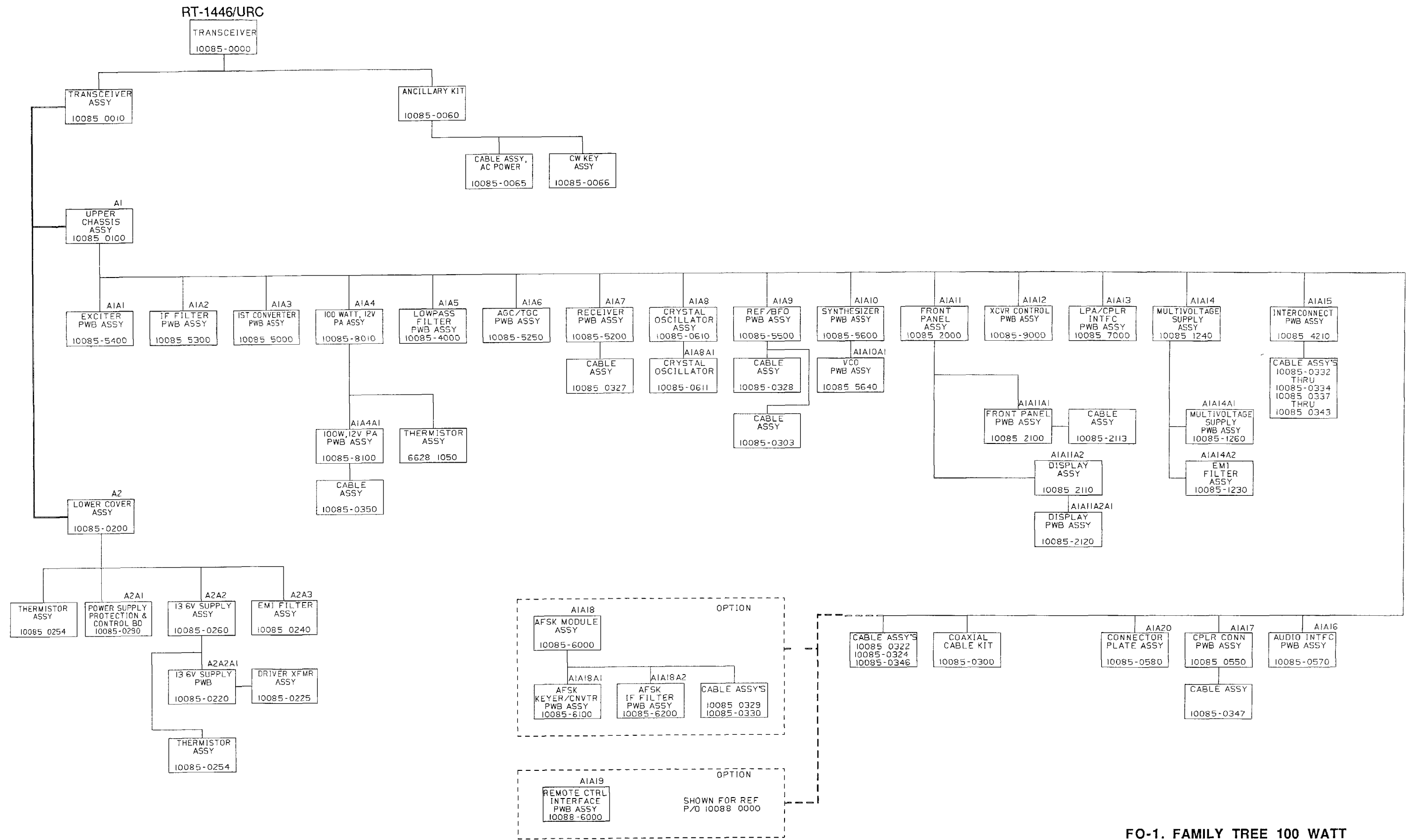

FO-1. FAMILY TREE 100 WATT TRANSCEIVER





NOTE: UNLESS OTHERWISE SPECIFIED:

- 1 PARTIAL REFERENCE DESIGNATIONS ARE SHOWN FOR DETAIL PARTS. PREFIX THESE WITH UNIT NO. AND/OR ASSEMBLY DESIGNATIONS SHOWN ON DRAWING TO OBTAIN COMPLETE DESIGNATIONS.
- 2 ALL RESISTOR VALUES ARE IN OHMS, 1/4W. ±5%
- 3 ALL CAPACITOR VALUES ARE IN MICROFARADS (UF)
- 4 ALL INDUCTANCE VALUES ARE IN MILLIHENRIES (MH)
- 5 VENDOR PART NO. CALLOUTS ARE FOR REFERENCE ONLY. COMPONENTS ARE SUPPLIED PER PART NO. IN PARTS LIST
- 6 DC RESISTANCES OF INDUCTIVE ELEMENTS (CHOKES, COILS, MOTOR WINDINGS, ETC.) ARE LESS THAN 1 OHM
- 7 PANEL DECALS ARE INDICATED BY BOLD TYPE IN A BOLD BOX, E.G., **ON/OFF**
- 8 ALL RELAYS ARE SHOWN IN THE DE-ENERGIZED STATE

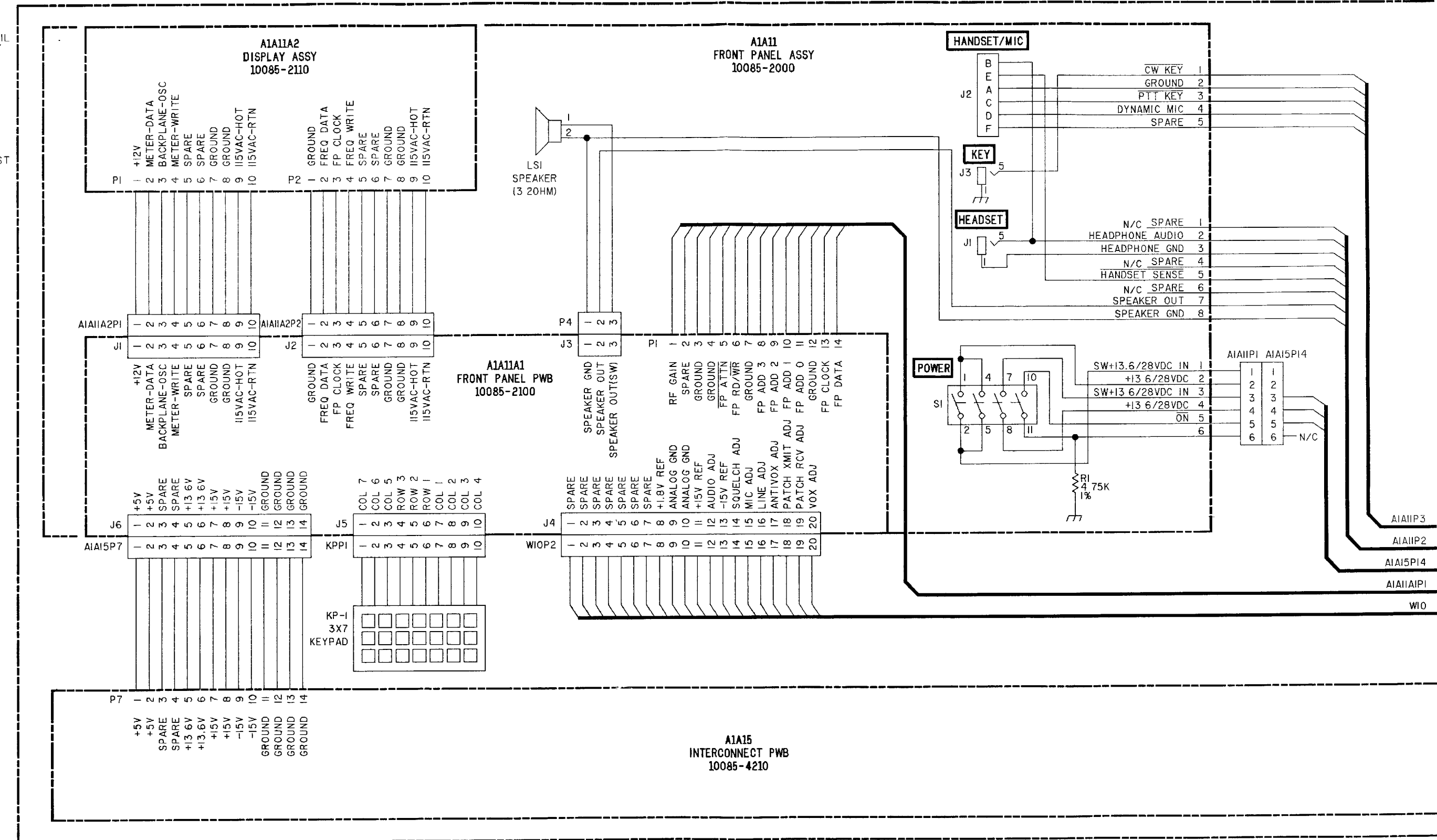

FO-2. TRANSCIVER ASSY, A1, INTERCONNECTION DIAGRAM (Sheet 1 of 13)



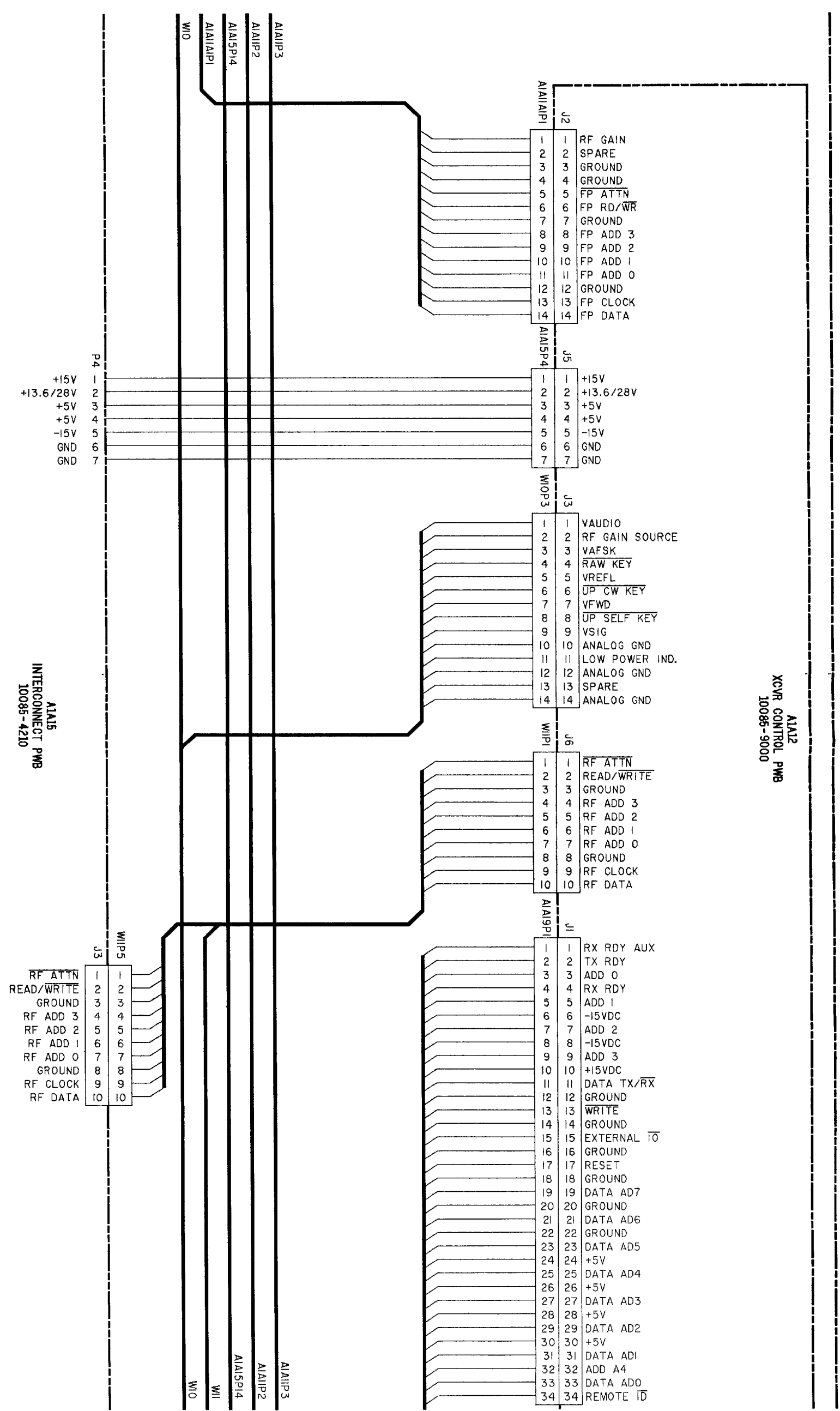

FO-2. TRANSCIVER ASSY, A1,  
INTERCONNECTION DIAGRAM  
(Sheet 2 of 13)



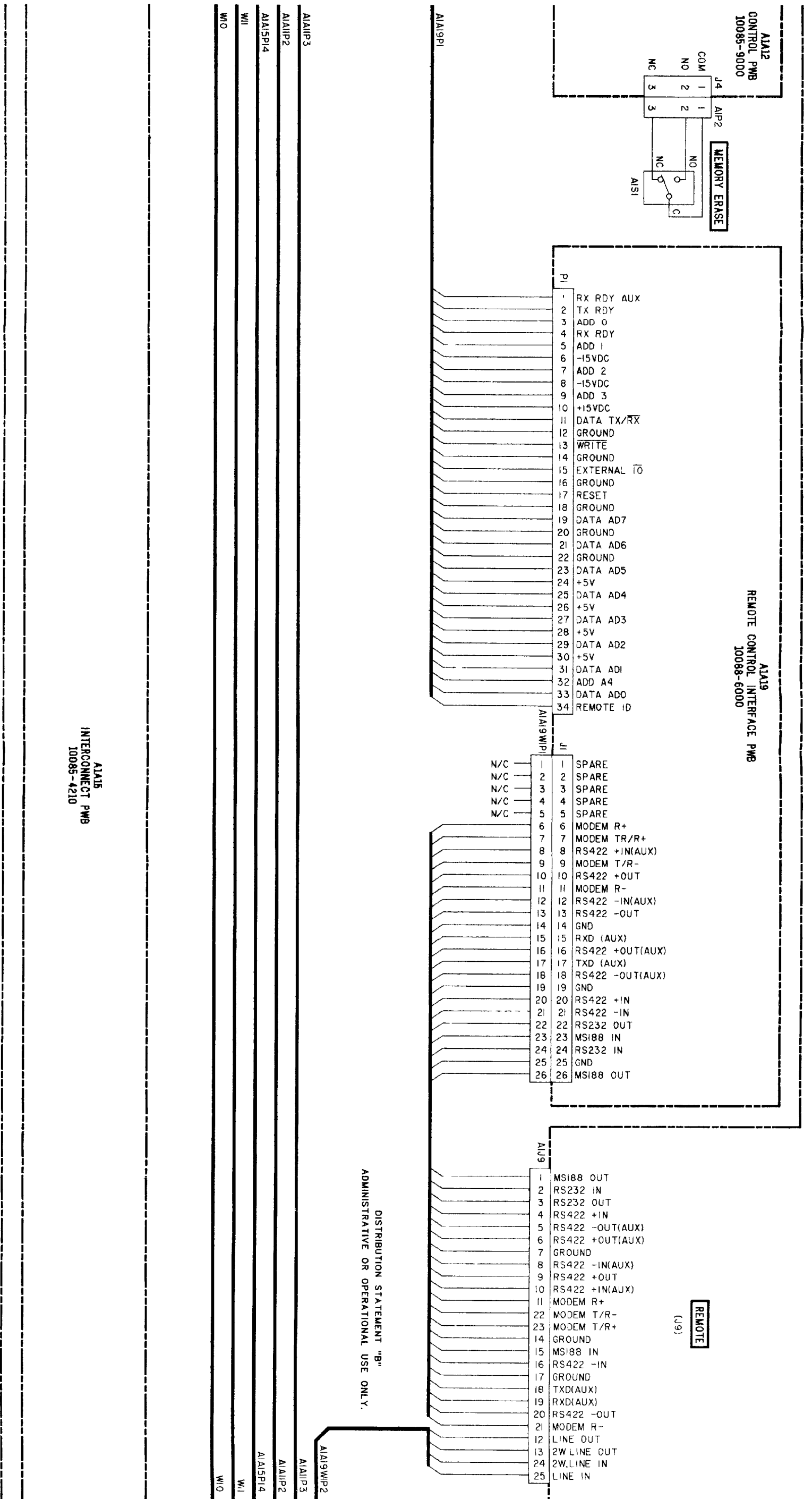

DISTRIBUTION STATEMENT "B"  
ADMINISTRATIVE OR OPERATIONAL USE ONLY.

A1A15  
INTERCONNECT PMB  
10085-4210









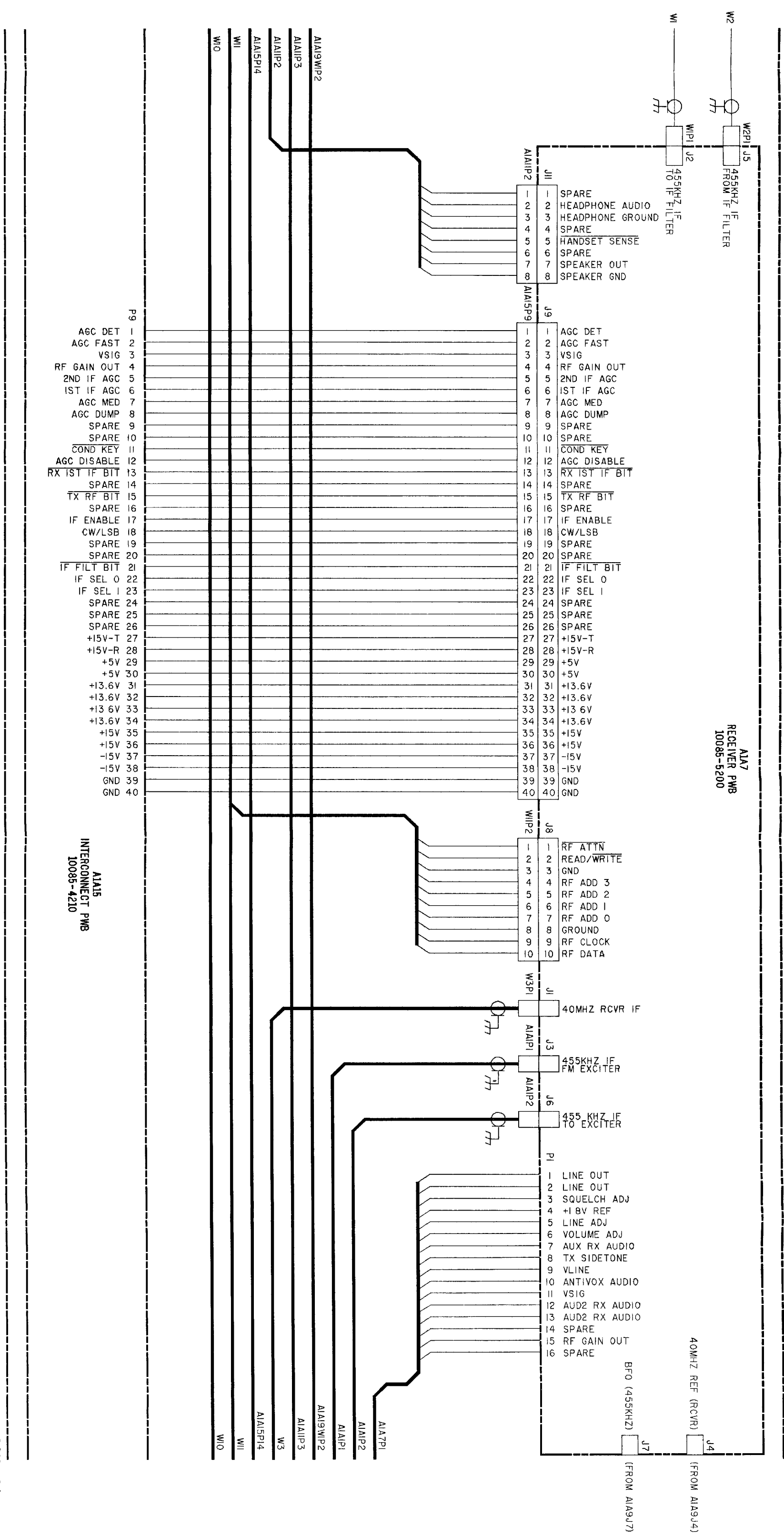

FO-2. TRANSCIVER ASSY, A1.  
INTERCONNECTION DIAGRAM  
(Sheet 5 of 13)



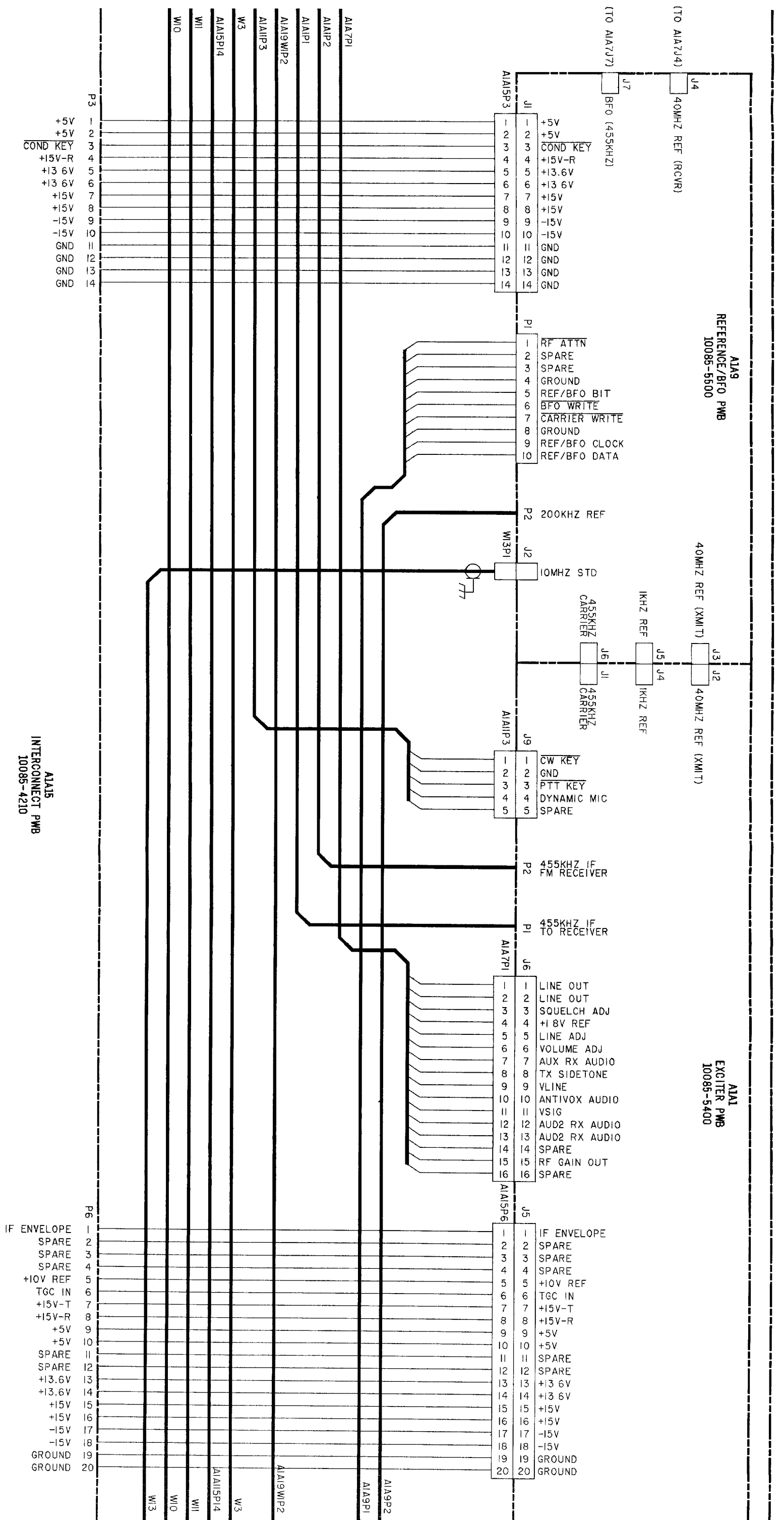

FO-2. TRANSCIVER ASSY, A1,  
INTERCONNECTION DIAGRAM  
(Sheet 6 of 13)



A1A1  
EXCITER PWB  
10085-5400

TO FRONT PANEL ASSY, A1A1A1U4  
TO CONTROL PWB, A1A2U3

TO INTERCONNECT, A1A1S7  
TO NBSV, A1U4  
TO AUDIO INFC, A1A6U1

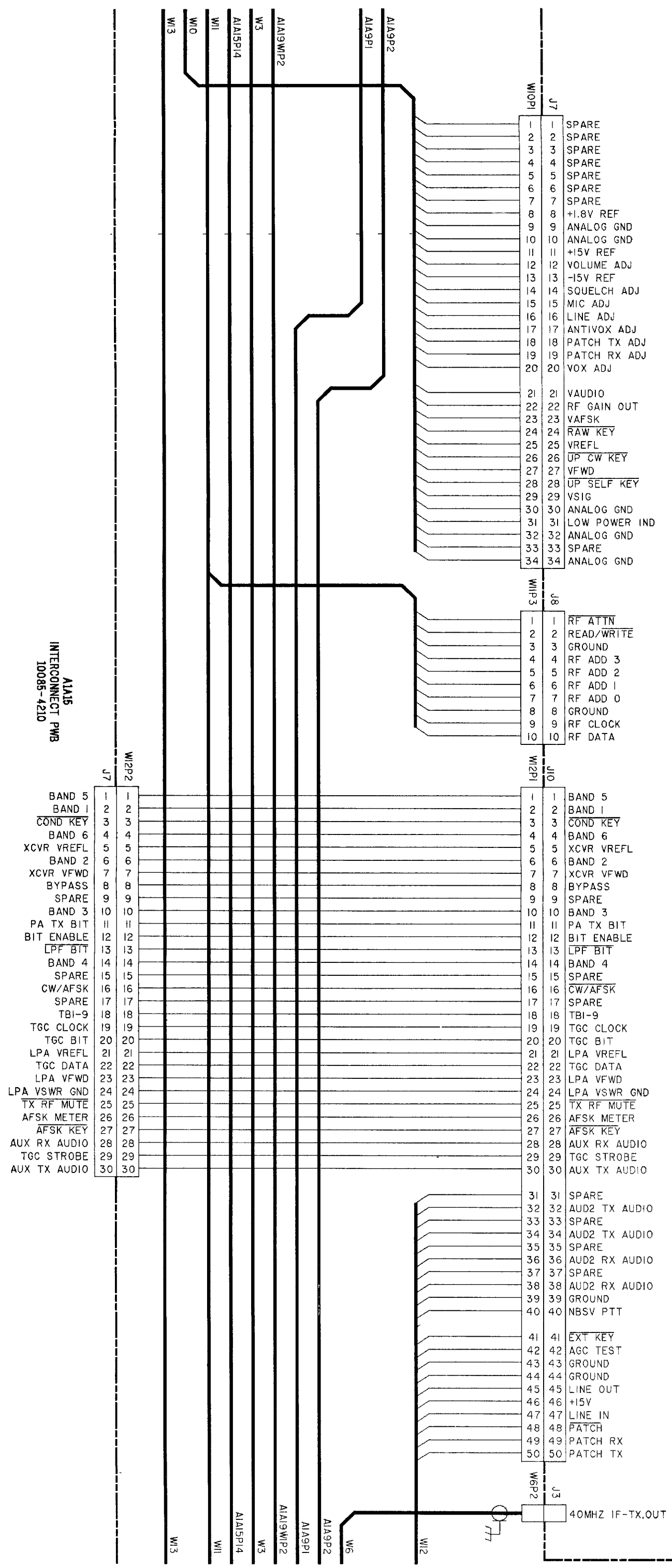

FO-2. TRANSCIVER ASSY, A1,  
INTERCONNECTION DIAGRAM  
(Sheet 7 of 13)



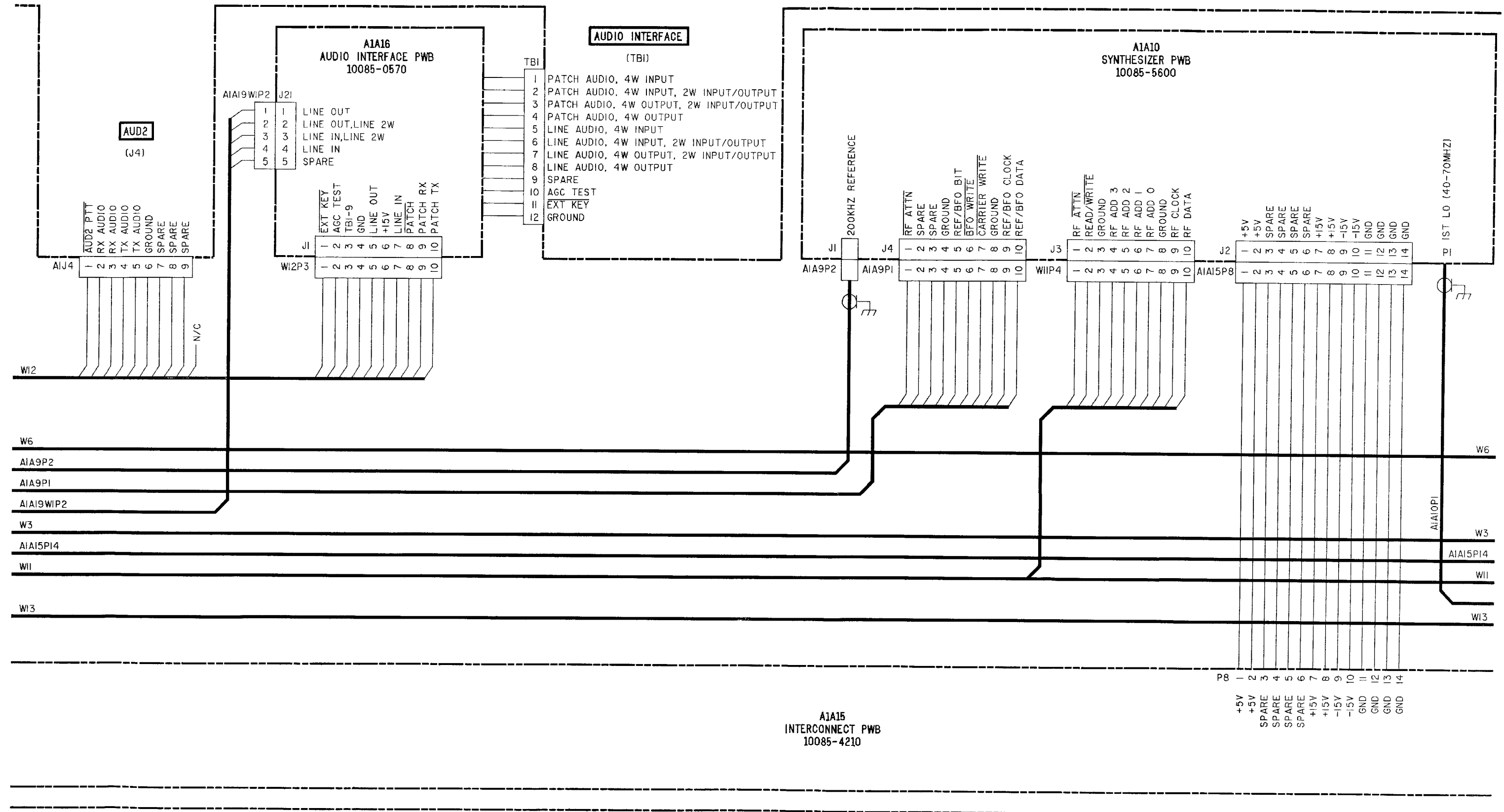

FO-2. TRANSCEIVER ASSY, A1,  
INTERCONNECTION DIAGRAM  
(Sheet 8 of 13)





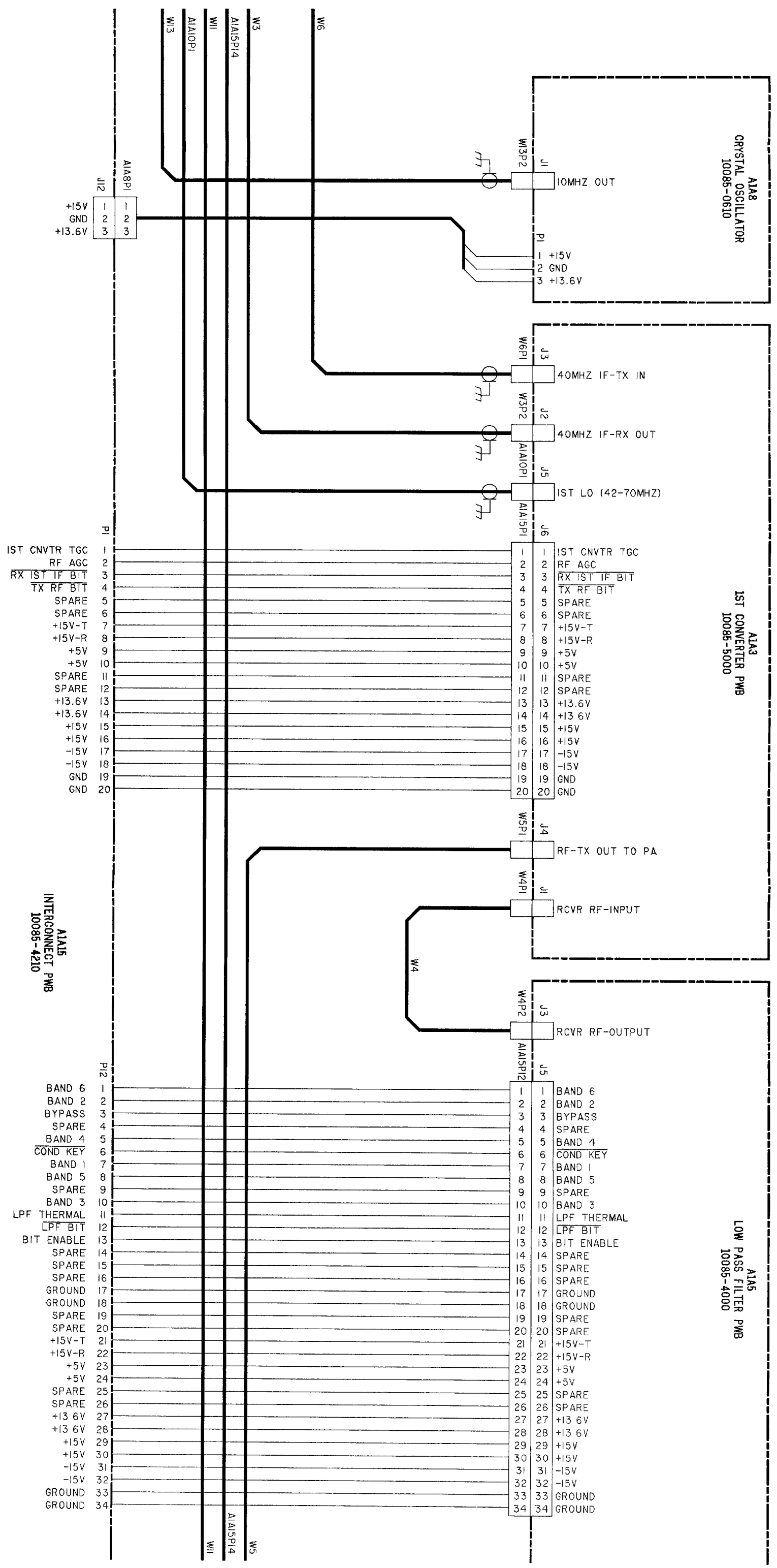

FO-2. TRANSCIEVER ASSY, A1,  
INTERCONNECTION DIAGRAM  
(Sheet 9 of 13)



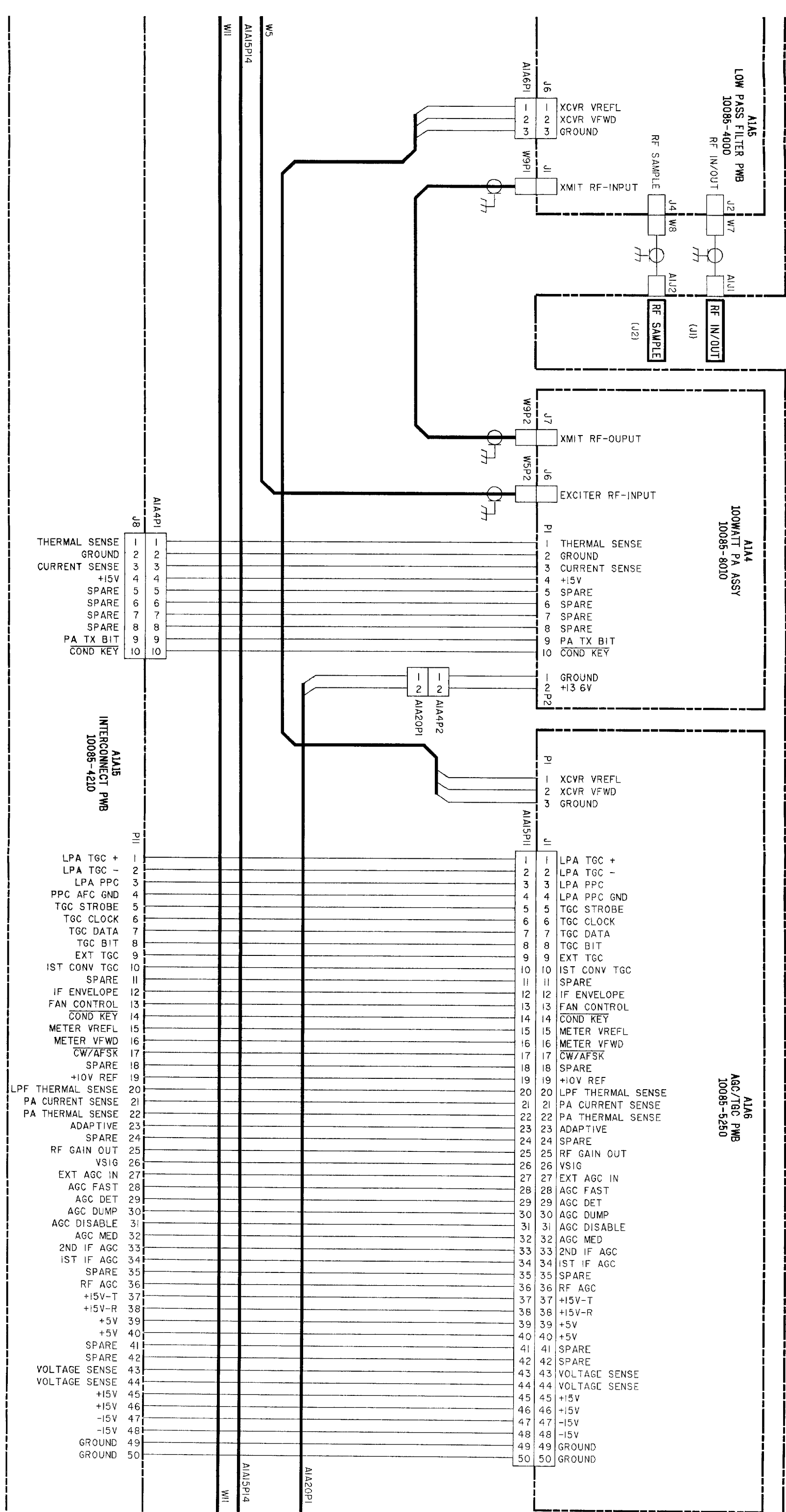

FO-2. TRANSCIVER ASSY, A1,  
INTERCONNECTION DIAGRAM  
(Sheet 10 of 13)



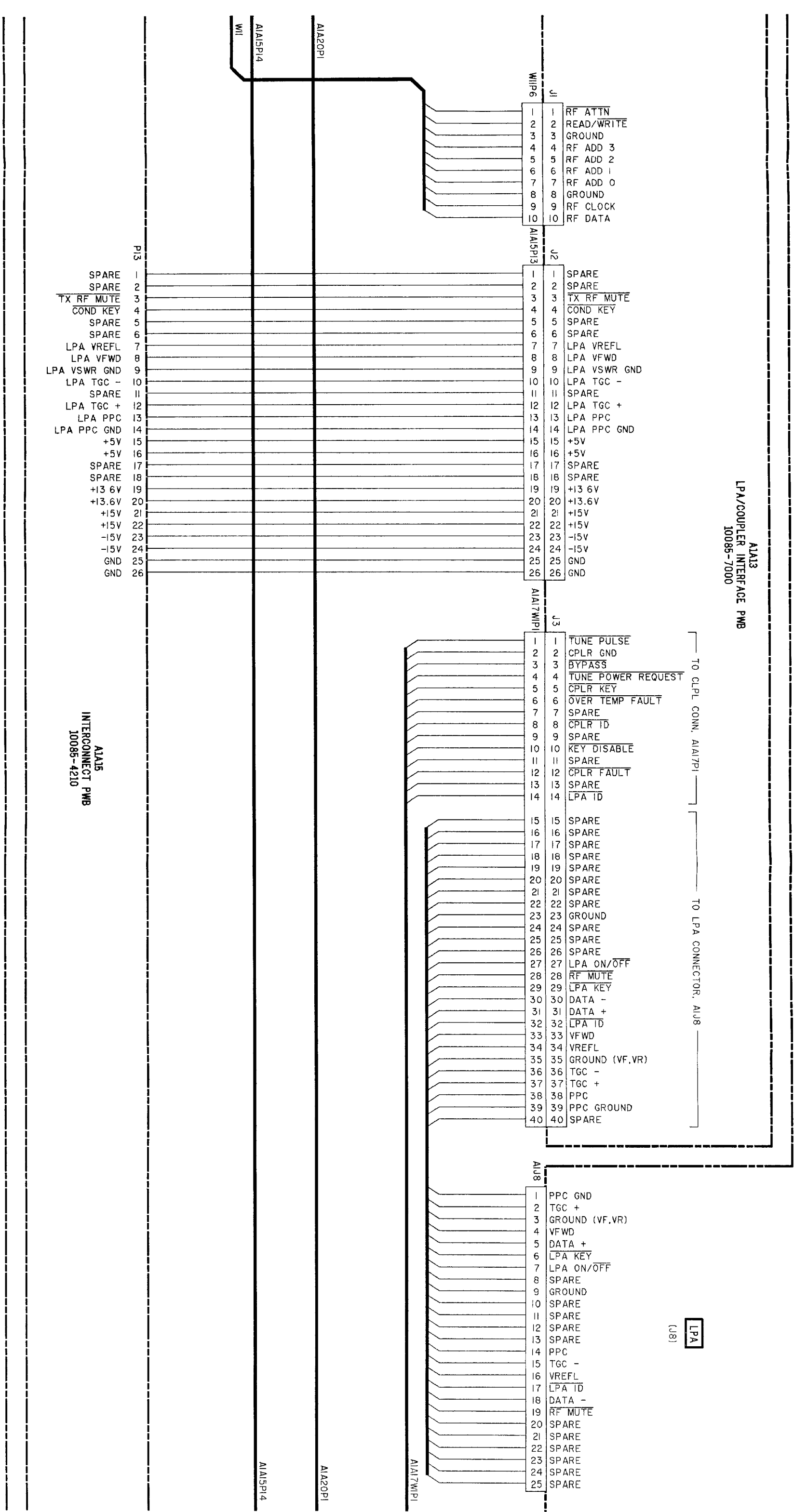

FO-2. TRANSCIVER ASSY, A1,  
INTERCONNECTION DIAGRAM  
(Sheet 11 of 13)



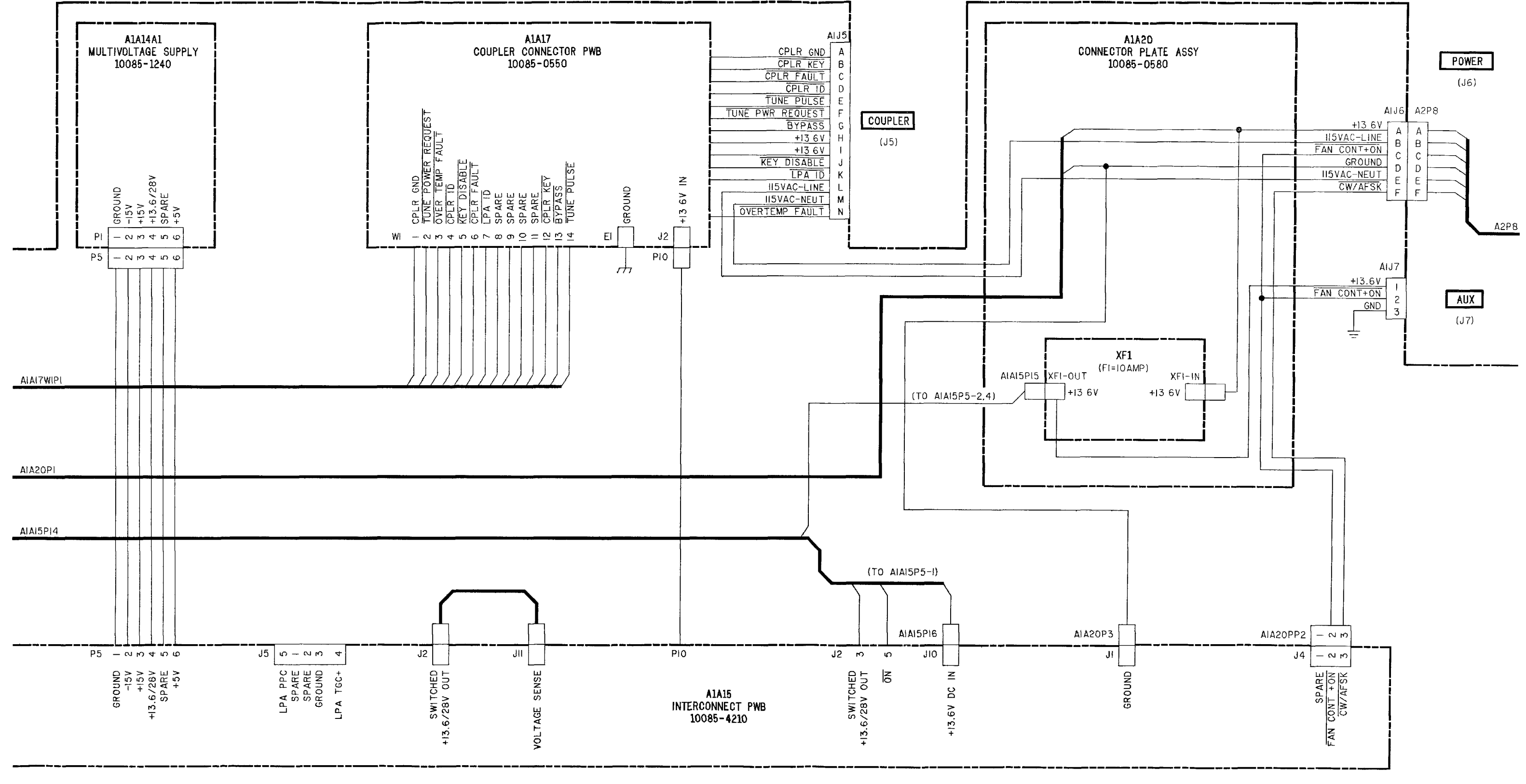

FO-2. TRANSCEIVER ASSY, A1,  
INTERCONNECTION DIAGRAM  
(Sheet 12 of 13)





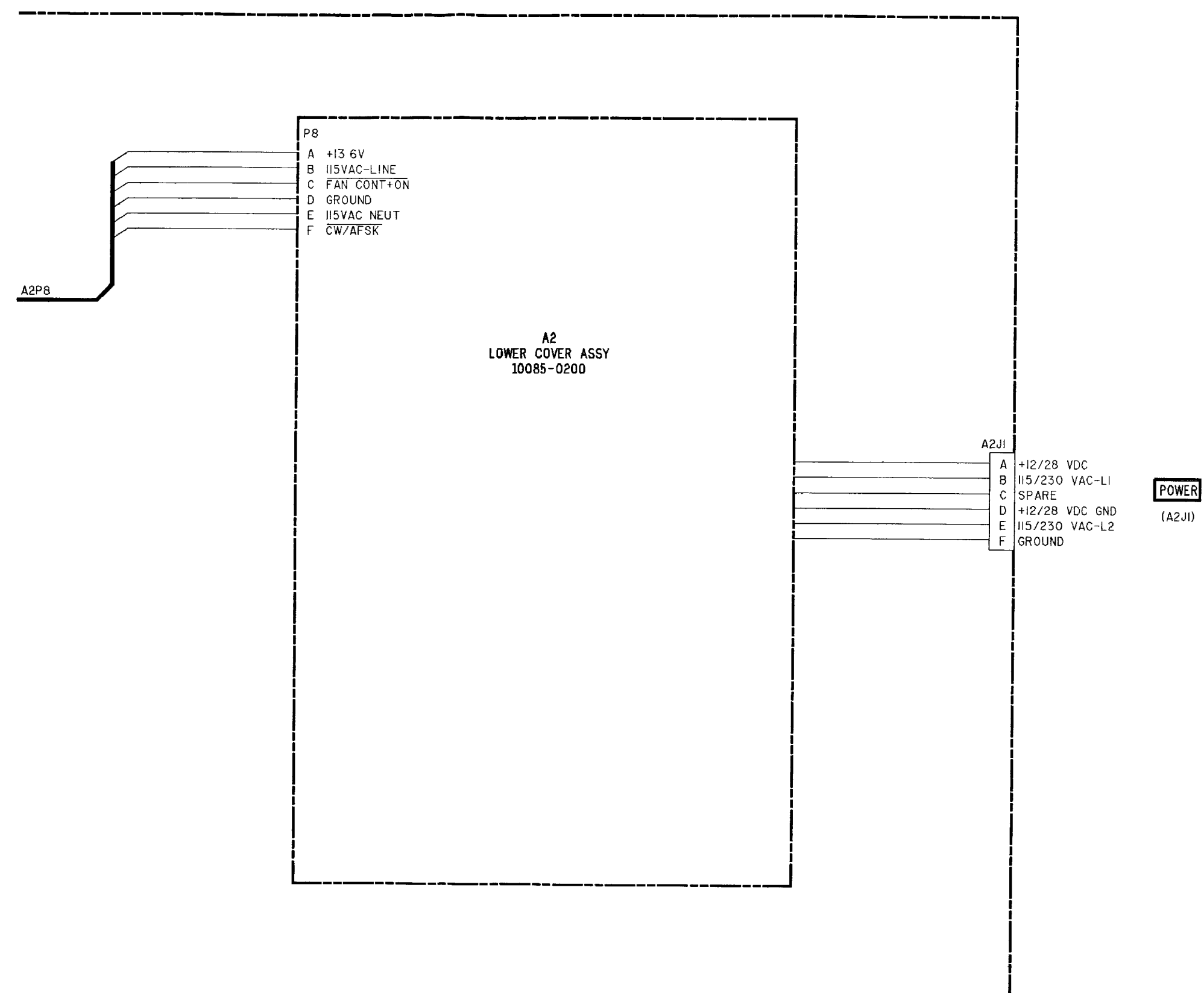

FO-2. TRANSCEIVER ASSY, A1,  
INTERCONNECTION DIAGRAM  
(Sheet 13 of 13)



NOTE UNLESS OTHERWISE SPECIFIED:

1. PARTIAL REFERENCE DESIGNATIONS ARE SHOWN FOR DETAIL PARTS. PREFIX THESE WITH UNIT NO. AND/OR ASSEMBLY DESIGNATIONS SHOWN ON DRAWING TO OBTAIN COMPLETE DESIGNATIONS.
2. ALL RESISTOR VALUES ARE IN OHMS, 1/4W, ±5%
3. ALL CAPACITOR VALUES ARE IN MICROFARADS (µF).
4. ALL INDUCTANCE VALUES ARE IN MICROHENRIES (µH)
5. VENDOR PART NO. CALLOUTS ARE FOR REFERENCE ONLY. COMPONENTS ARE SUPPLIED PER PART NO. IN PARTS LIST
6. DC RESISTANCES OF INDUCTIVE ELEMENTS (CHOKES, COILS, MOTOR WINDINGS, ETC.) ARE LESS THAN 1 OHM.
7. PANEL DECALS ARE INDICATED BY BOLD TYPE IN A BOLD BOX, E.G., **ON/OFF**
8. ALL RELAYS ARE SHOWN IN THE DE-ENERGIZED STATE.

HIGHEST REFERENCE DESIGNATION	
REFERENCE DESIGNATIONS NOT USED	

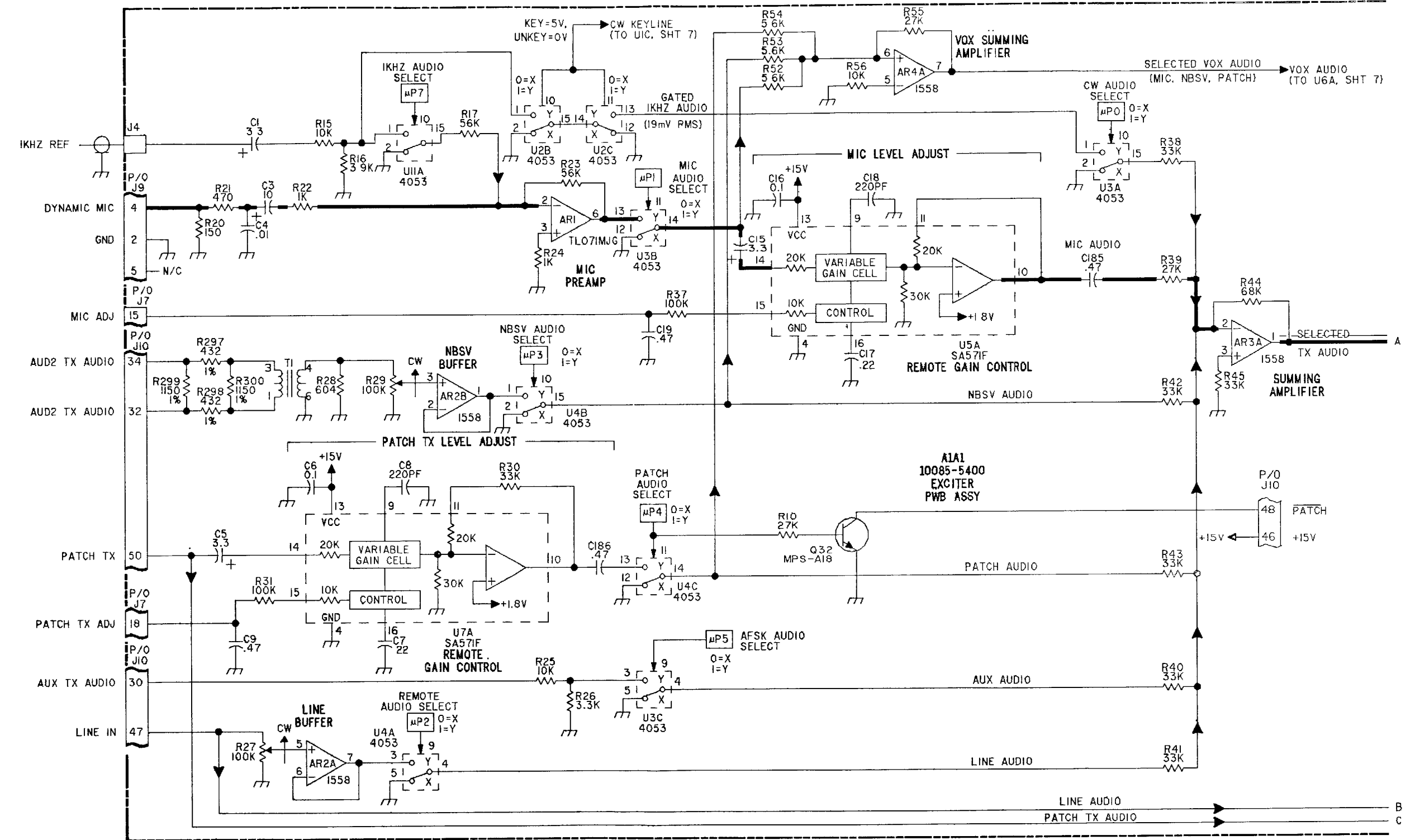

FO-3. EXCITER PWB ASSY, A1A1  
(Sheet 1 of 11)



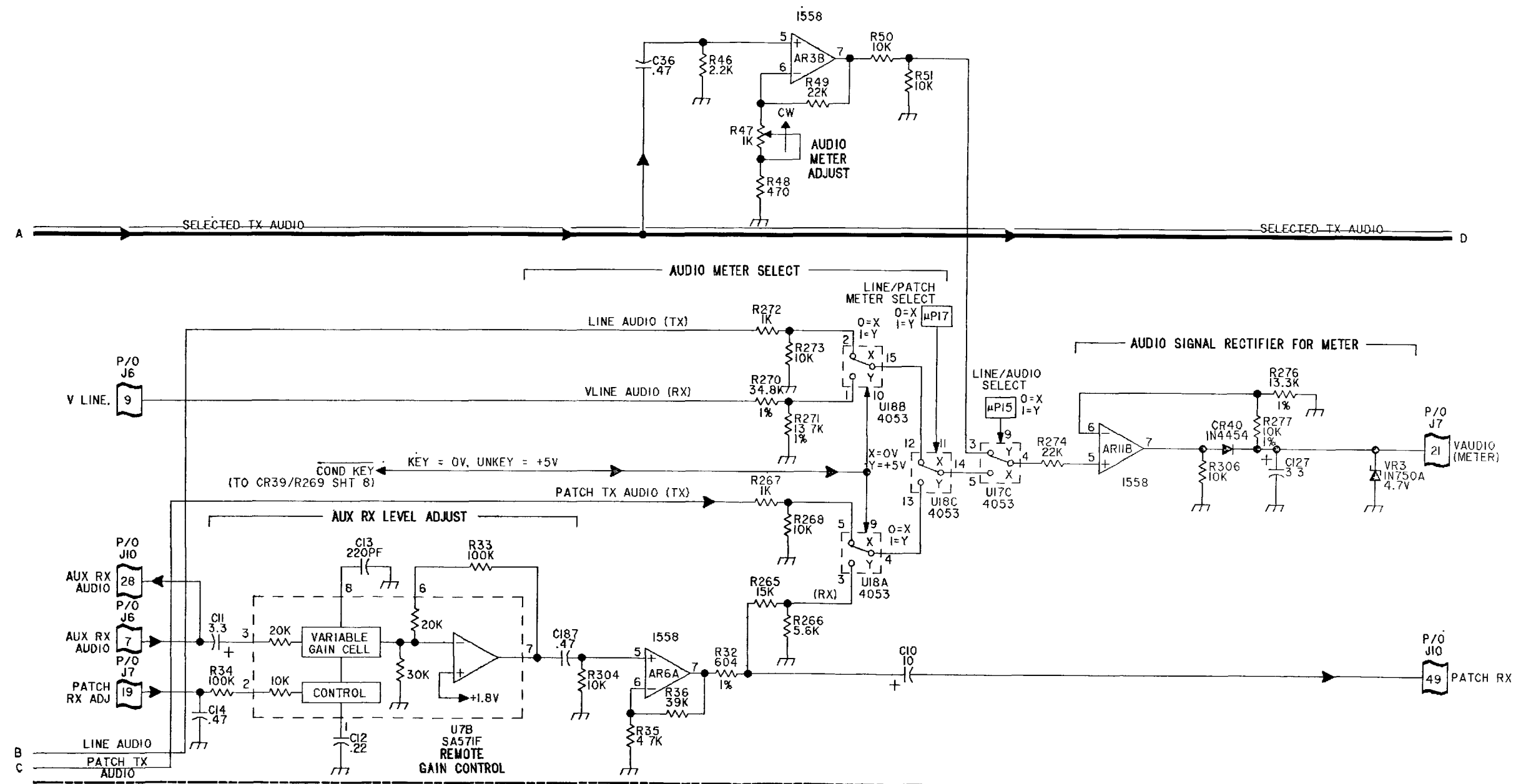

FO-3. EXCITER PWB ASSY, A1A1  
(Sheet 2 of 11)



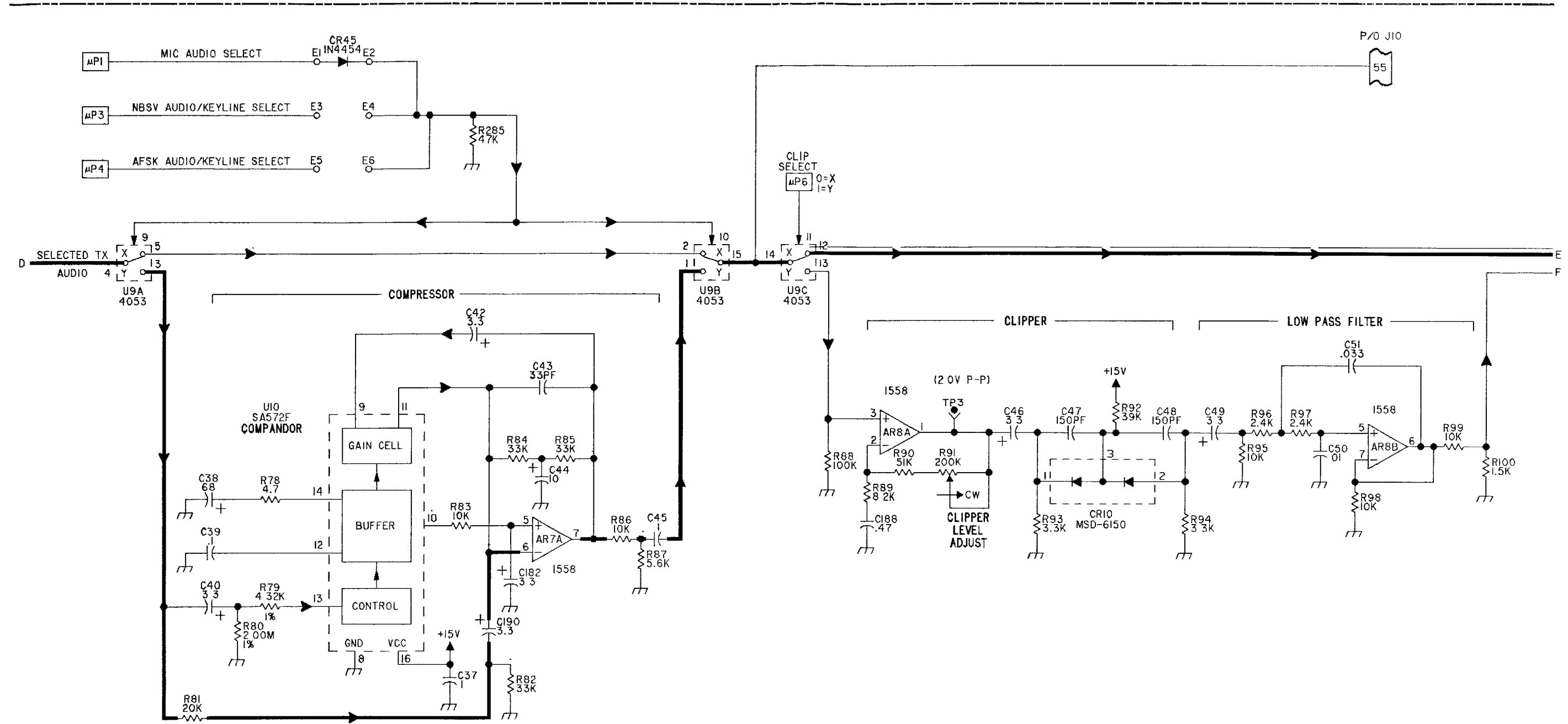





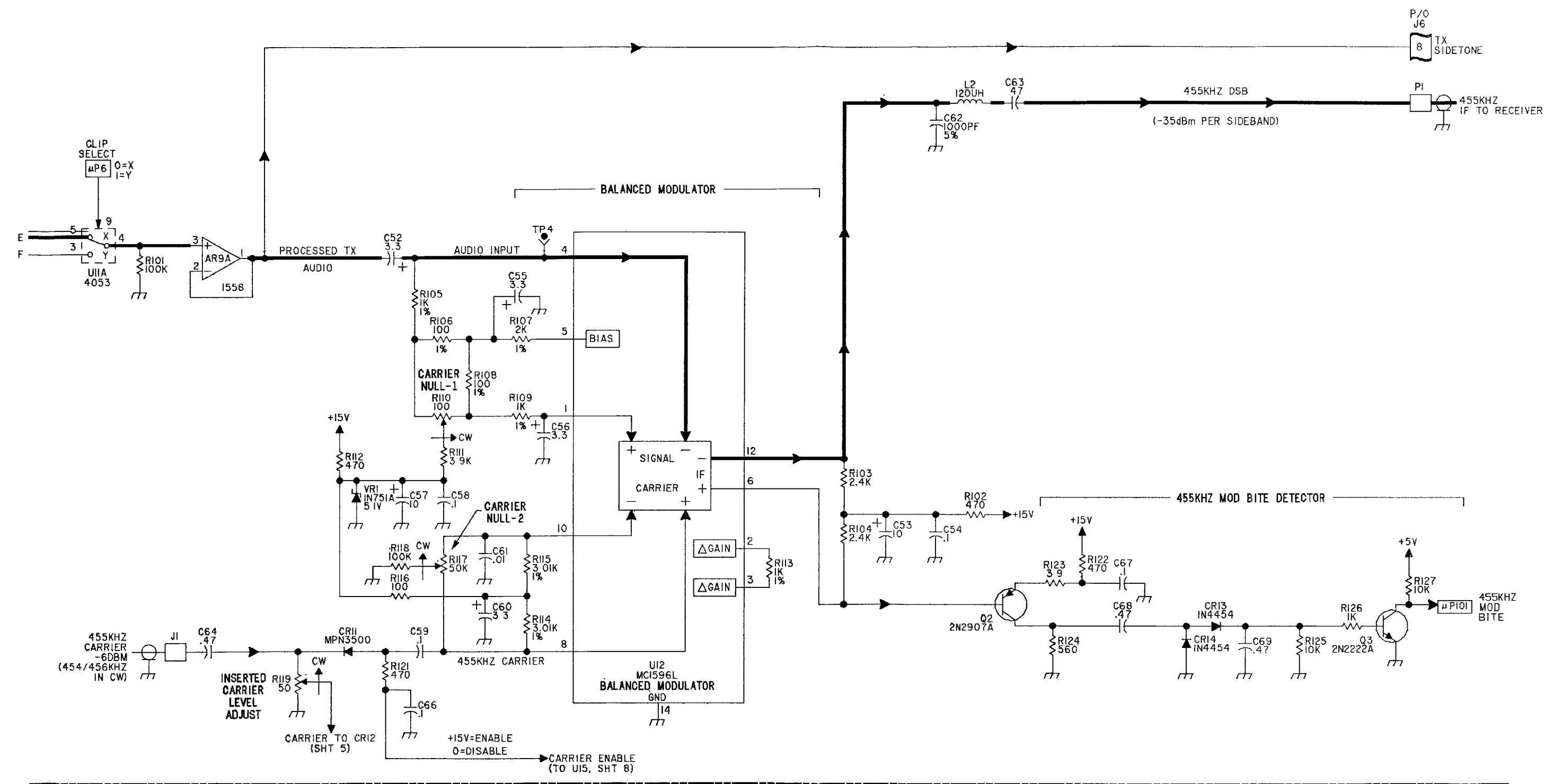

FO-3. EXCITER PWB ASSY, A1A1  
(Sheet 4 of 11)



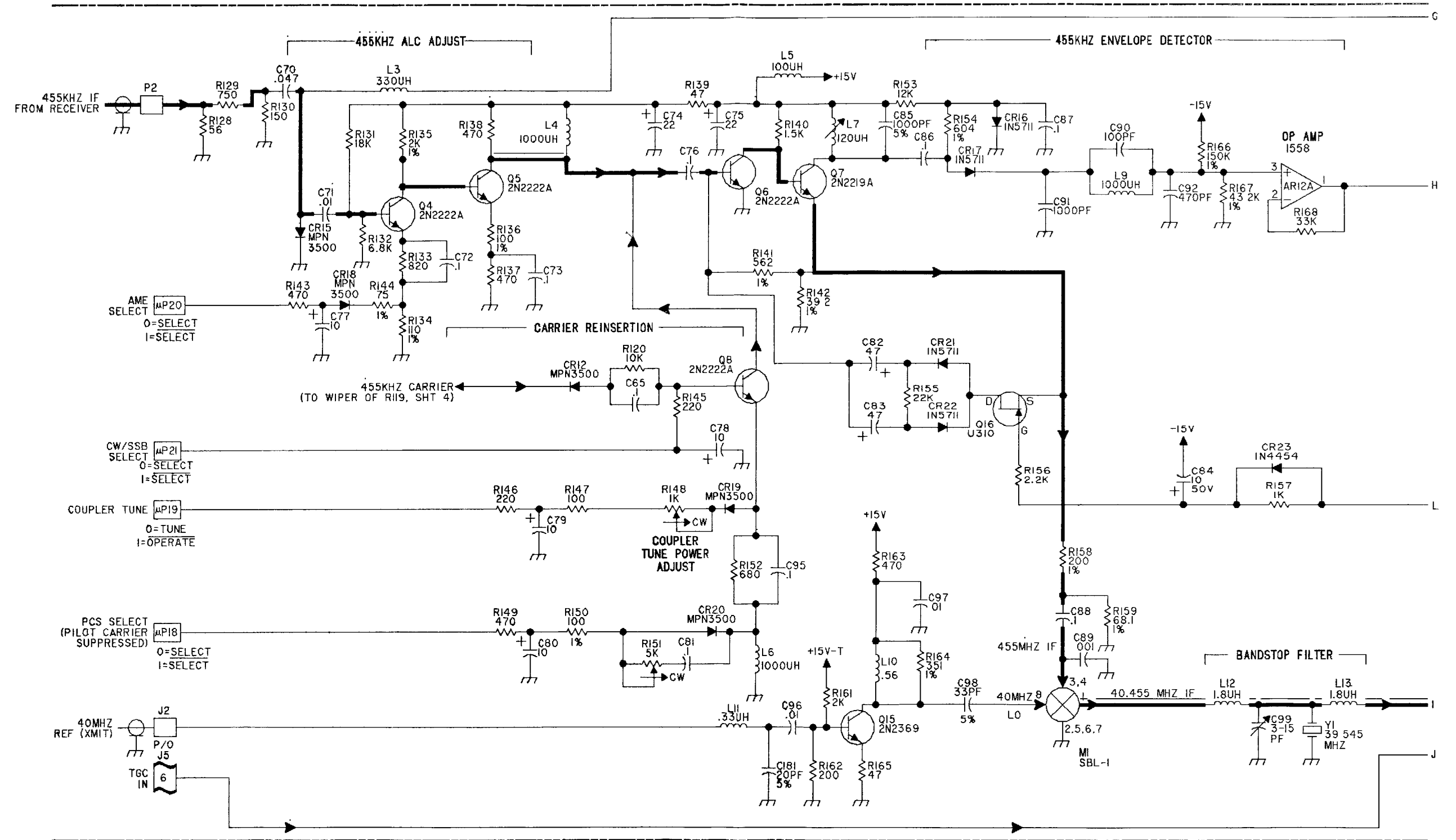

FO-3. EXCITER PWB ASSY, A1A1  
(Sheet 5 of 11)



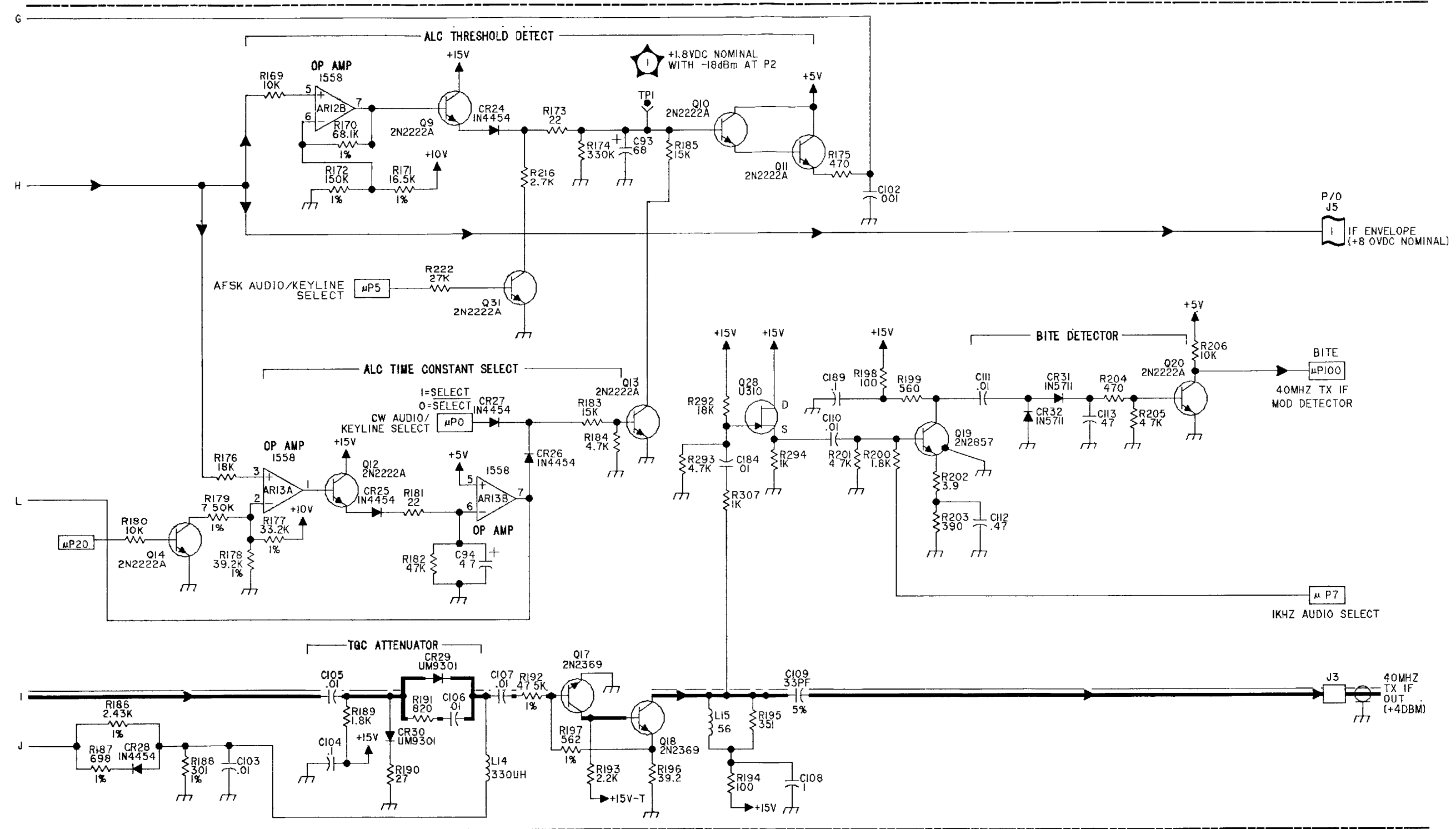

FO-3. EXCITER PWB ASSY, A1A1  
(Sheet 6 of 11)



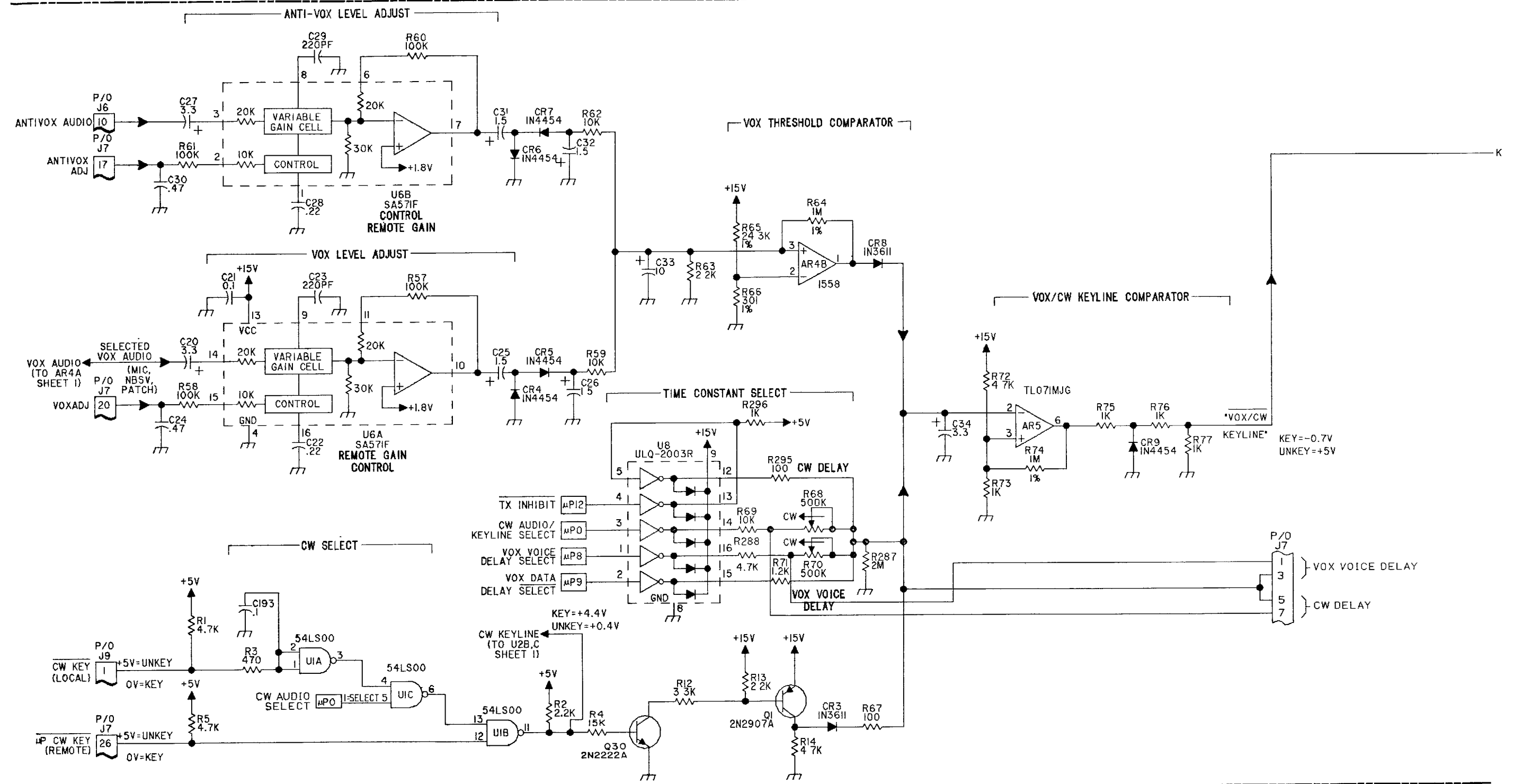

FO-3. EXCITER PWB ASSY, A1A1  
(Sheet 7 of 11)





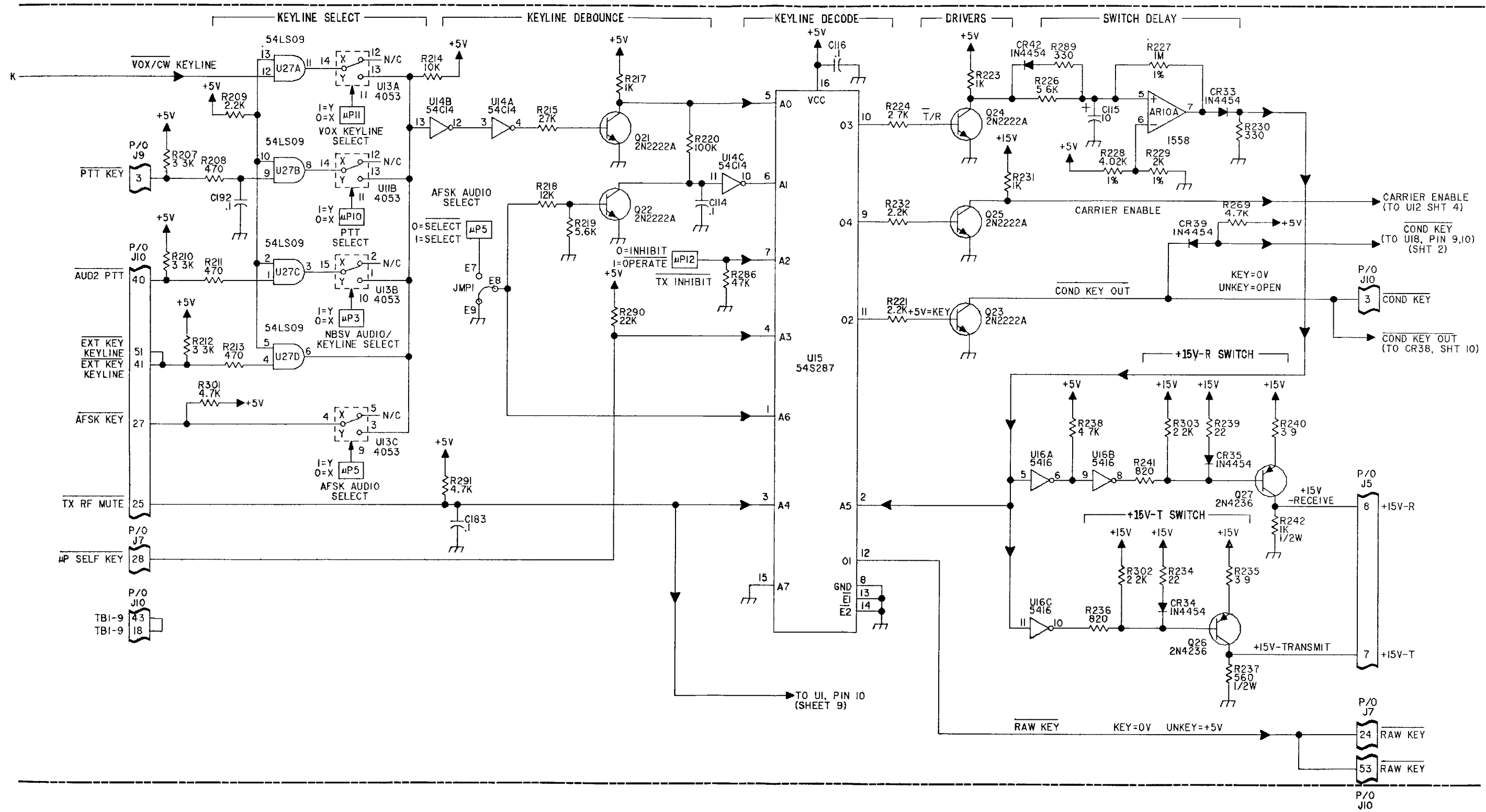

FO-3. EXCITER PWB ASSY, A1A1  
(Sheet 8 of 11)



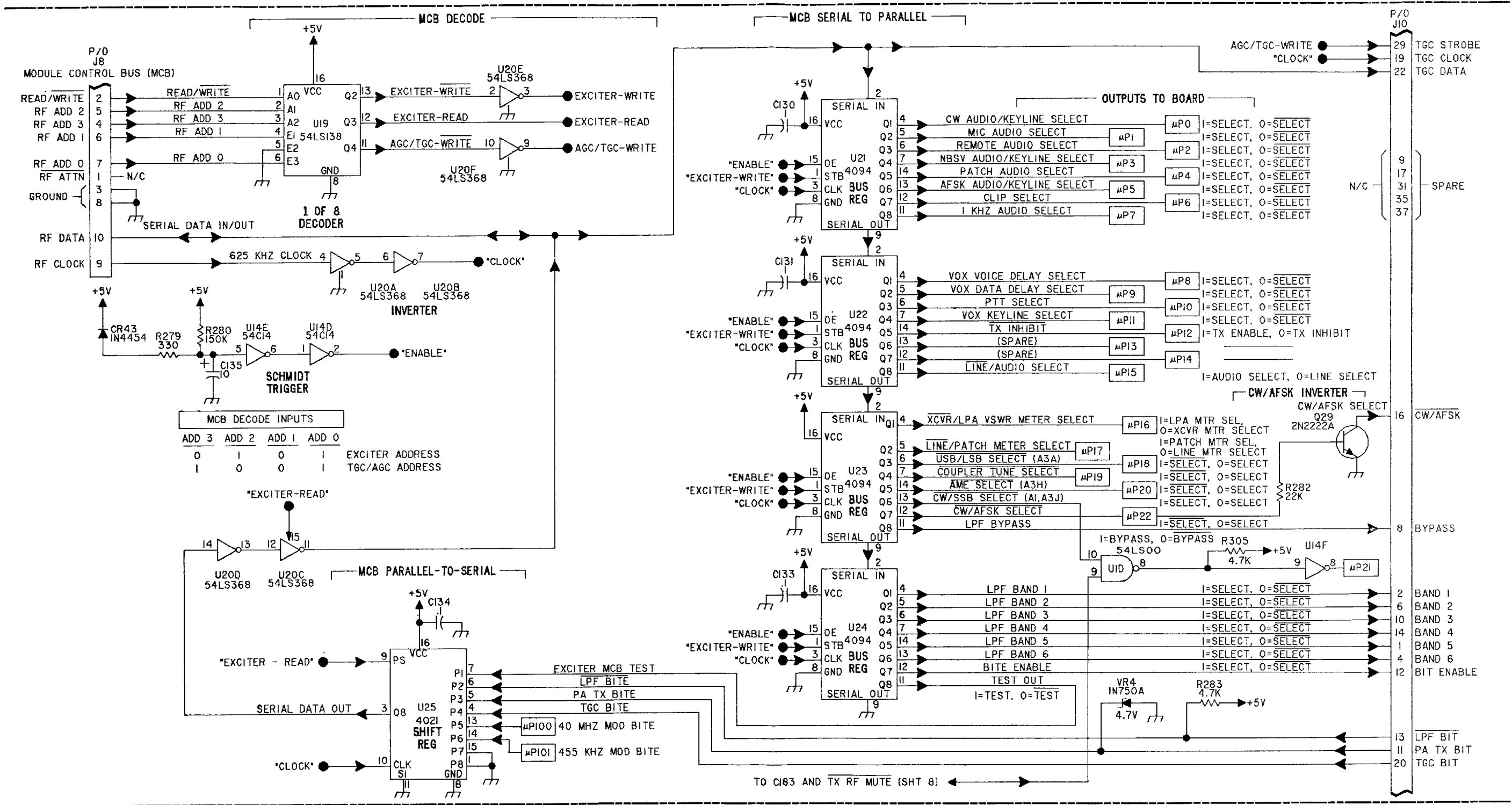

FO-3. EXCITER PWB ASSY, A1A1 (Sheet 9 of 11)



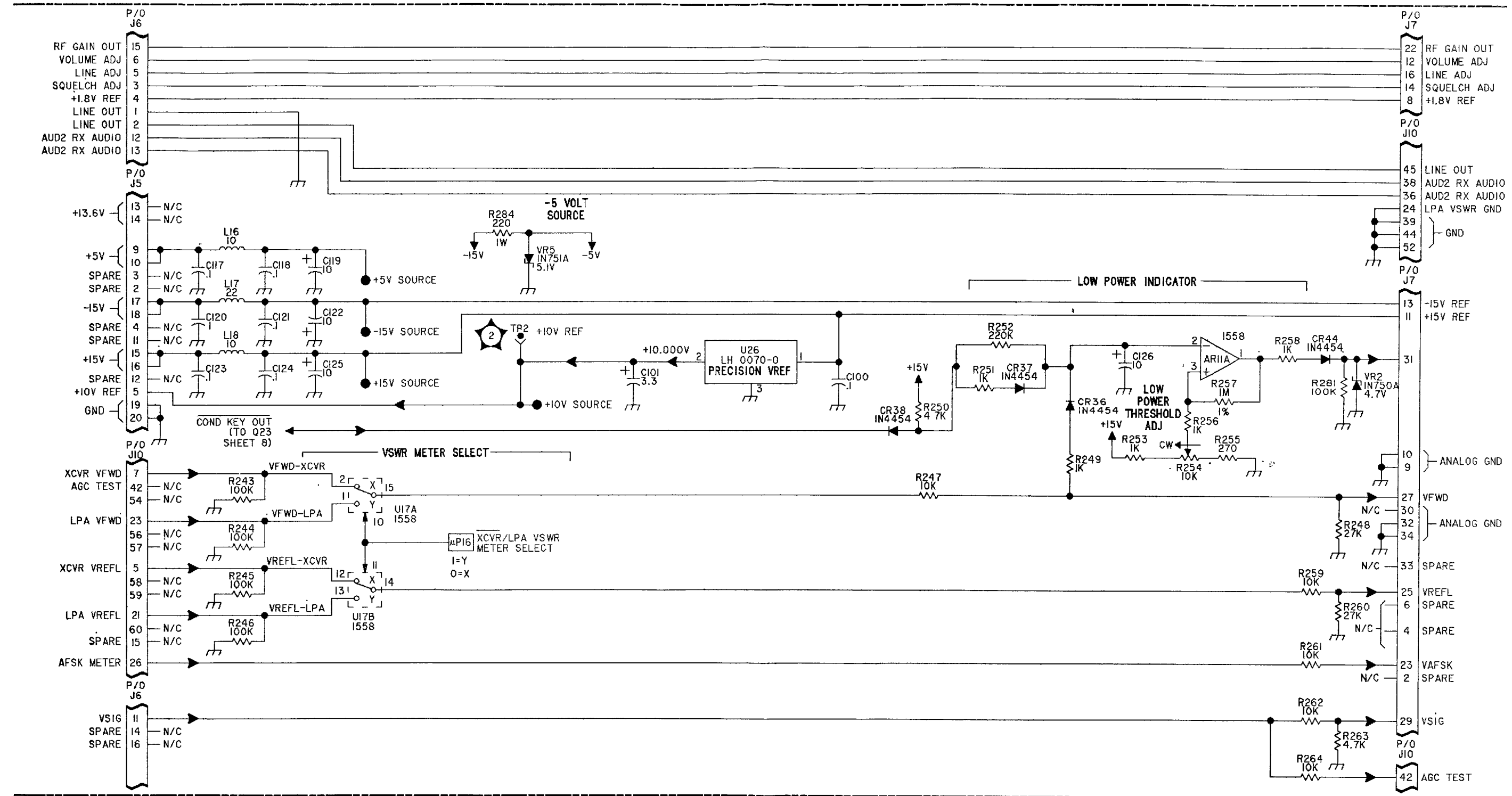

FO-3. EXCITER PWB ASSY, A1A1  
(Sheet 10 of 11)



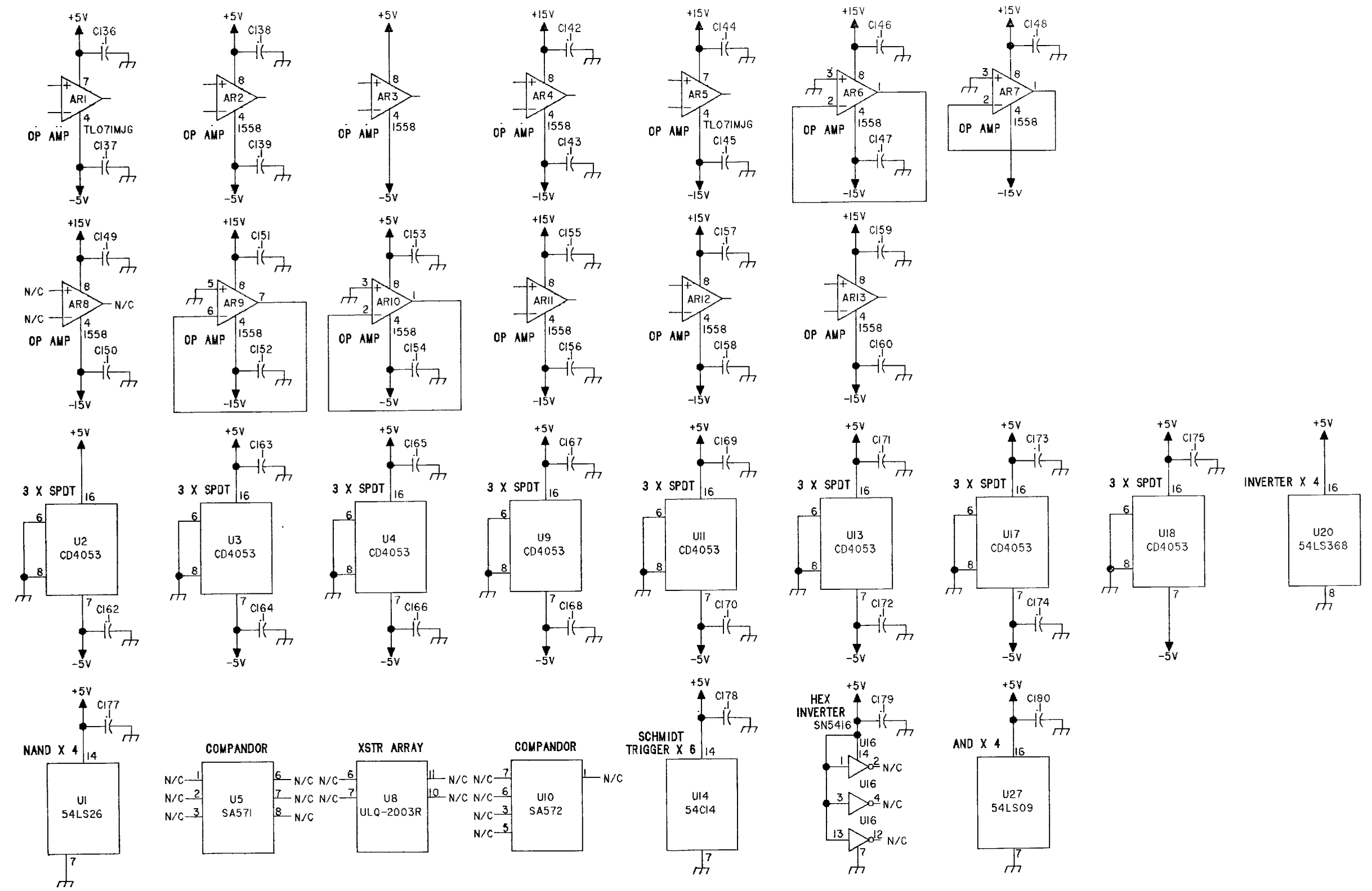

FO-3. EXCITER PWB ASSY, A1A1  
(Sheet 11 of 11)





NOTE: UNLESS OTHERWISE SPECIFIED:

1. PARTIAL REFERENCE DESIGNATIONS ARE SHOWN FOR DETAIL PARTS. PREFIX THESE WITH UNIT NO. AND/OR ASSEMBLY DESIGNATIONS SHOWN ON DRAWING TO OBTAIN COMPLETE DESIGNATIONS.
2. ALL RESISTOR VALUES ARE IN OHMS, 1/4W, ±5%
3. ALL CAPACITOR VALUES ARE IN MICROFARADS (µF).
4. ALL INDUCTANCE VALUES ARE IN MICROHENRIES (µH)
5. VENDOR PART NO. CALLOUTS ARE FOR REFERENCE ONLY. COMPONENTS ARE SUPPLIED PER PART NO. IN PARTS LIST.
6. DC RESISTANCES OF INDUCTIVE ELEMENTS (CHOKES, COILS, MOTOR WINDINGS, ETC.) ARE LESS THAN 1 OHM.
7. PANEL DECALS ARE INDICATED BY BOLD TYPE IN A BOLD BOX, E.G., **ON/OFF**.
8. ALL RELAYS ARE SHOWN IN THE DE-ENERGIZED STATE.

HIGHEST REFERENCE DESIGNATION	
REFERENCE DESIGNATIONS NOT USED	

UNUSED GATES

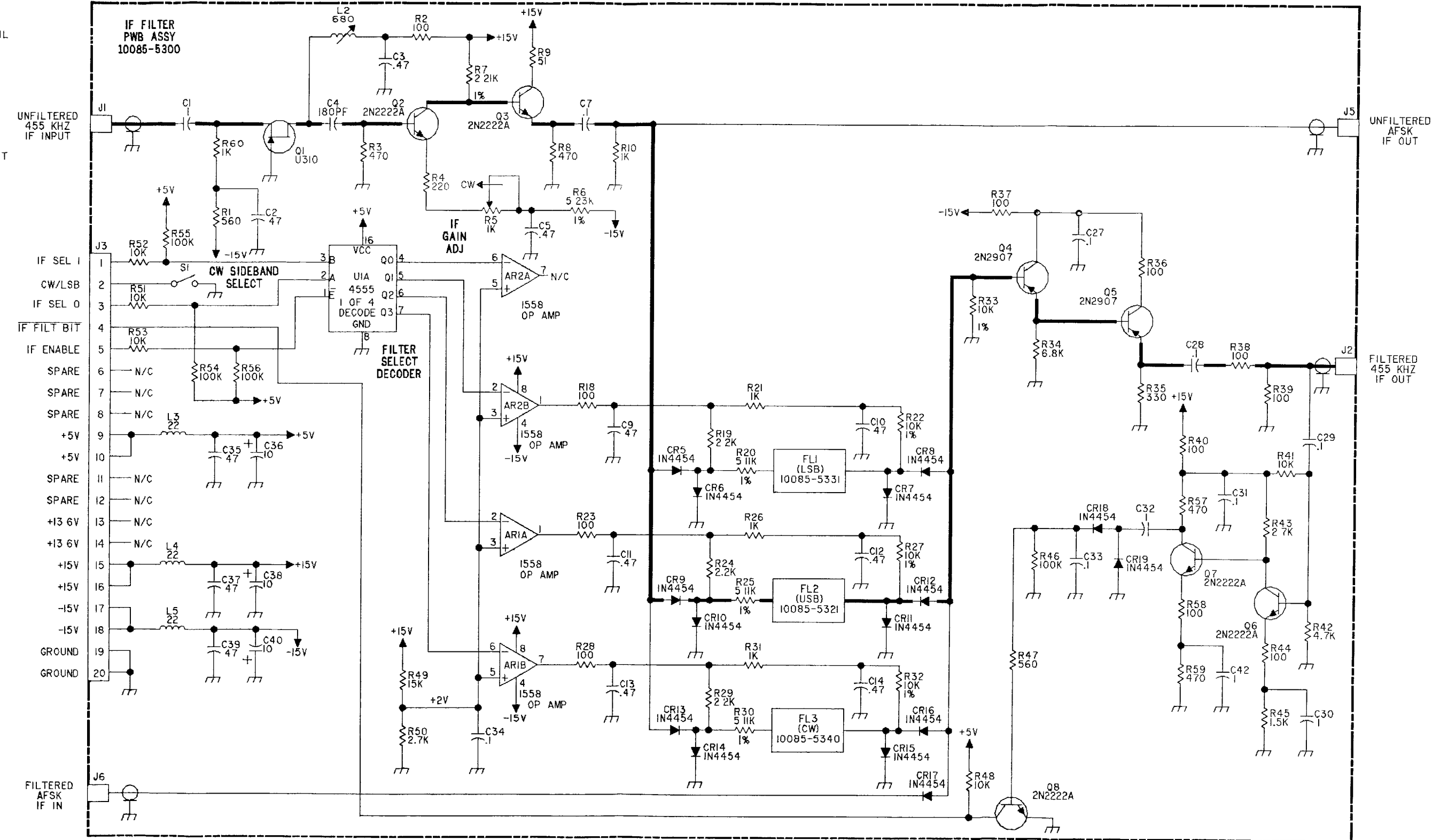
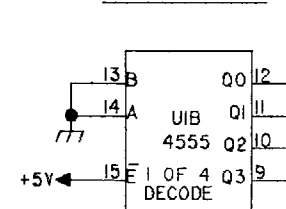

FO-4. IF FILTER PWB ASSY, A1A2

FP-51(FP-52 Blank)



NOTE UNLESS OTHERWISE SPECIFIED:

1. PARTIAL REFERENCE DESIGNATIONS ARE SHOWN FOR DETAIL PARTS. PREFIX THESE WITH UNIT NO. AND/OR ASSEMBLY DESIGNATIONS SHOWN ON DRAWING TO OBTAIN COMPLETE DESIGNATIONS.
2. ALL RESISTOR VALUES ARE IN OHMS, 1/4W, ±5%
3. ALL CAPACITOR VALUES ARE IN MICROFARADS (UF).
4. ALL INDUCTANCE VALUES ARE IN MICROHENRIES (UH).
5. VENDOR PART NO. CALLOUTS ARE FOR REFERENCE ONLY. COMPONENTS ARE SUPPLIED PER PART NO. IN PARTS LIST.
6. DC RESISTANCES OF INDUCTIVE ELEMENTS (CHOKES, COILS, MOTOR WINDINGS, ETC.) ARE LESS THAN 1 OHM.
7. PANEL DECALS ARE INDICATED BY BOLD TYPE IN A BOLD BOX, E.G., **ON/OFF**
8. ALL RELAYS ARE SHOWN IN THE DE-ENERGIZED STATE.

HIGHEST REFERENCE DESIGNATION				
REFERENCE DESIGNATIONS NOT USED				

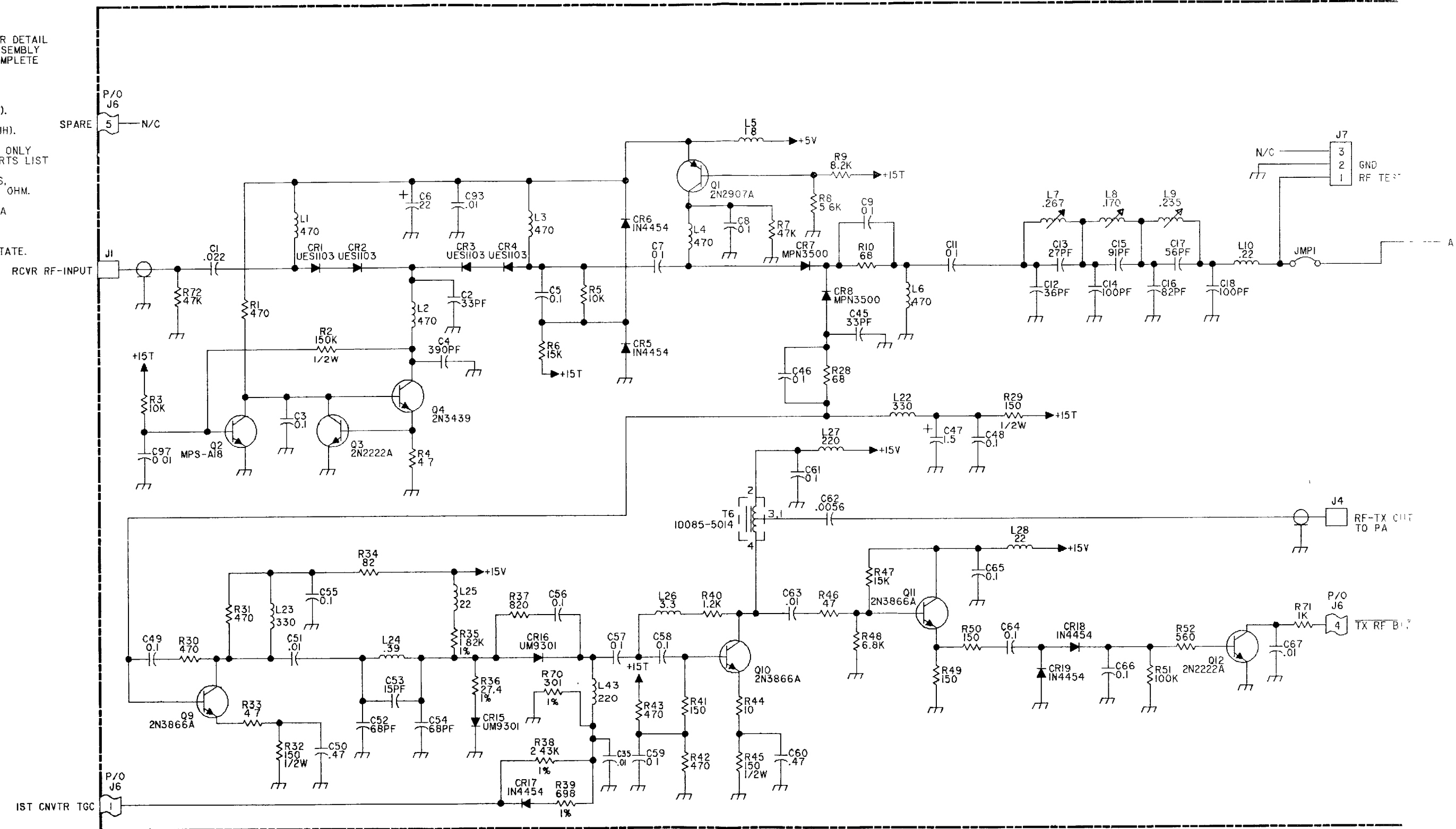

FO-5. FIRST CONVERTER PWB ASSY, A1A3 (Sheet 1 of 2)



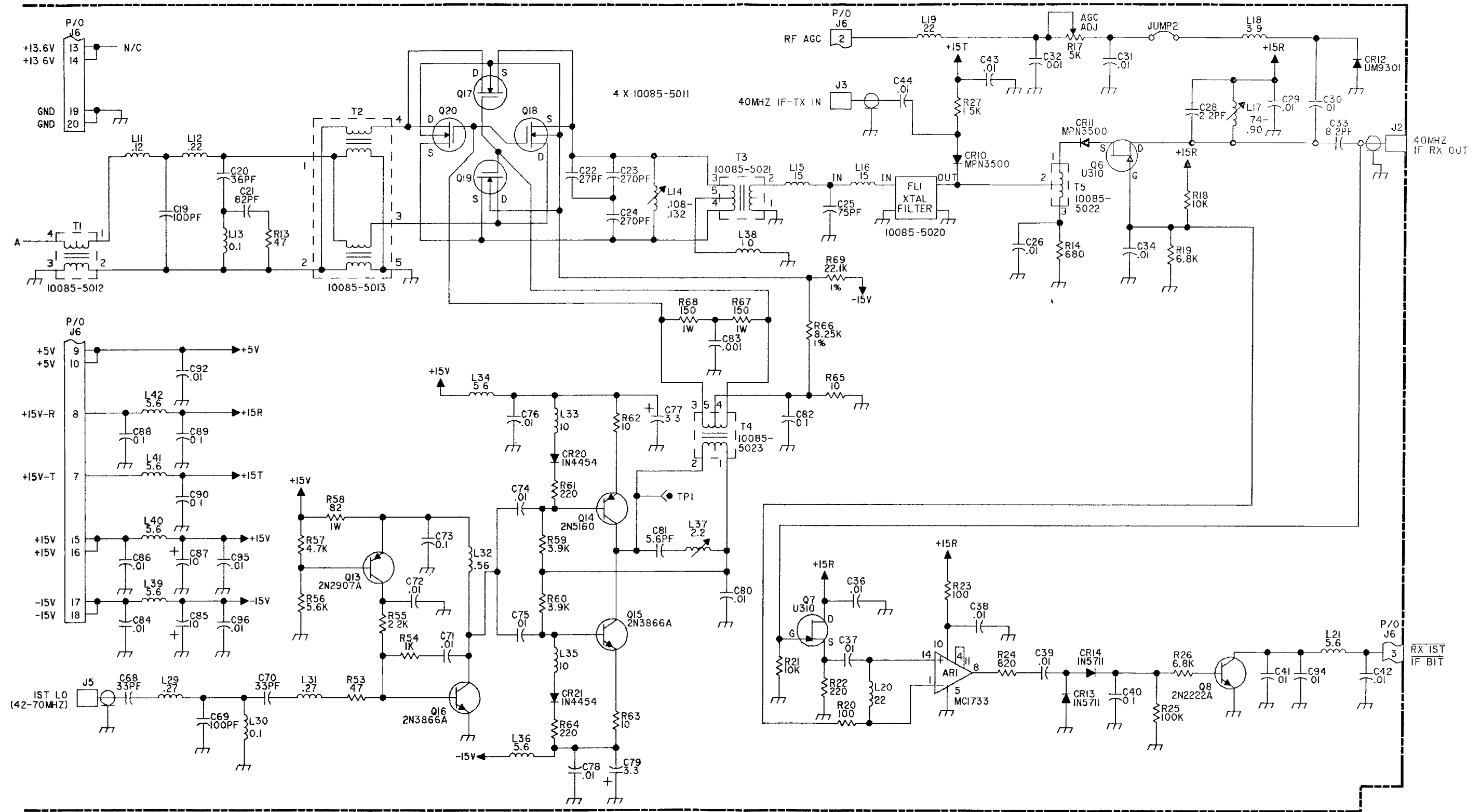

FO-5. FIRST CONVERTER PWB ASSY,  
A1A3 (Sheet 2 of 2)



NOTE UNLESS OTHERWISE SPECIFIED:

1. PARTIAL REFERENCE DESIGNATIONS ARE SHOWN FOR DETAIL PARTS. PREFIX THESE WITH A1A4 AND/OR ASSEMBLY DESIGNATIONS SHOWN ON DRAWING TO OBTAIN COMPLETE DESIGNATIONS.
2. ALL RESISTOR VALUES ARE IN OHMS, 1/4W, ±5%
3. ALL CAPACITOR VALUES ARE IN MICROFARADS (UF)
4. ALL INDUCTANCE VALUES ARE IN MICROHENRIES (UH)
5. \* DENOTES COMPONENTS WHICH ARE MECHANICALLY MOUNTED TO THE HEATSINK, AND CALLED OUT ON HEATSINK ASSEMBLY
6. WHEN INSTALLING OR REPLACING Q2 AND Q3 OR Q4 AND Q5, INSTALL OR REPLACE THEM IN MATCHED PAIRS.
7. VENDOR PART NO. CALLOUTS ARE FOR REFERENCE ONLY. COMPONENTS ARE SUPPLIED PER PART NO. IN PARTS LIST
8. DC RESISTANCES OF INDUCTIVE ELEMENTS (CHOKES, COILS, MOTOR WINDINGS, ETC.) ARE LESS THAN 1 OHM.
9. PANEL DECALS ARE INDICATED BY BOLD TYPE IN A BOLD BOX, E.G. **ON/OFF**

HIGHEST REFERENCE DESIGNATION				
C66	CR13	J7	JMPI	L6
P1	Q12	R68	T7	TP4
U3	VRI	E22	RT3	
REFERENCE DESIGNATIONS NOT USED				
C28	C29	CR10	CR11	J1
J2	J3	J4	J5	TP1

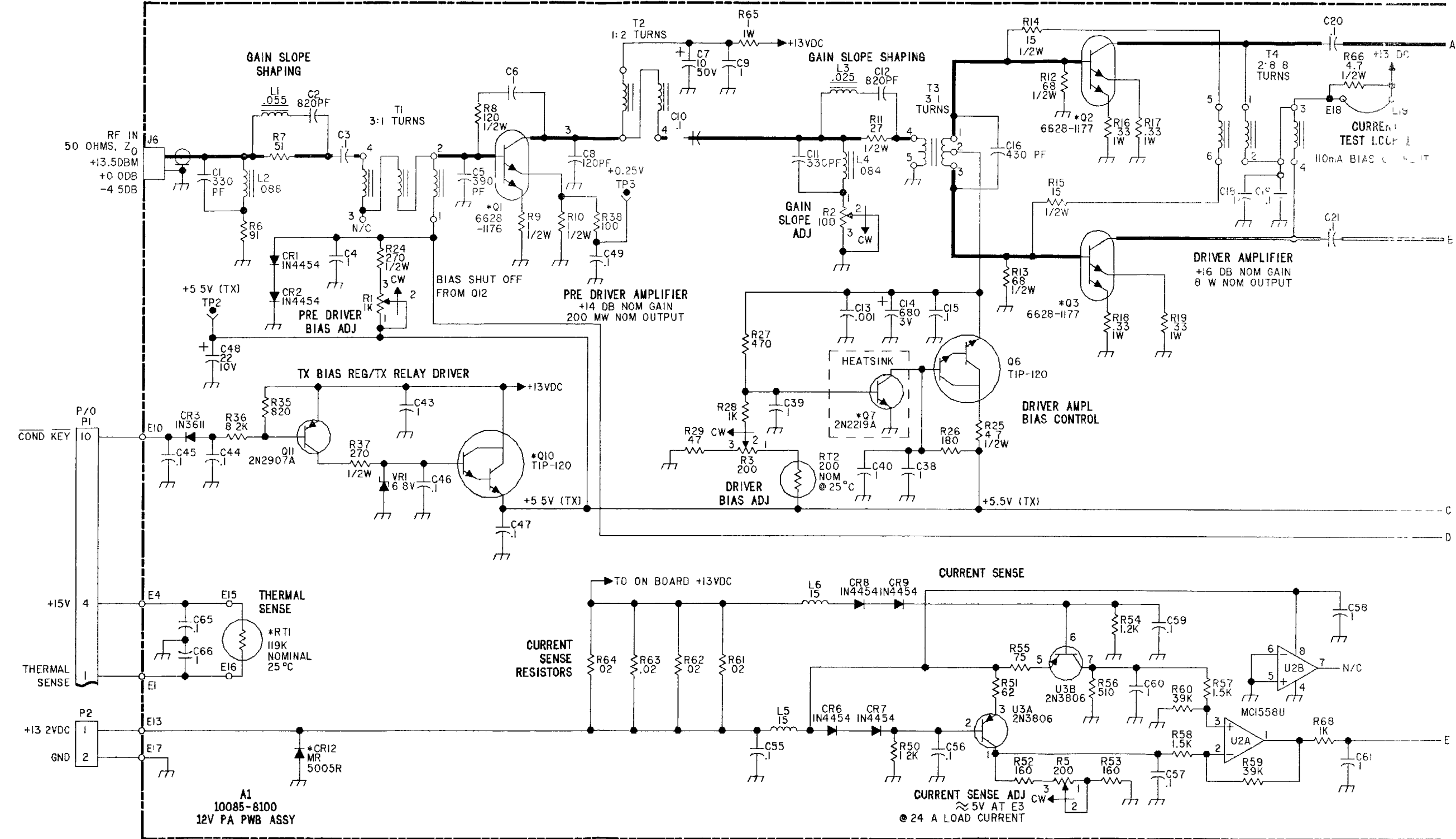

FO-6. POWER AMPLIFIER PWB ASSY, A1A4A1 (Sheet 1 of 2)





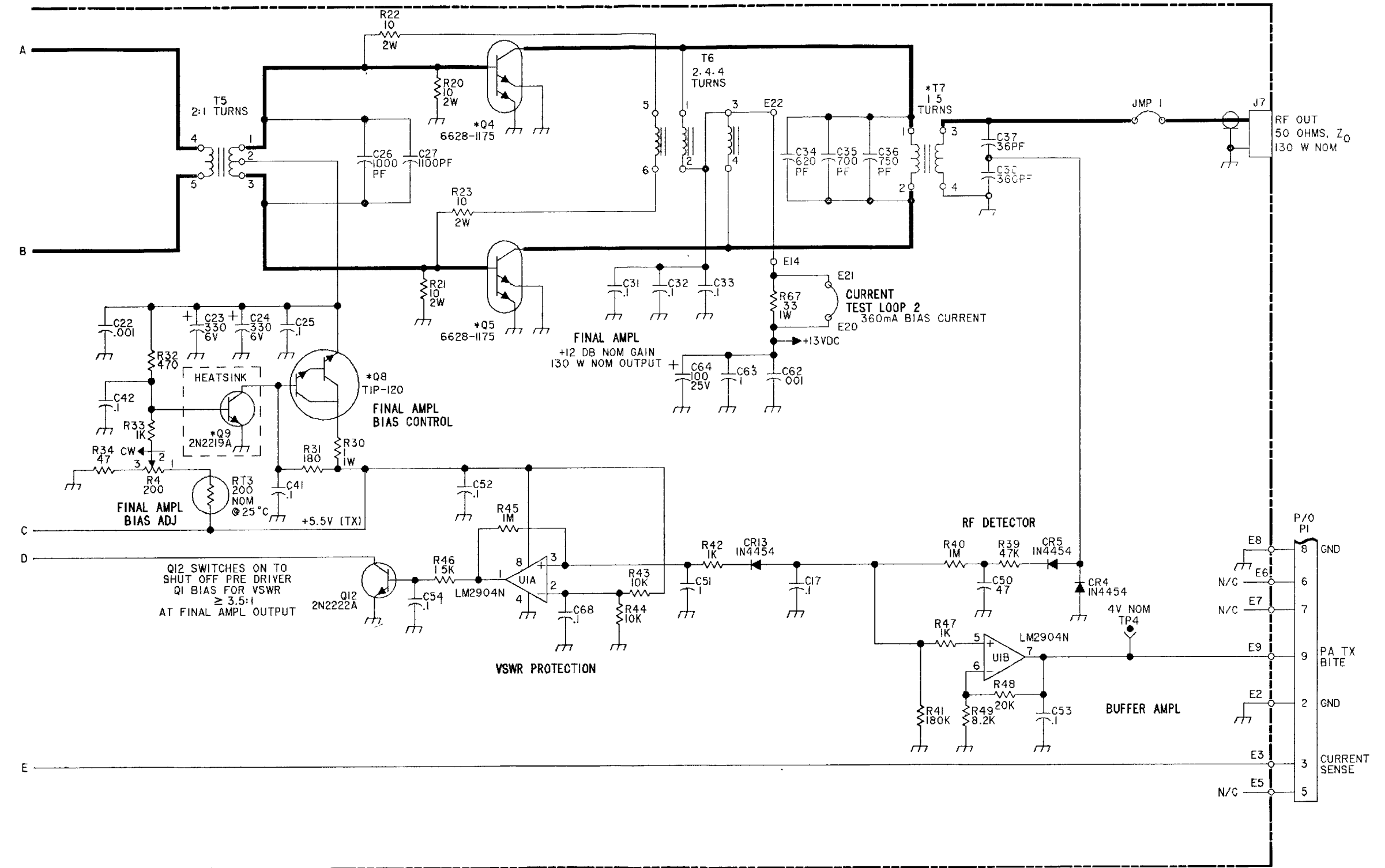

FO-6. POWER AMPLIFIER PWB ASSY, A1A4A1 (Sheet 2 of 2)



NOTE: UNLESS OTHERWISE SPECIFIED:

- PARTIAL REFERENCE DESIGNATIONS ARE SHOWN FOR DETAIL PARTS. PREFIX THESE WITH UNIT NO. AND/OR ASSEMBLY DESIGNATIONS SHOWN ON DRAWING TO OBTAIN COMPLETE DESIGNATIONS.
- ALL RESISTOR VALUES ARE IN OHMS, 1/4W, ±5%
- ALL CAPACITOR VALUES ARE IN PICOFARADS (PF).
- ALL INDUCTANCE VALUES ARE IN MICROHENRIES (UH).
- VENDOR PART NO. CALLOUTS ARE FOR REFERENCE ONLY. COMPONENTS ARE SUPPLIED PER PART NO. IN PARTS LIST.
- DC RESISTANCES OF INDUCTIVE ELEMENTS (CHOKES, COILS, MOTOR WINDINGS, ETC.) ARE LESS THAN 1 OHM.
- PANEL DECALS ARE INDICATED BY BOLD TYPE IN A BOLD BOX, E.G., **ON/OFF**
- ALL RELAYS ARE SHOWN IN THE DE-ENERGIZED STATE.

HIGHEST REFERENCE DESIGNATION					
AR2	C231	CR13	E9	J6	
K14	L48	Q5	R39	RT1	
REFERENCE DESIGNATIONS NOT USED					
C2	C163	C164	C165	C166	
C167	C168	C182	C193	C195	

HIGHEST REFERENCE DESIGNATION				
TI	TP4	UI	Y1	
REFERENCE DESIGNATIONS NOT USED				
C197	C201	C205	C229	L19
L28	L29	L30	L45	R30

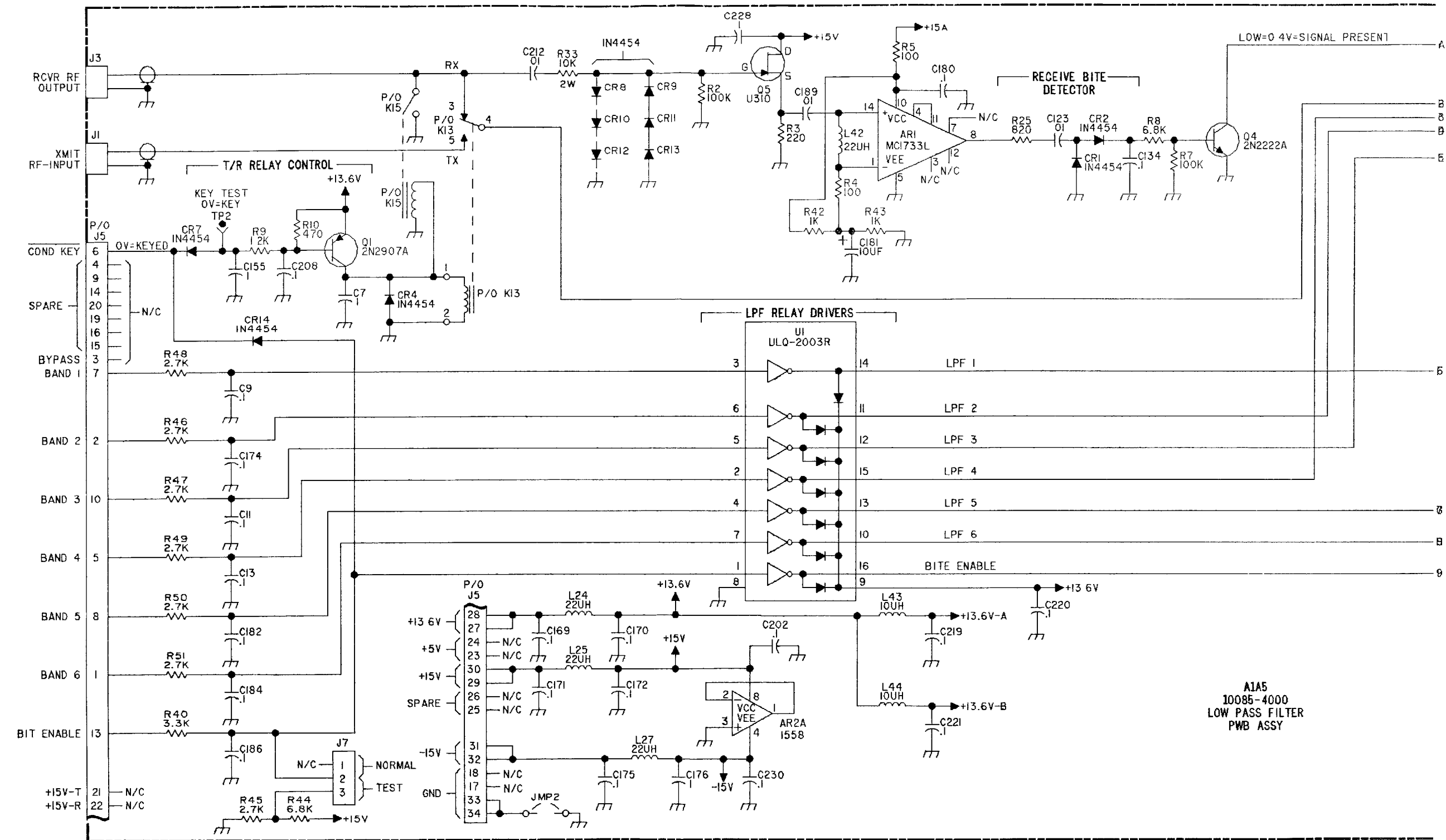

FO-7 LOW PASS FILTER PWB ASSY, A1A5 (Sheet 1 of 4)



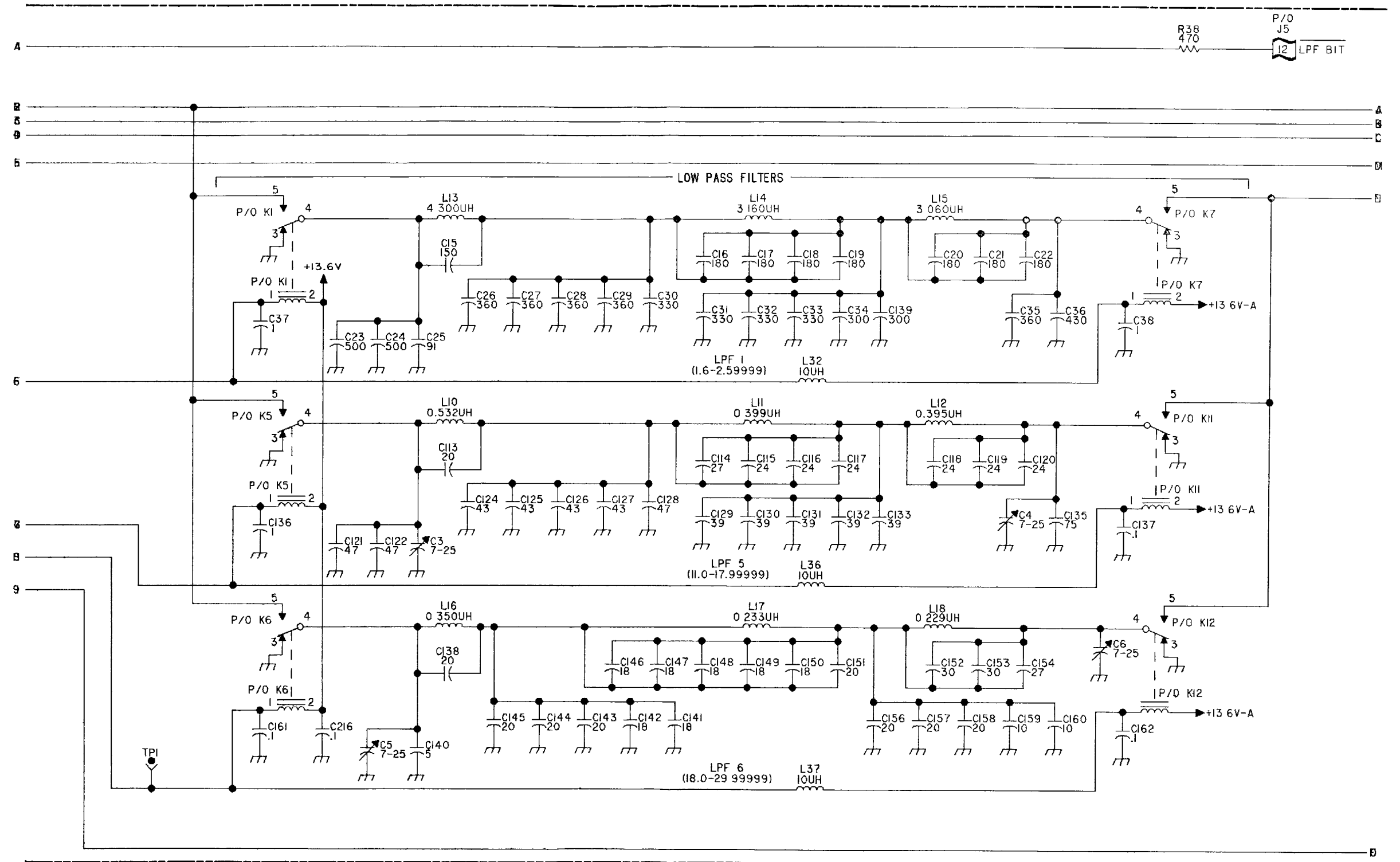

FO-7 LOW PASS FILTER PWB ASSY,  
A1A5 (Sheet 2 of 4)



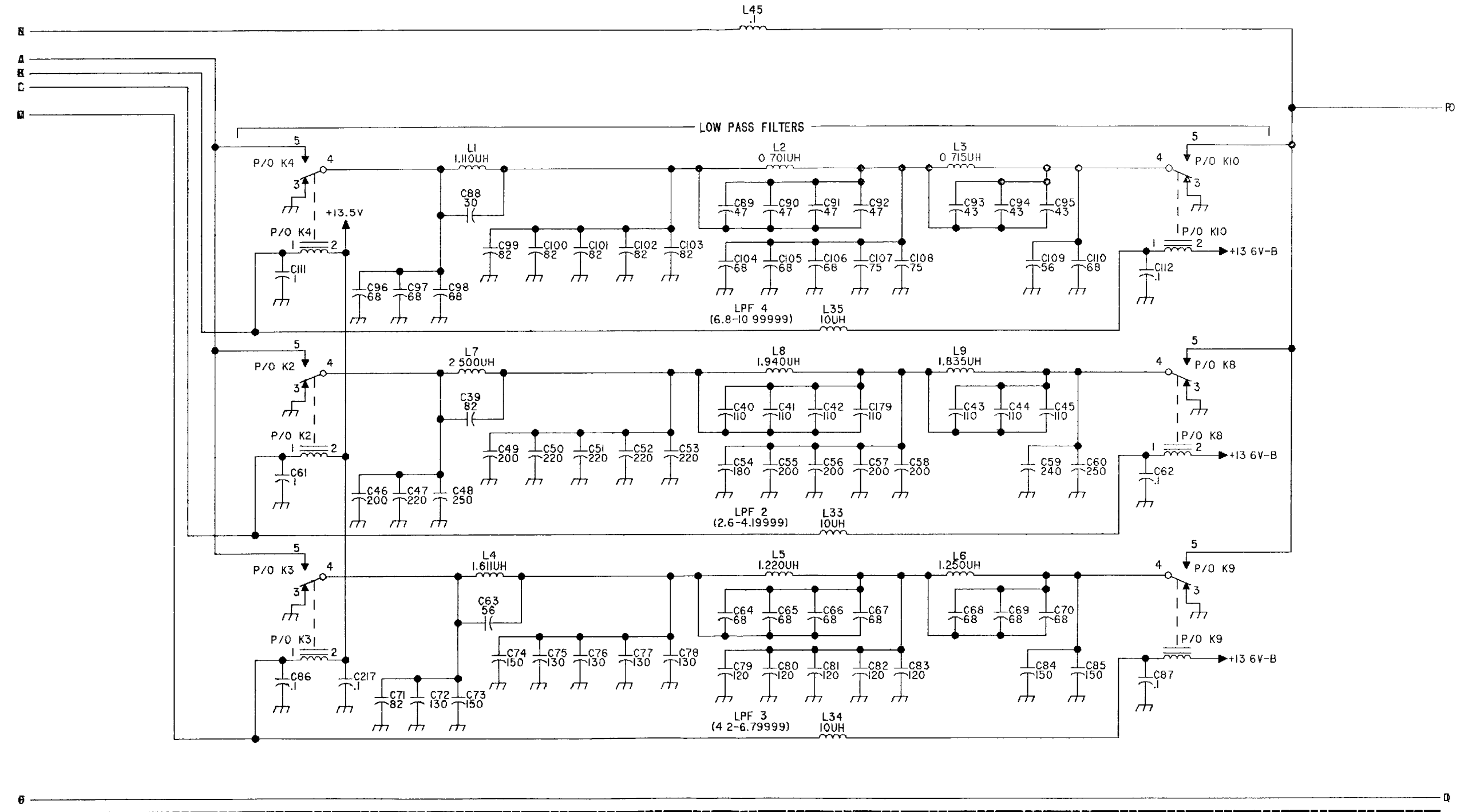

FO-7 LOW PASS FILTER PWB ASSY,  
A1A5 (Sheet 3 of 4)





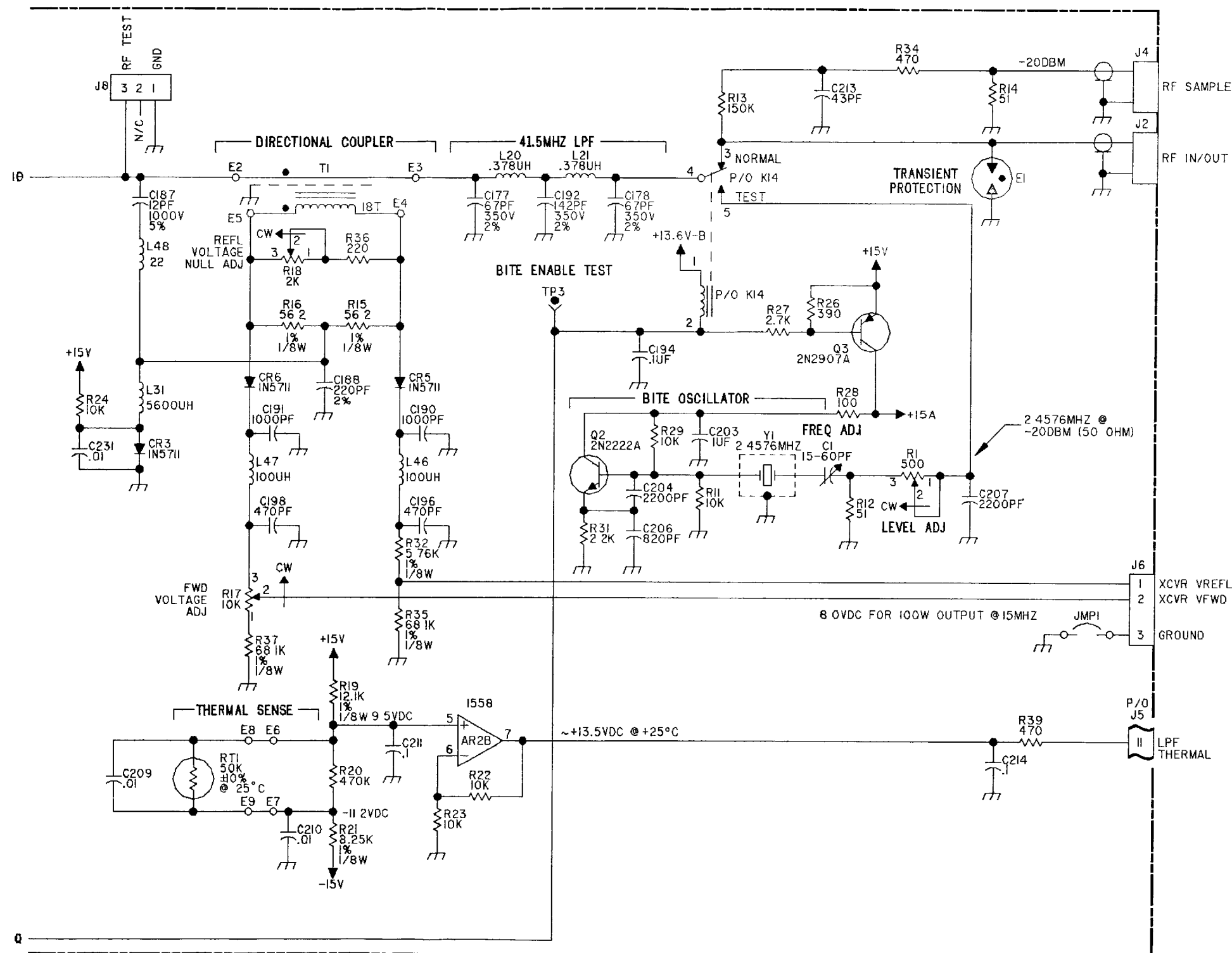

FO-7 LOW PASS FILTER PWB ASSY, A1A5 (Sheet 4 of 4)



NOTE: UNLESS OTHERWISE SPECIFIED:

1. PARTIAL REFERENCE DESIGNATIONS ARE SHOWN FOR DETAIL PARTS. PREFIX THESE WITH UNIT NO. AND/OR ASSEMBLY DESIGNATIONS SHOWN ON DRAWING TO OBTAIN COMPLETE DESIGNATIONS.
2. ALL RESISTOR VALUES ARE IN OHMS, 1/4W, ±5%
3. ALL CAPACITOR VALUES ARE IN MICROFARADS (µF).
4. ALL INDUCTANCE VALUES ARE IN MICROHENRIES (µH)
5. VENDOR PART NO. CALLOUTS ARE FOR REFERENCE ONLY. COMPONENTS ARE SUPPLIED PER PART NO. IN PARTS LIST
6. DC RESISTANCES OF INDUCTIVE ELEMENTS (CHOKES, COILS, MOTOR WINDINGS, ETC.) ARE LESS THAN 1 OHM.
7. PANEL DECALS ARE INDICATED BY BOLD TYPE IN A BOLD BOX, E.G., **ON/OFF**.
8. ALL RELAYS ARE SHOWN IN THE DE-ENERGIZED STATE.

HIGHEST REFERENCE DESIGNATION	
REFERENCE DESIGNATIONS NOT USED	

UNUSED GATES

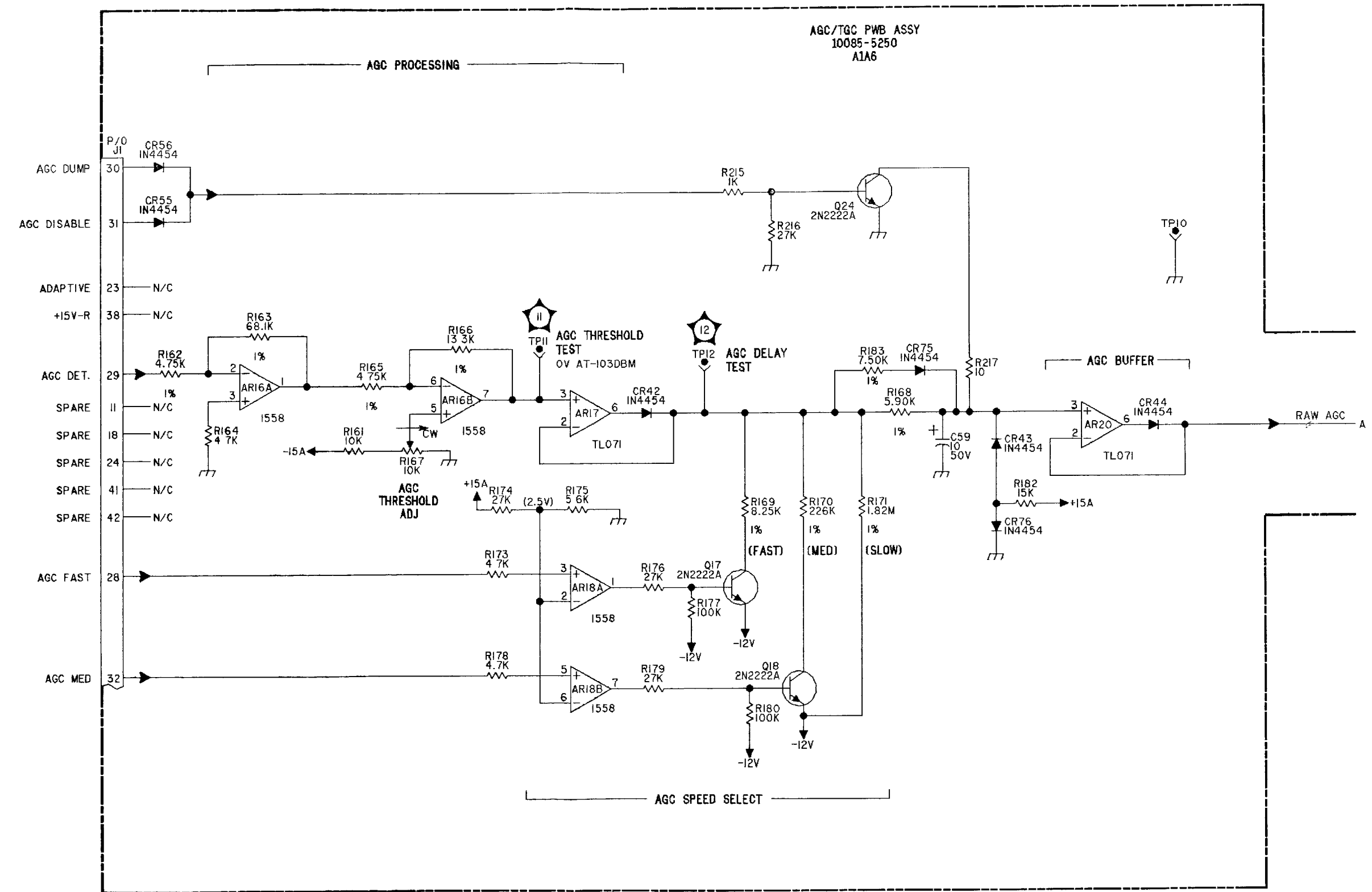
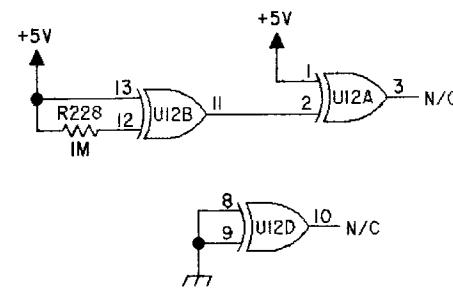
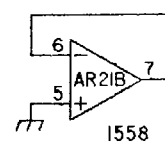



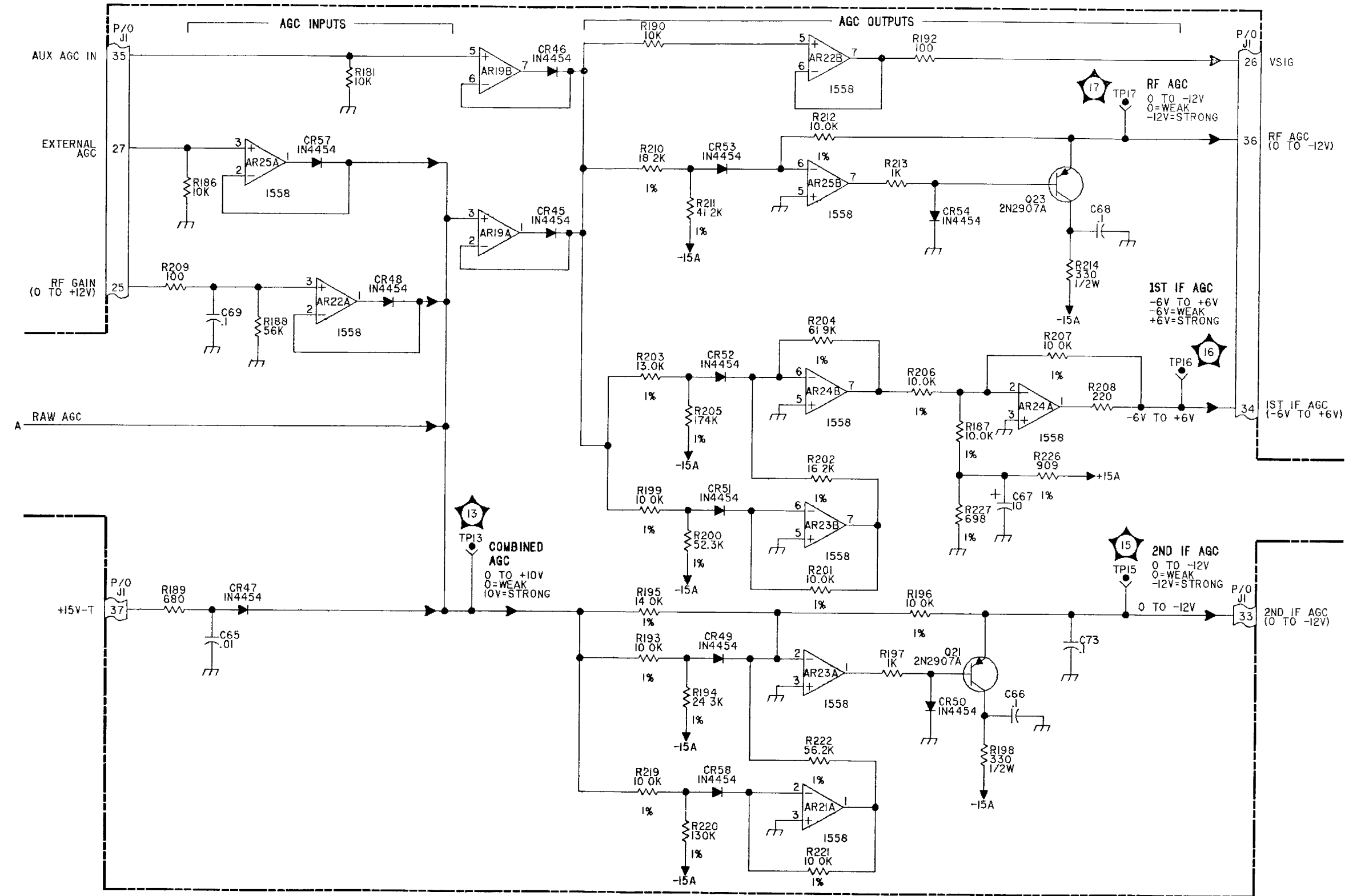

FO-8. AGC/TGC PWB ASSY, A1A6  
(Sheet 2 of 9)



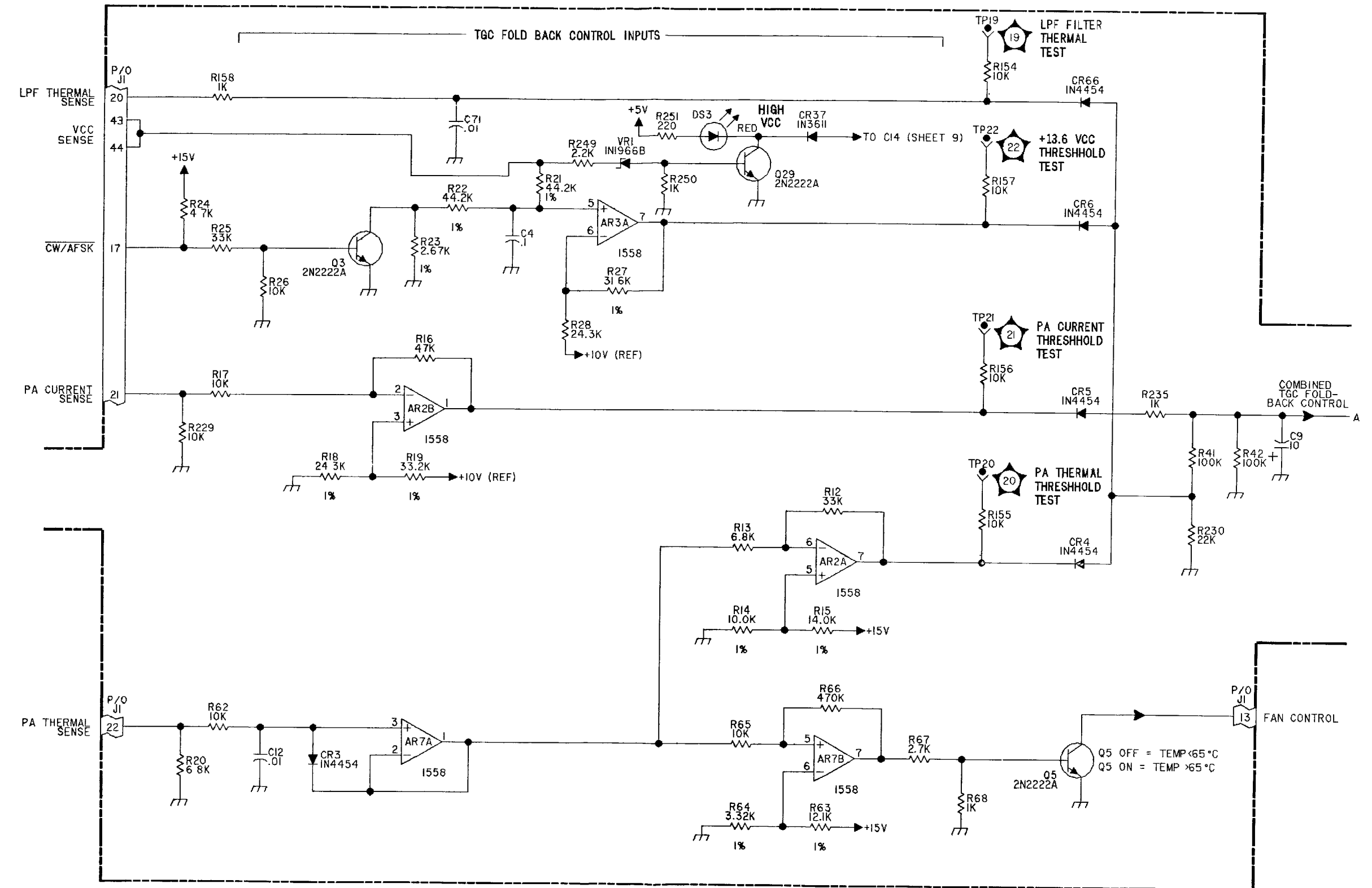

FO-8. AGC/TGC PWB ASSY, A1A6  
(Sheet 3 of 9)





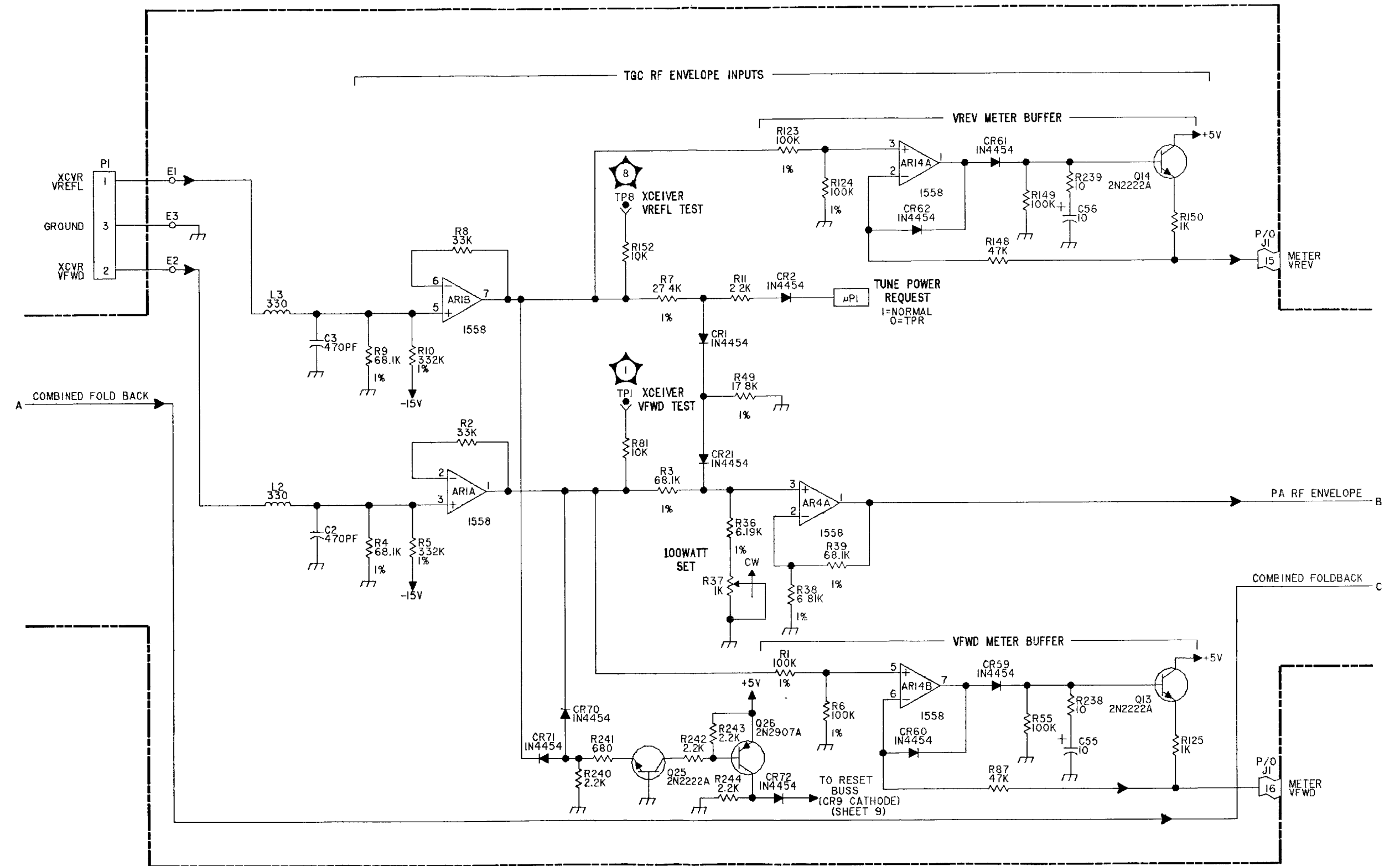

FO-8. AGC/TGC PWB ASSY, A1A6  
(Sheet 4 of 9)



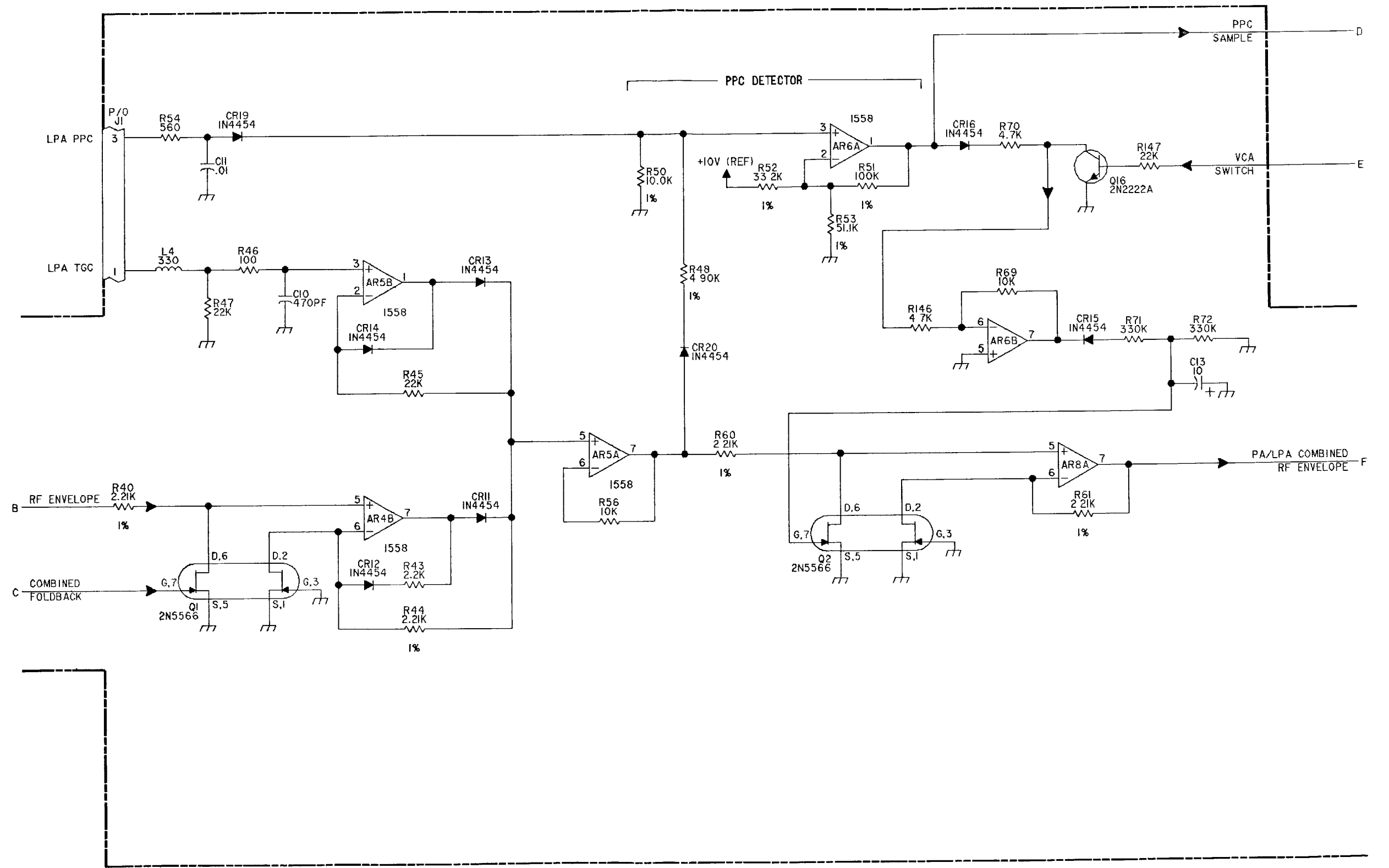

FO-8. AGC/TGC PWB ASSY, A1A6  
(Sheet 5 of 9)



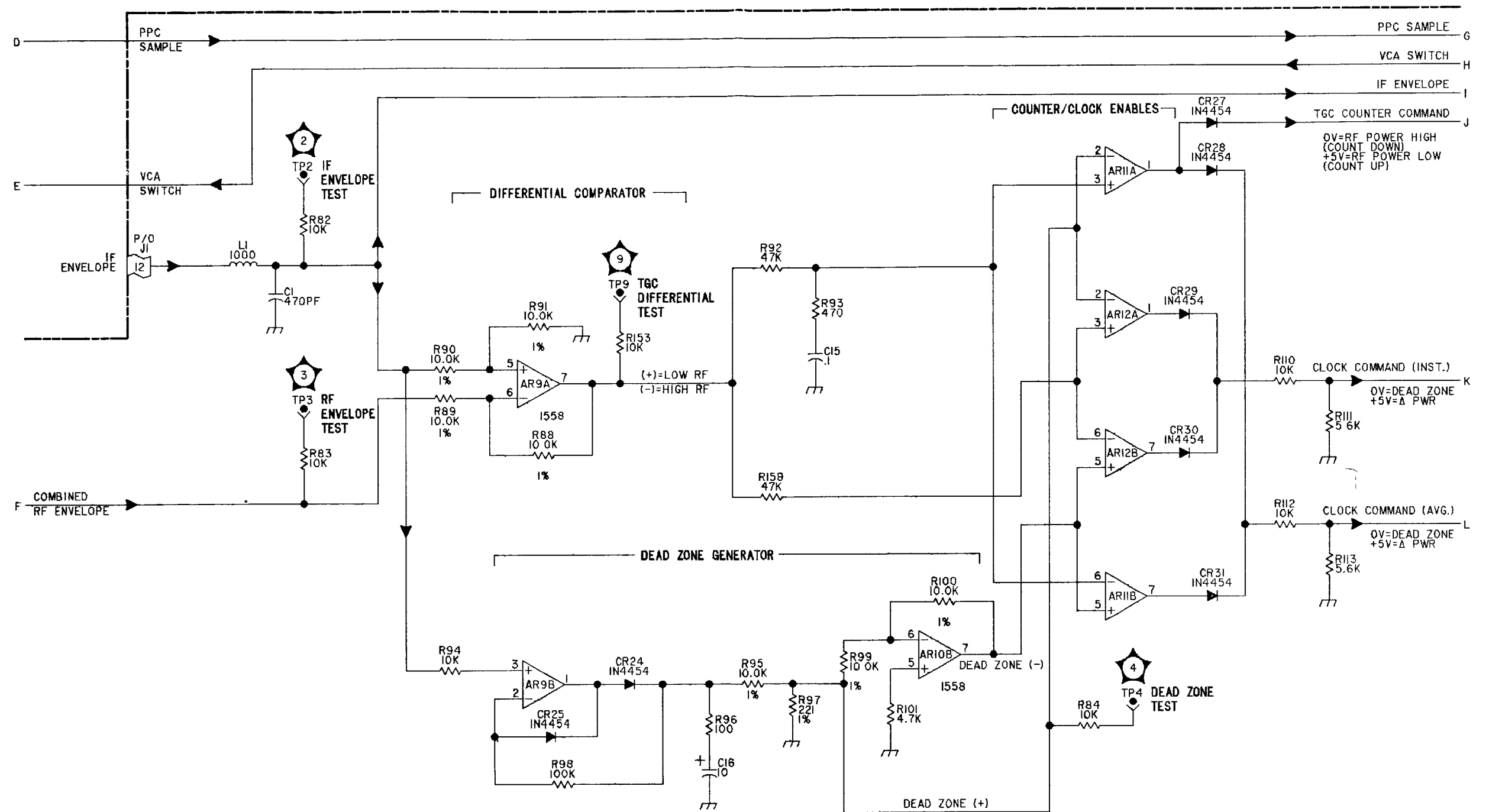



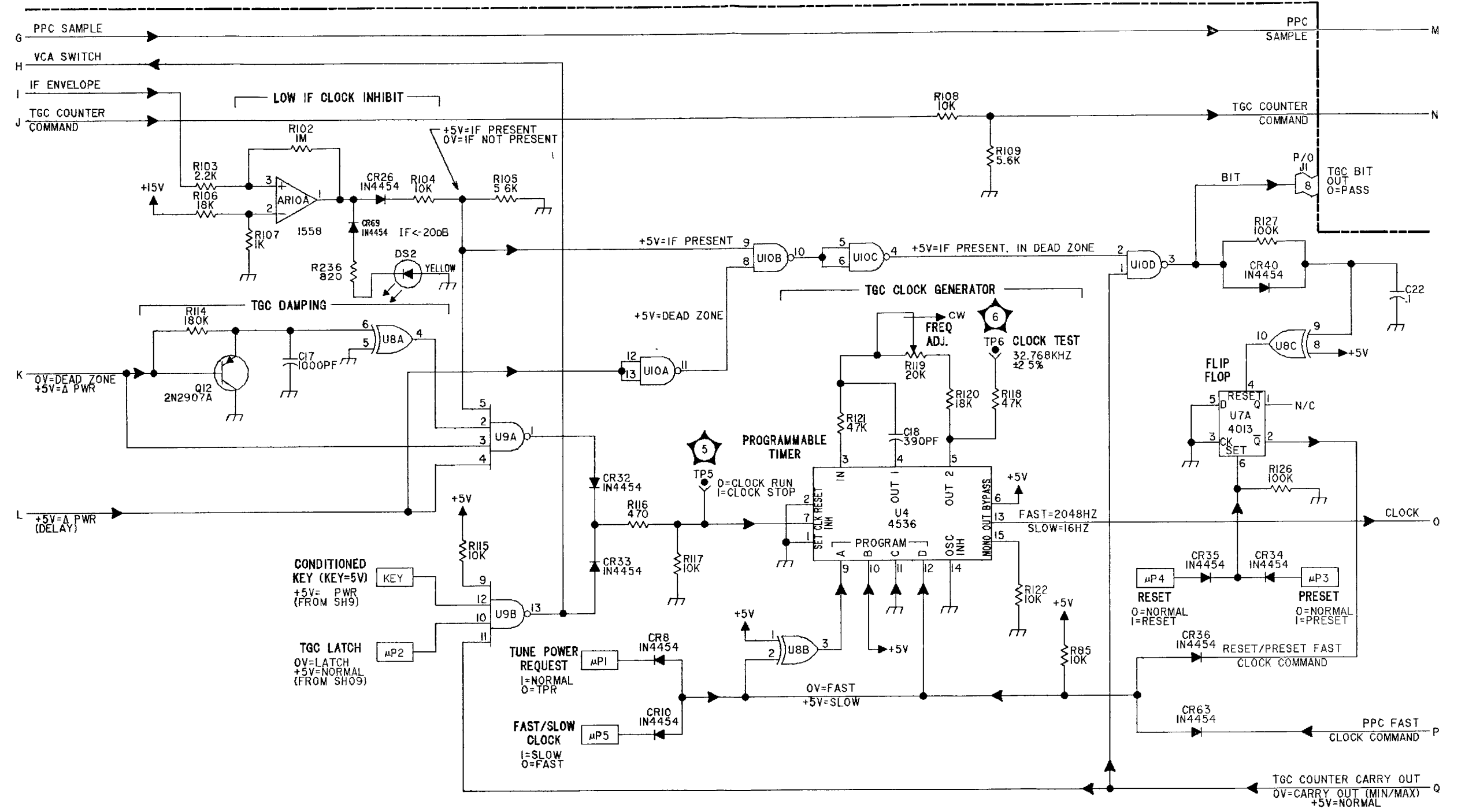

FO-8. AGC/TGC PWB ASSY, A1A6  
(Sheet 7 of 9)





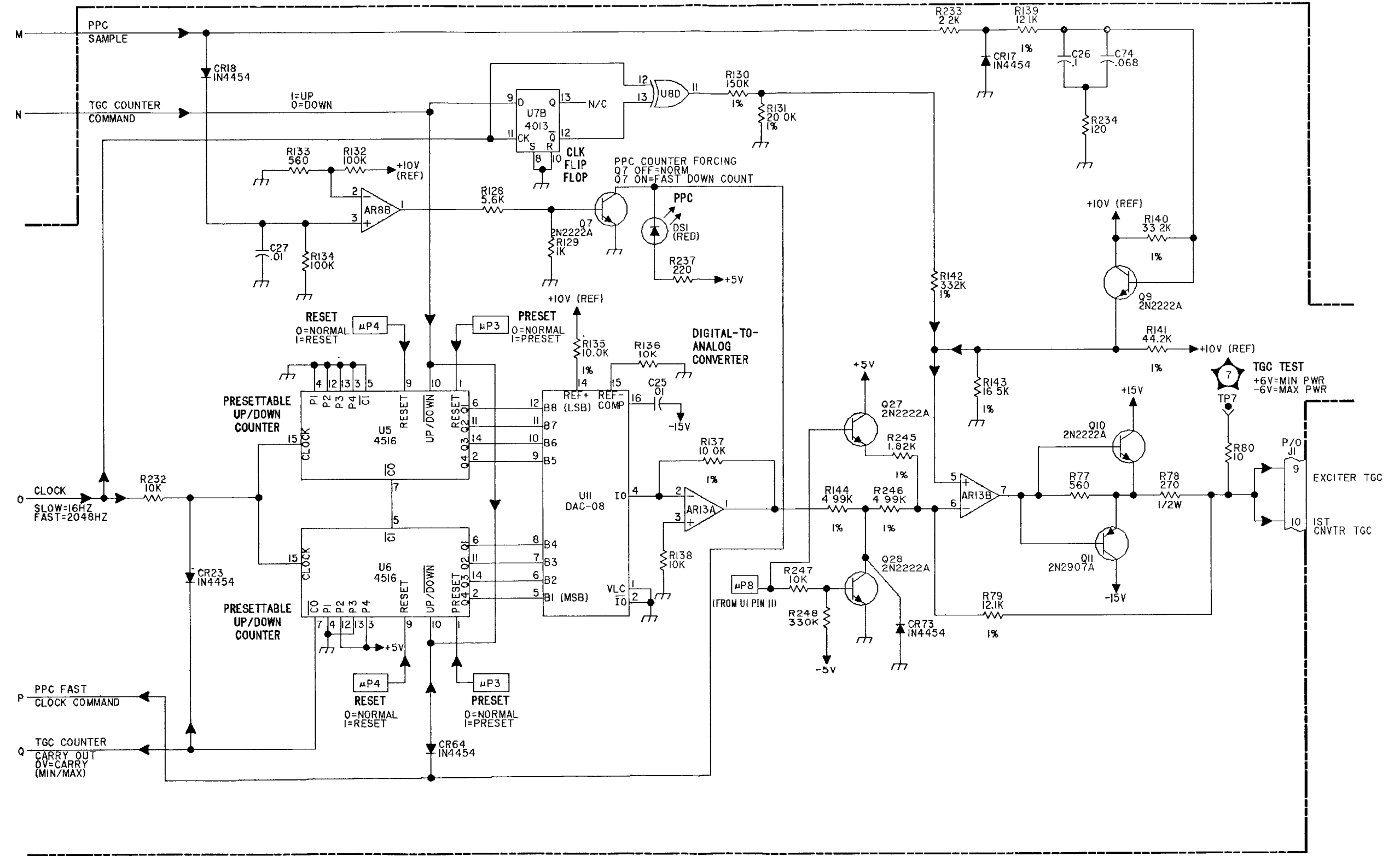

FO-8. AGC/TGC PWB ASSY, A1A6  
(Sheet 8 of 9)



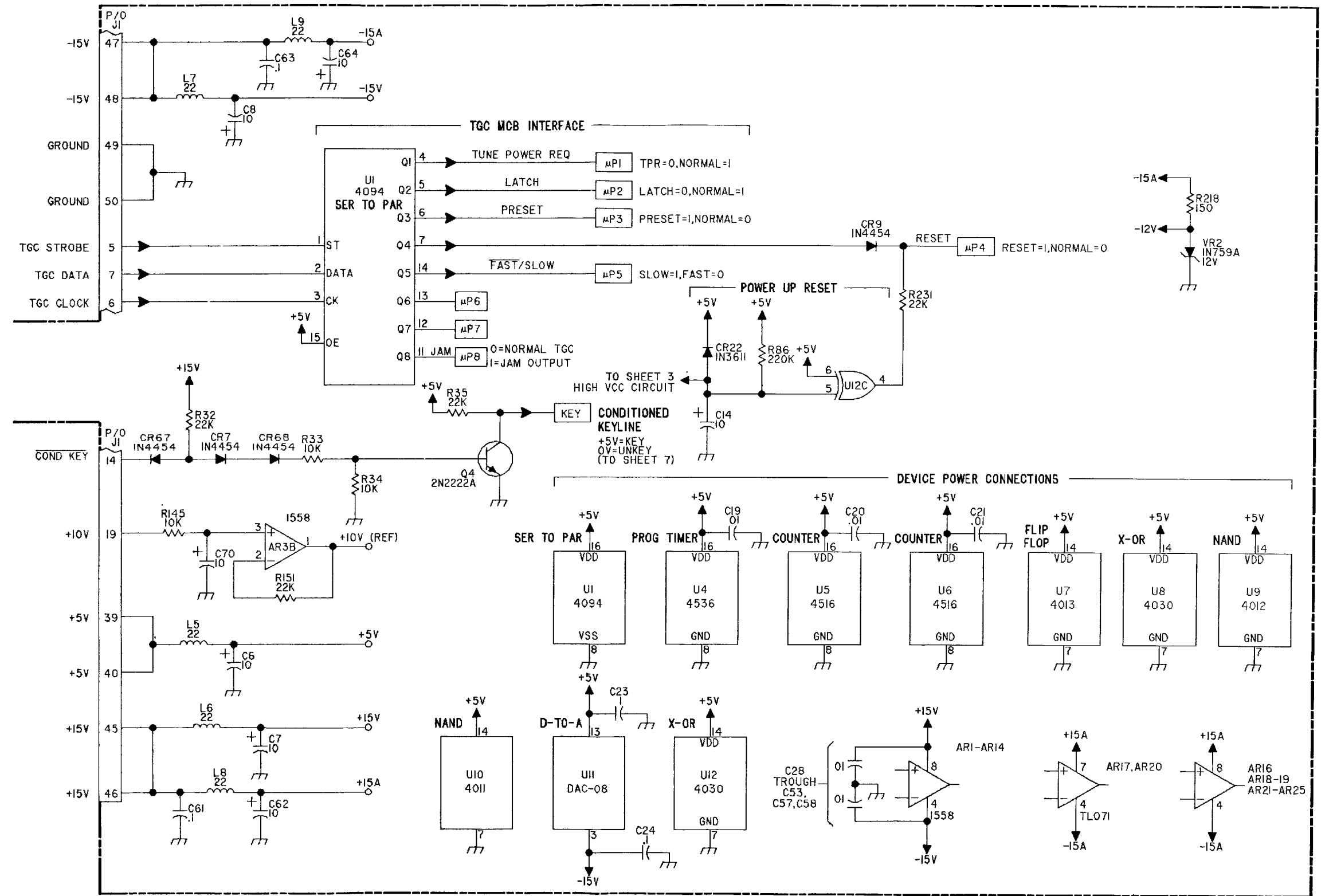

FO-8. AGC/TGC PWB ASSY, A1A6  
(Sheet 9 of 9)



NOTE UNLESS OTHERWISE SPECIFIED:

1. PARTIAL REFERENCE DESIGNATIONS ARE SHOWN FOR DETAIL PARTS. PREFIX THESE WITH UNIT NO. AND/OR ASSEMBLY DESIGNATIONS SHOWN ON DRAWING TO OBTAIN COMPLETE DESIGNATIONS.
2. ALL RESISTOR VALUES ARE IN OHMS, 1/4W, ±5%.
3. ALL CAPACITOR VALUES ARE IN MICROFARADS (UF).
4. ALL INDUCTANCE VALUES ARE IN MICROHENRIES (UH).
5. VENDOR PART NO. CALLOUTS ARE FOR REFERENCE ONLY. COMPONENTS ARE SUPPLIED PER PART NO. IN PARTS LIST.
6. DC RESISTANCES OF INDUCTIVE ELEMENTS (CHOKES, COILS, MOTOR WINDINGS, ETC.) ARE LESS THAN 1 OHM.
7. PANEL DECALS ARE INDICATED BY BOLD TYPE IN A BOLD BOX, E.G., **ON/OFF**.
8. ALL RELAYS ARE SHOWN IN THE DE-ENERGIZED STATE.
9. ALL AMPLIFIERS ARE DUAL 1558.
10.  INDICATES PI CONNECTION AT PWB.

HIGHEST REFERENCE DESIGNATION			
REFERENCE DESIGNATIONS NOT USED			

UNUSED GATES

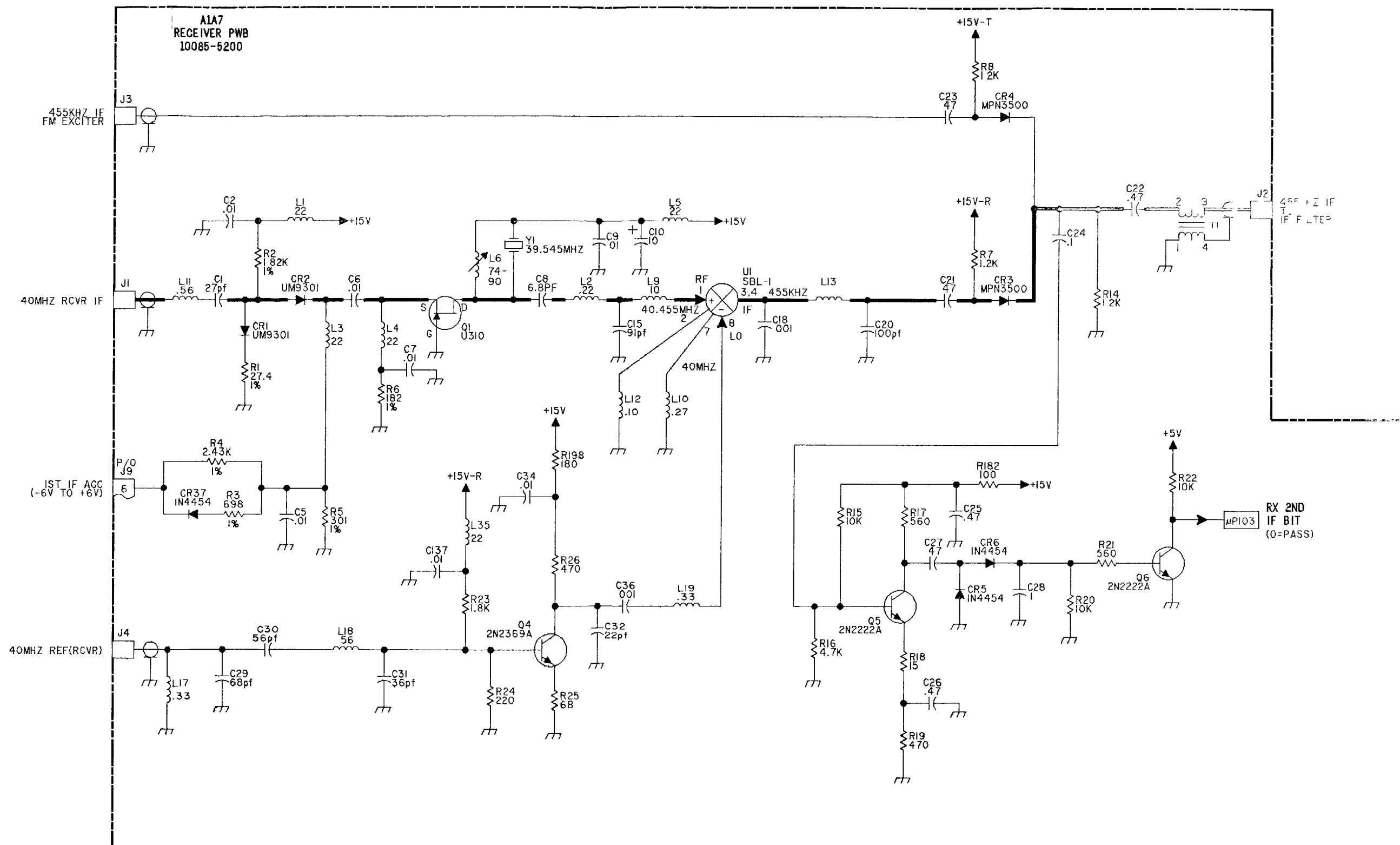
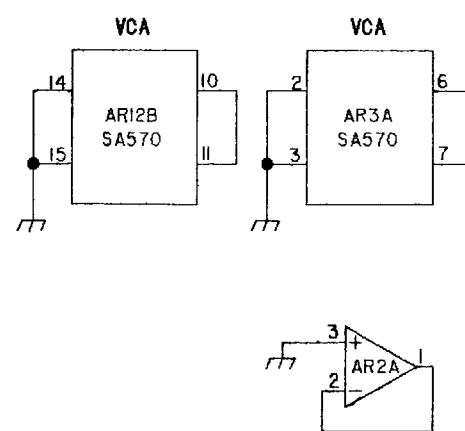

FO-9. RECEIVER PWB ASSY, A1A7 (Sheet 1 of 8)



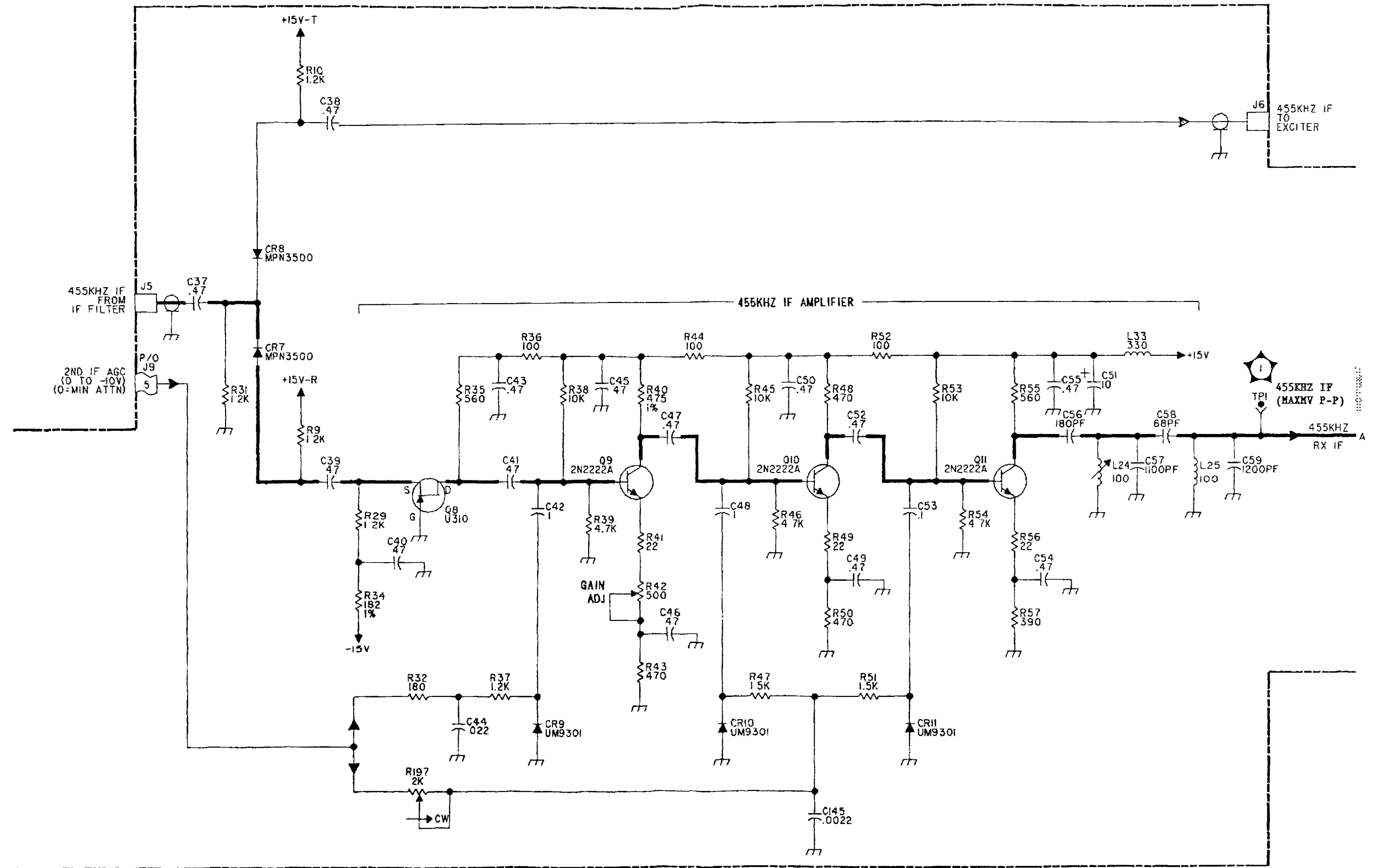

F9504417





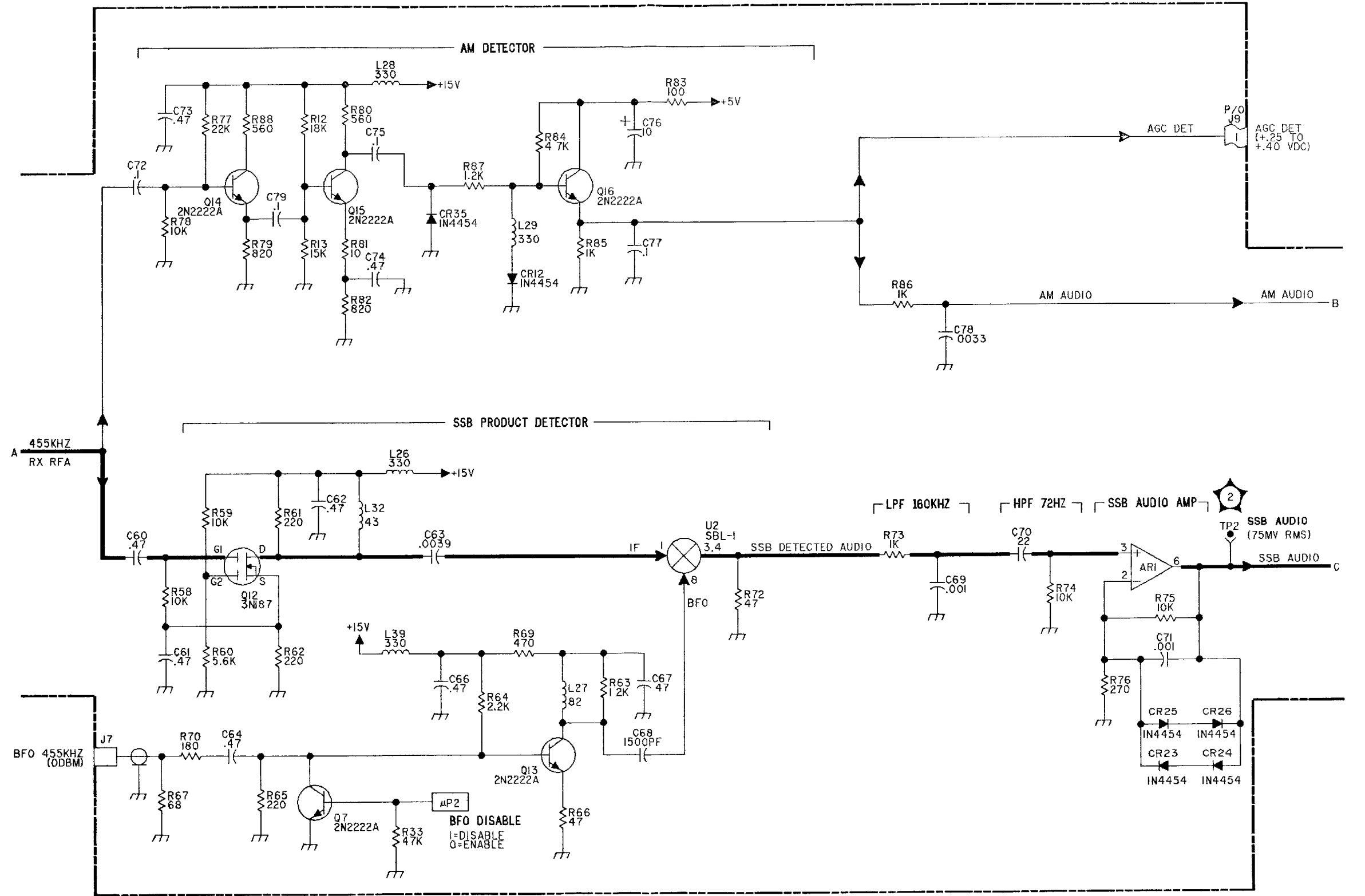

FO-9. RECEIVER PWB ASSY, A1A7  
(Sheet 3 of 8)



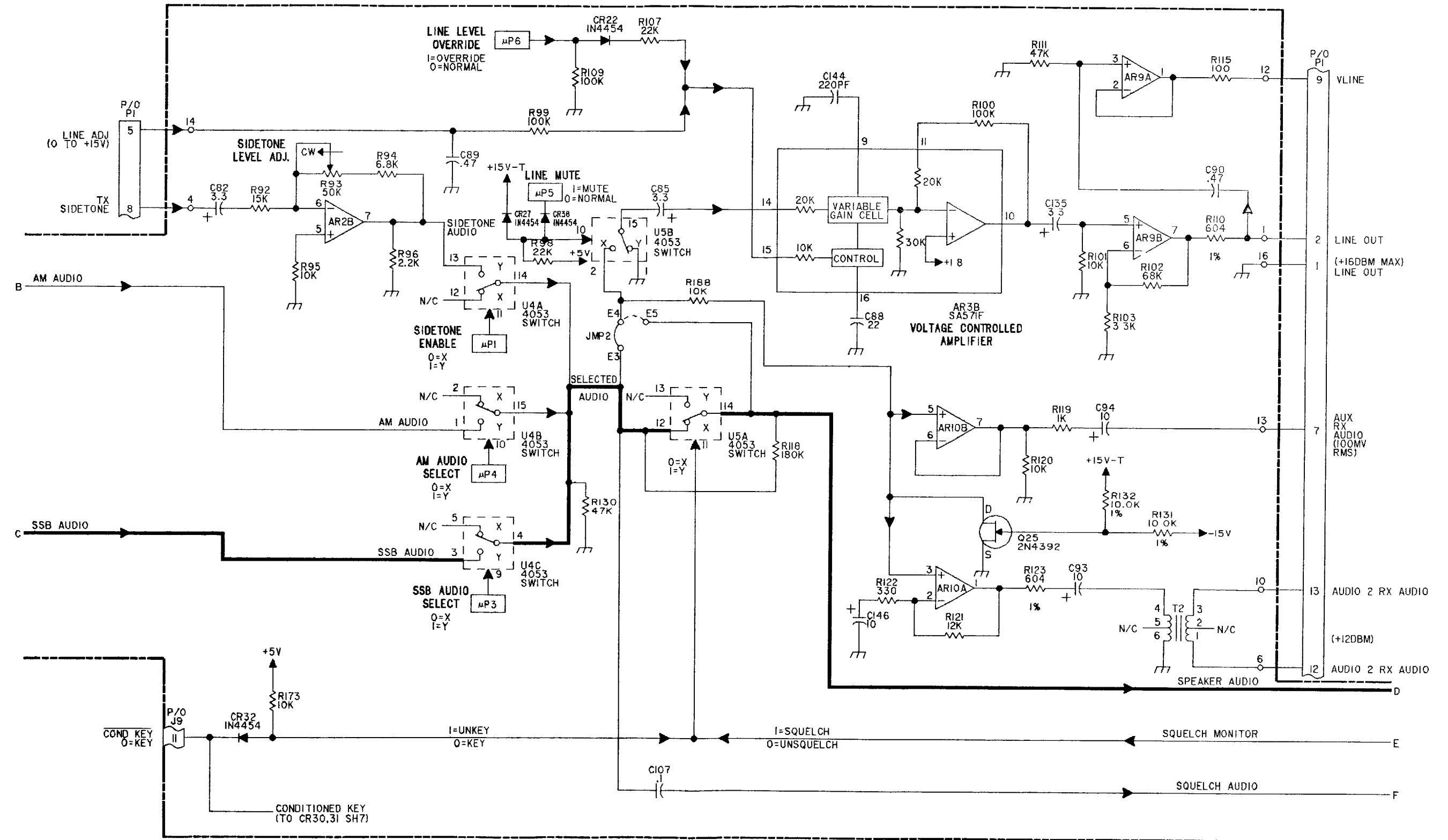

FO-9. RECEIVER PWB ASSY, A1A7  
(Sheet 4 of 8)



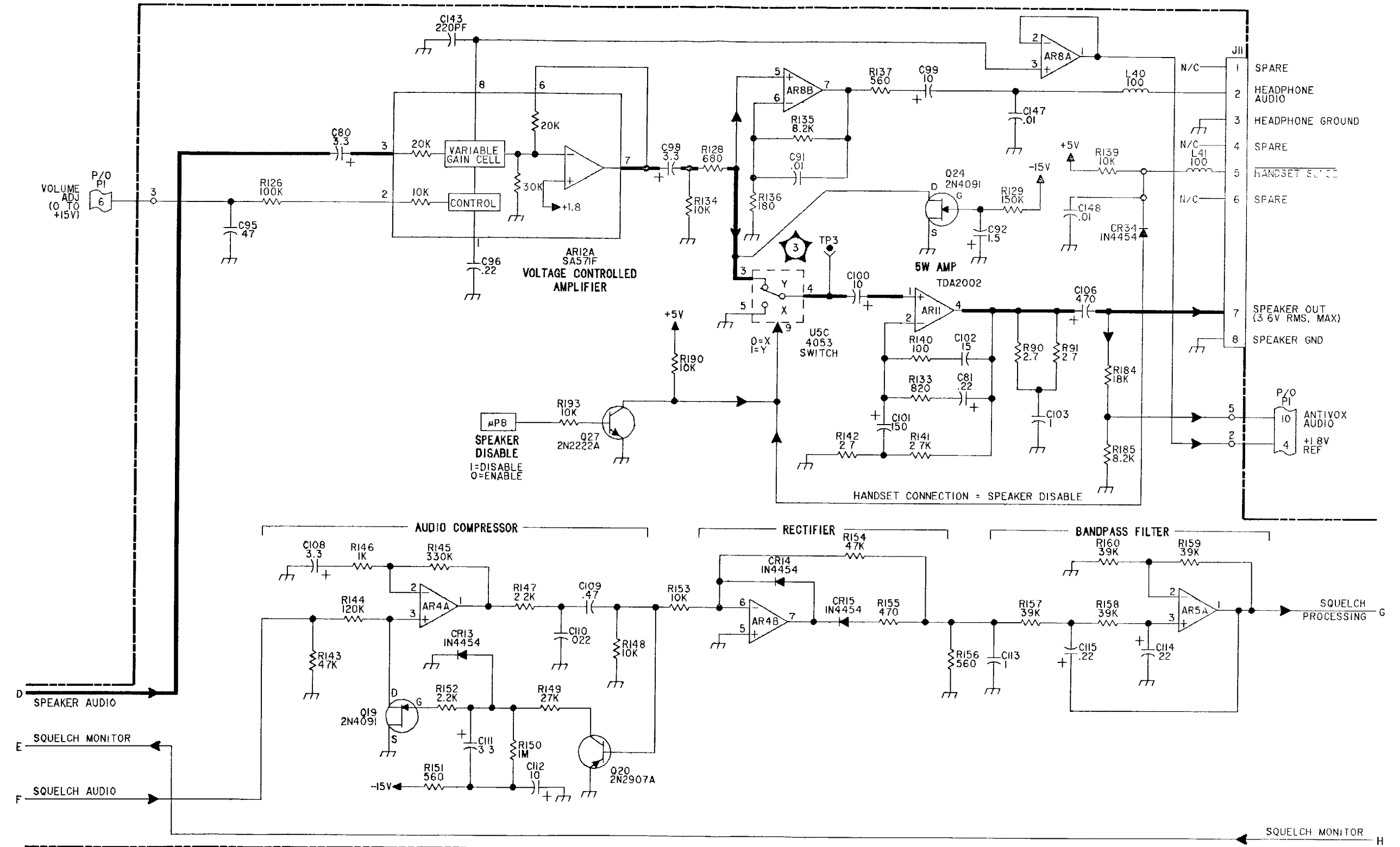

FO-9. RECEIVER PWB ASSY, A1A7  
(Sheet 5 of 8)



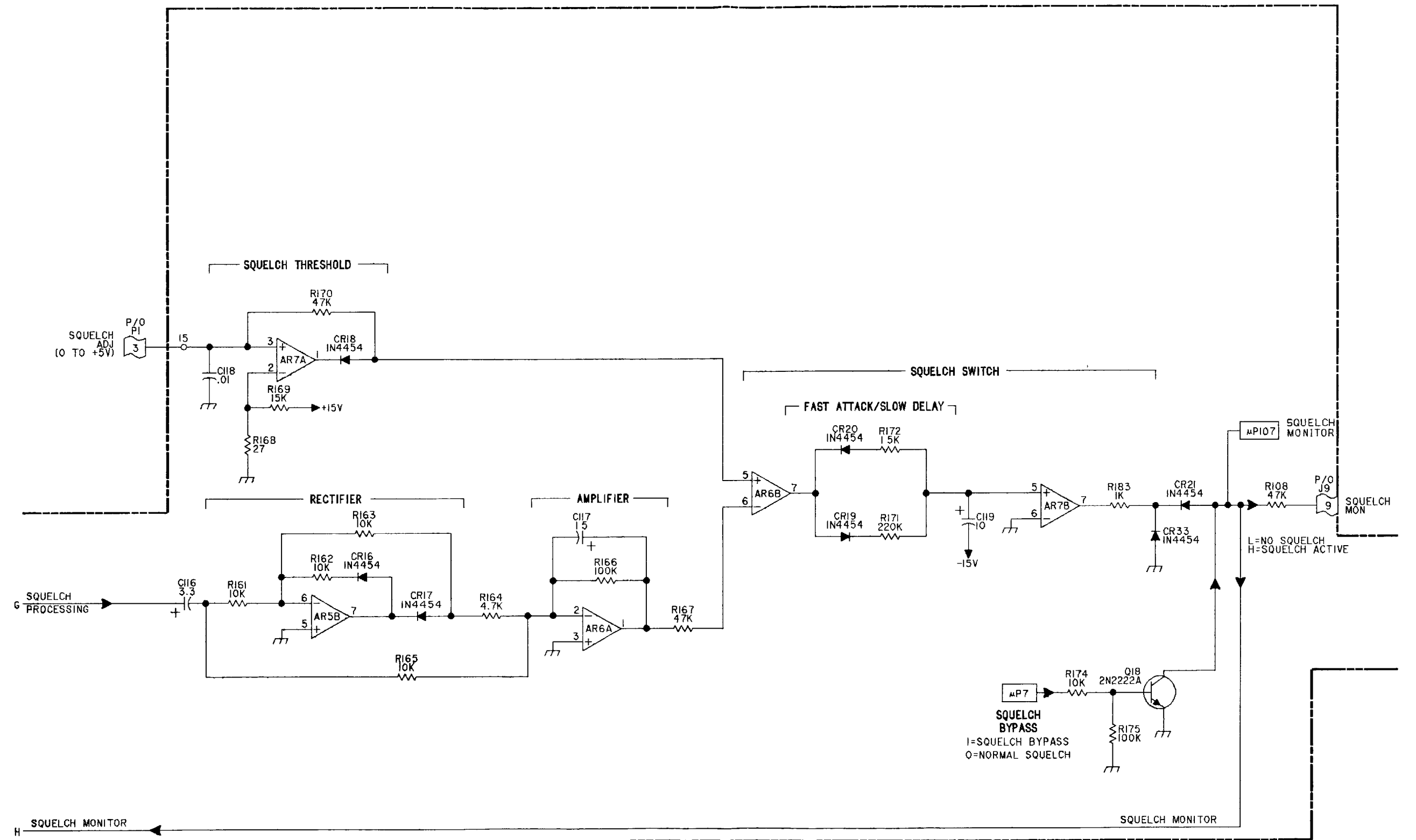

FO-9. RECEIVER PWB ASSY, A1A7  
 (Sheet 6 of 8)





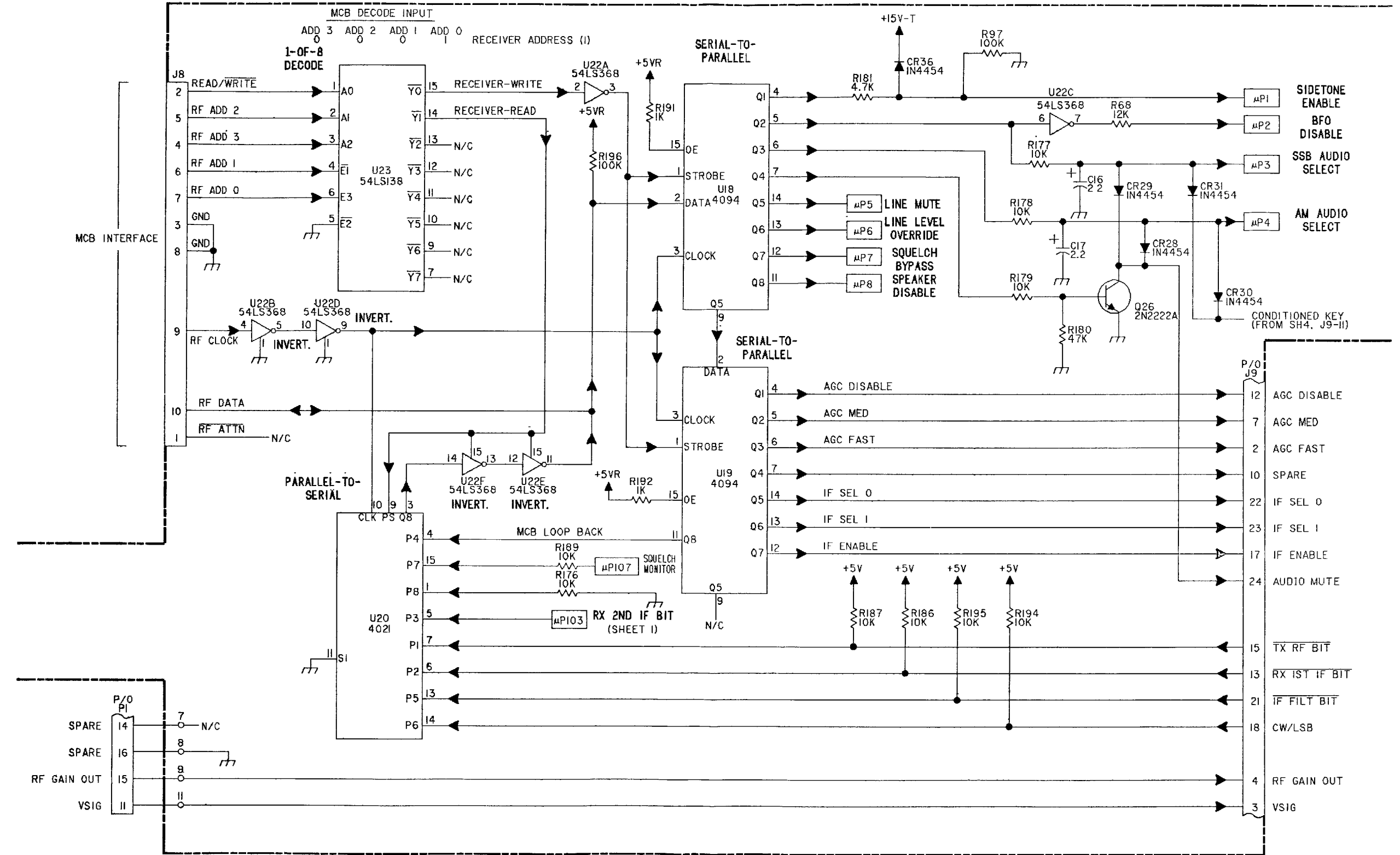

FO-9. RECEIVER PWB ASSY, A1A7  
(Sheet 7 of 8)



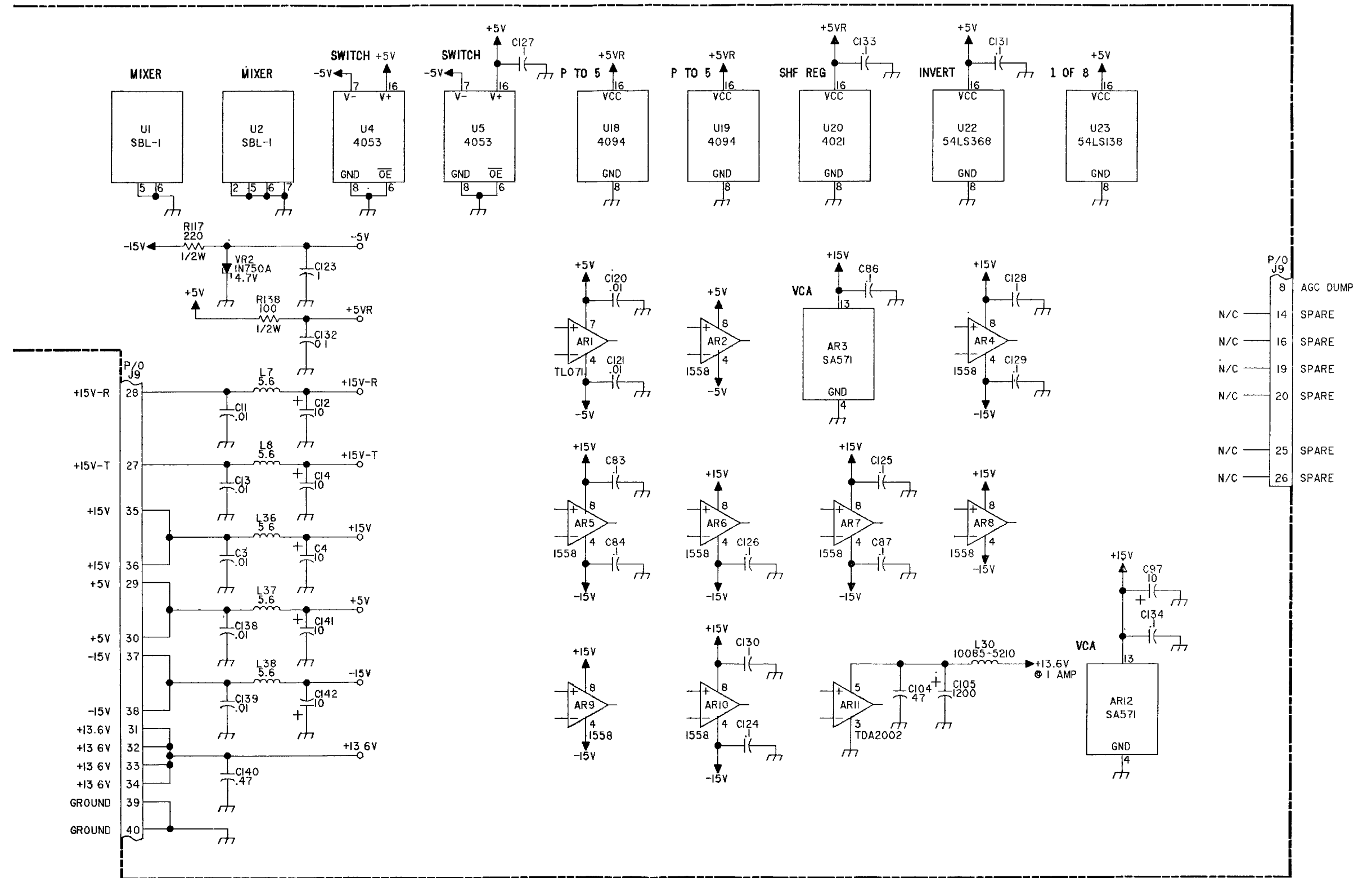

FO-9. RECEIVER PWB ASSY, A1A7  
(Sheet 8 of 8)



NOTE UNLESS OTHERWISE SPECIFIED

1. PARTIAL REFERENCE DESIGNATIONS ARE SHOWN FOR DETAIL PARTS. PREFIX THESE WITH UNIT NO. AND/OR ASSEMBLY DESIGNATIONS SHOWN ON DRAWING TO OBTAIN COMPLETE DESIGNATIONS.
2. ALL RESISTOR VALUES ARE IN OHMS. 1/4W. ±5%
3. ALL CAPACITOR VALUES ARE IN MICROFARADS (UF).
4. ALL INDUCTANCE VALUES ARE IN MICROHENRIES (UH).
5. VENDOR PART NO. CALLOUTS ARE FOR REFERENCE ONLY. COMPONENTS ARE SUPPLIED PER PART NO. IN PARTS LIST
6. DC RESISTANCES OF INDUCTIVE ELEMENTS (CHOKES, COILS, MOTOR WINDINGS, ETC.) ARE LESS THAN 1 OHM.
7. PANEL DECALS ARE INDICATED BY BOLD TYPE IN A BOLD BOX, E.G. **ON/OFF**.
8. ALL RELAYS ARE SHOWN IN THE DE-ENERGIZED STATE.

HIGHEST REFERENCE DESIGNATION			
REFERENCE DESIGNATIONS NOT USED			

UNUSED DEVICES

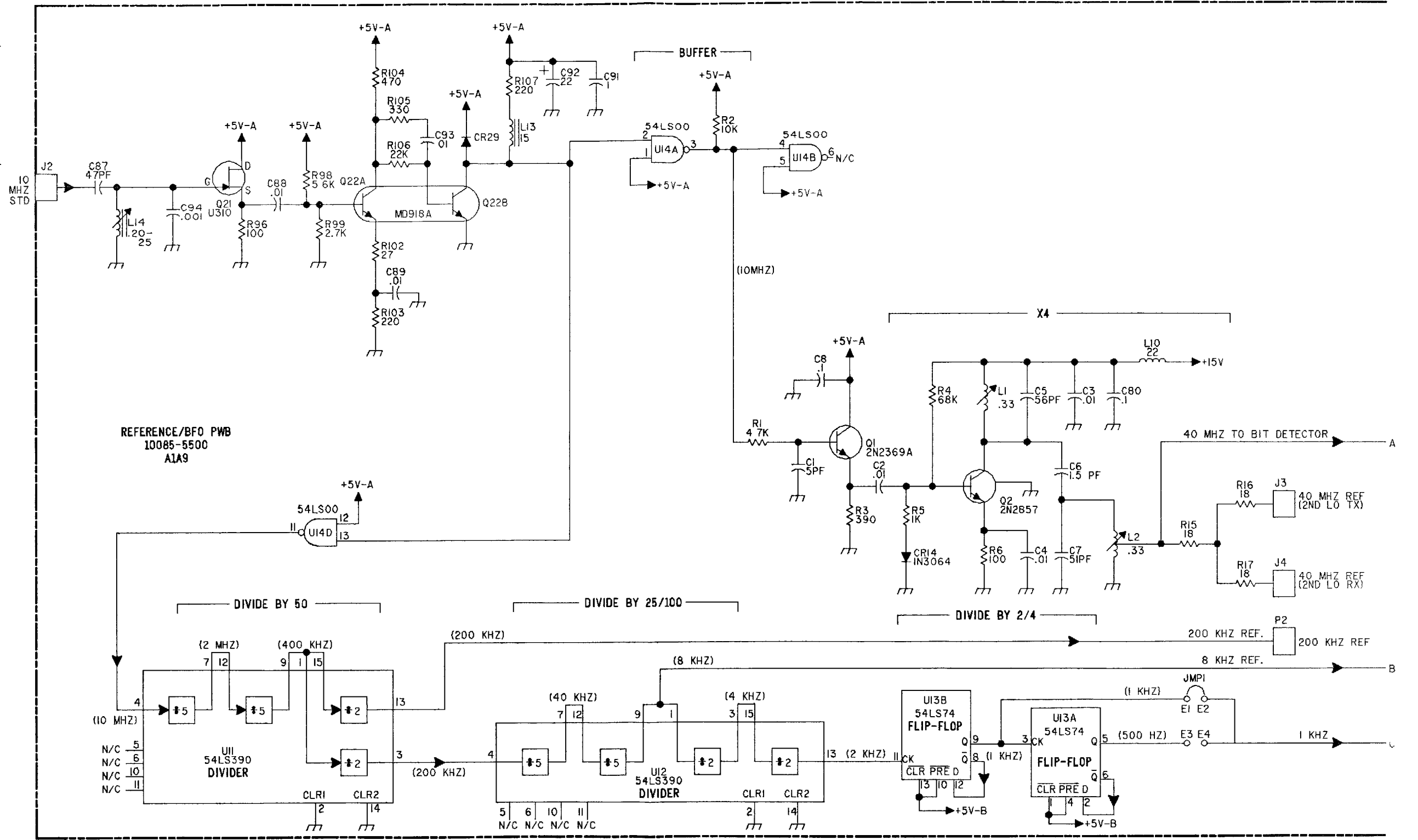
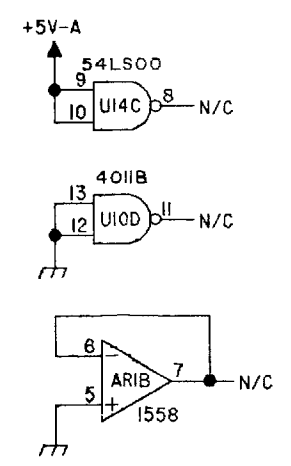

FO-10. REF/BFO PWB ASSY, A1A9  
(Sheet 1 of 6)



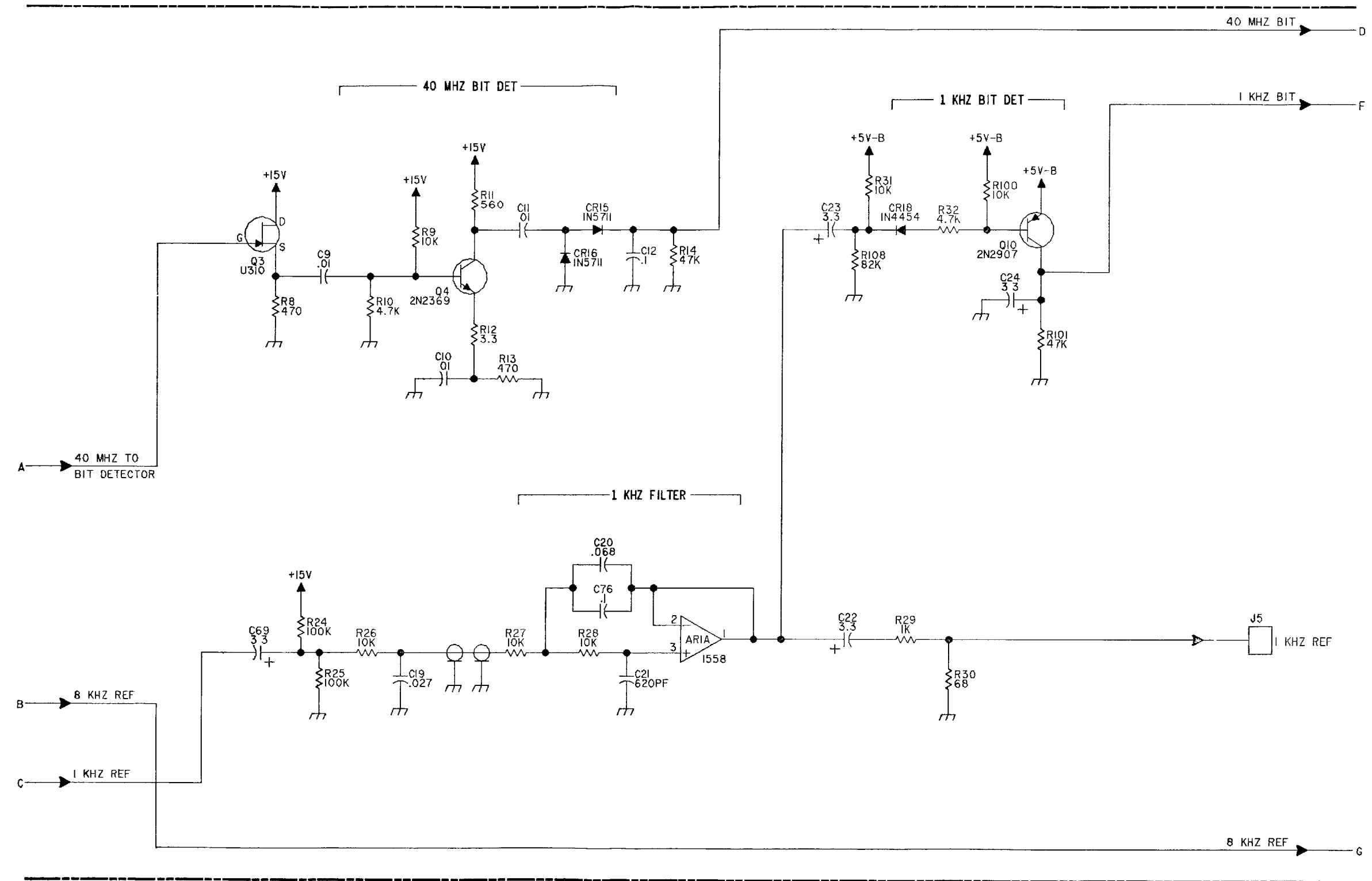

FO-10. REF/BFO PWB ASSY, A1A9  
(Sheet 2 of 6)

FP-105/(FP-106 Blank)





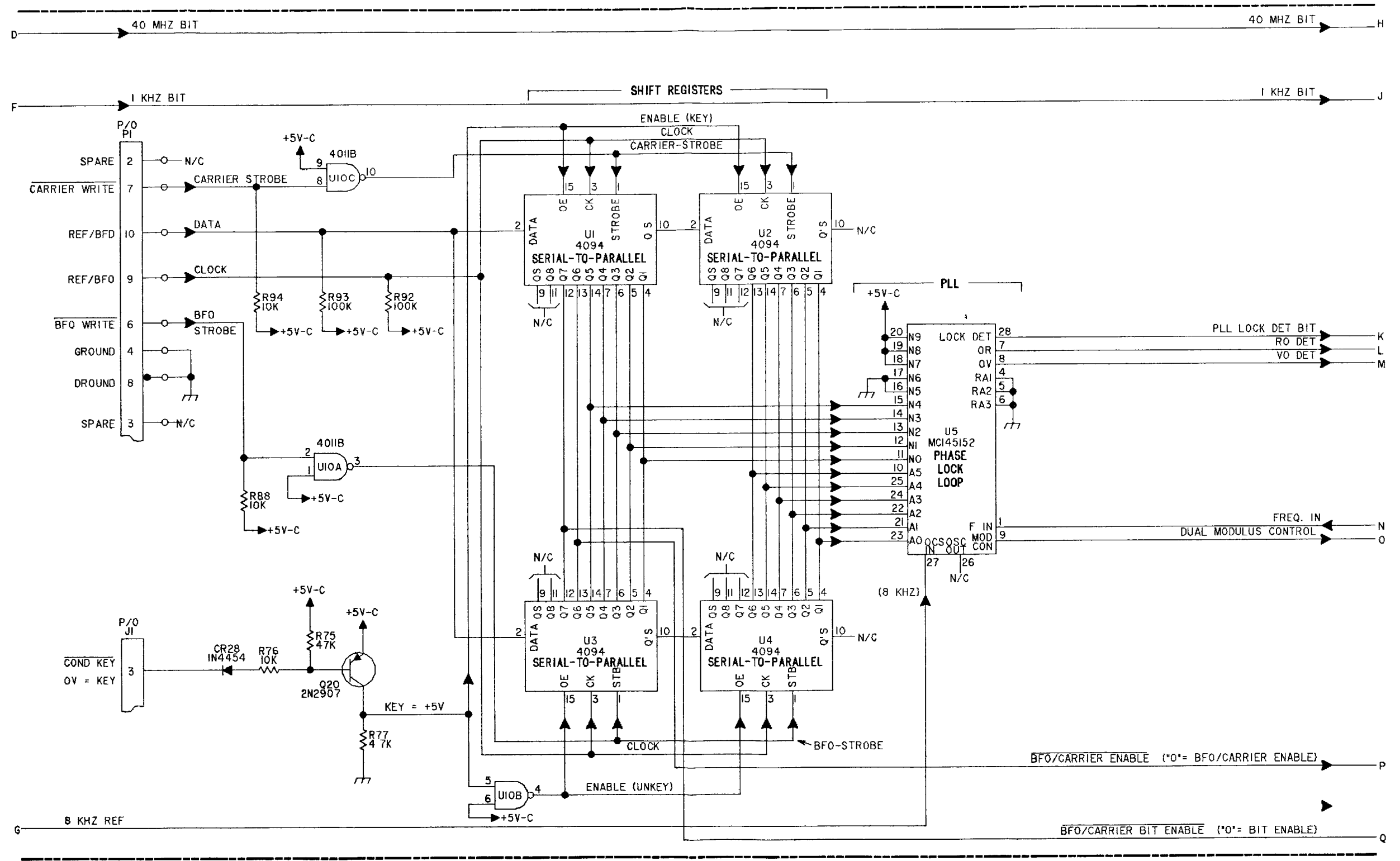

FO-10. REF/BFO PWB ASSY, A1A9  
(Sheet 3 of 6)

FP-107/(FP-108 Blank)



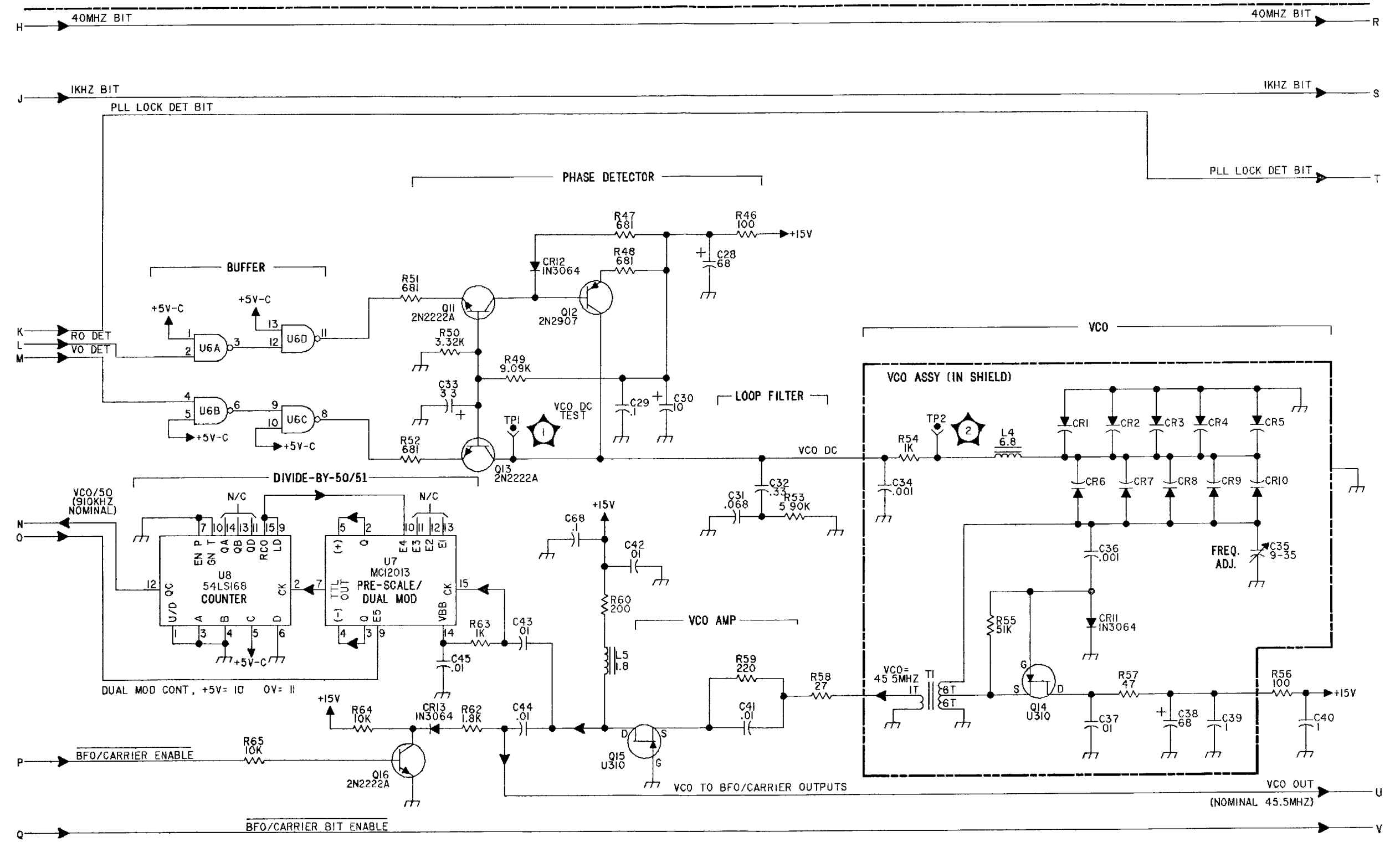

FO-10. REF/BFO PWB ASSY, A1A9  
(Sheet 4 of 6)

FP-109/(FP-110 Blank)



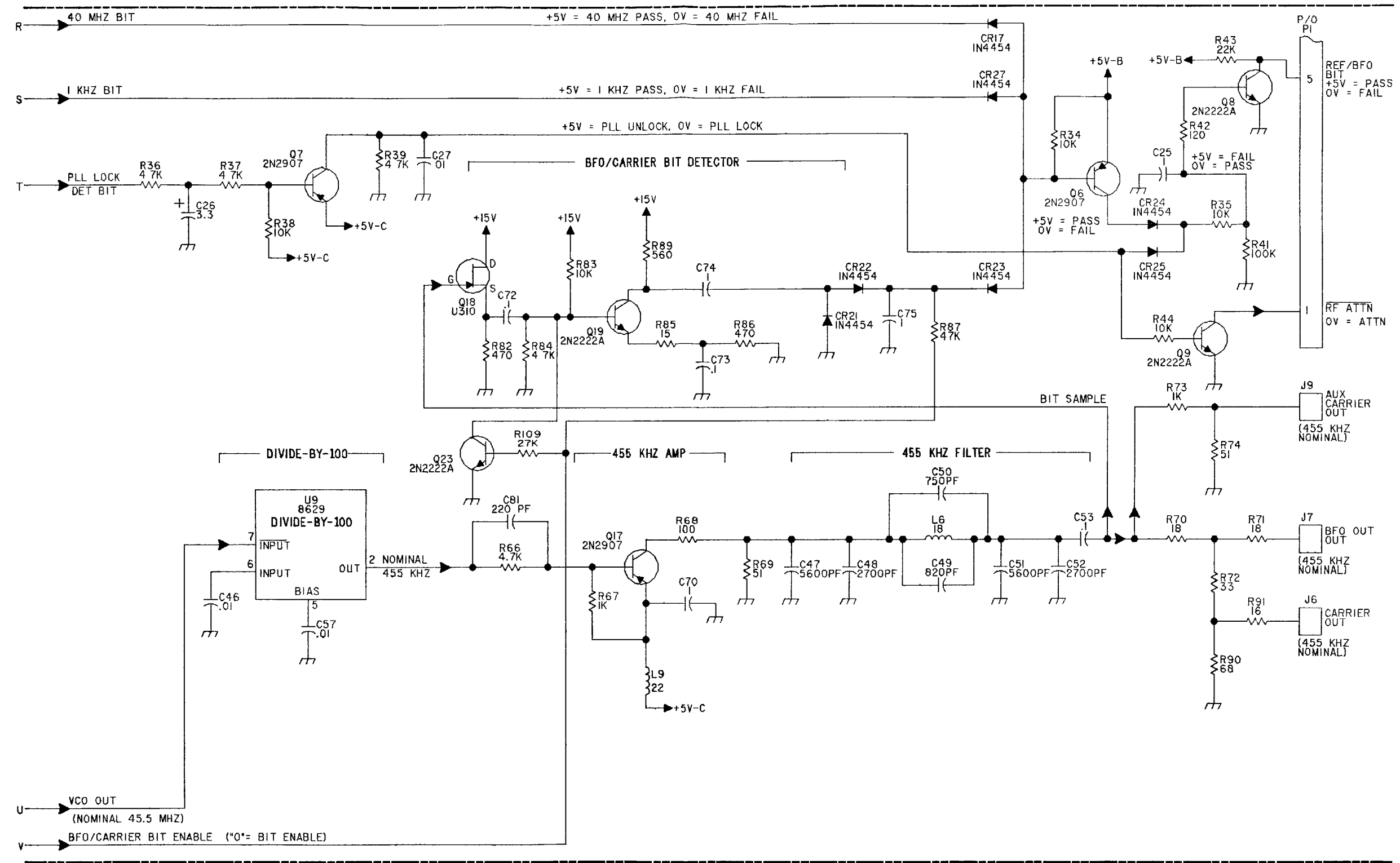

FO-10. REF/BFO PWB ASSY, A1A9  
(Sheet 5 of 6)



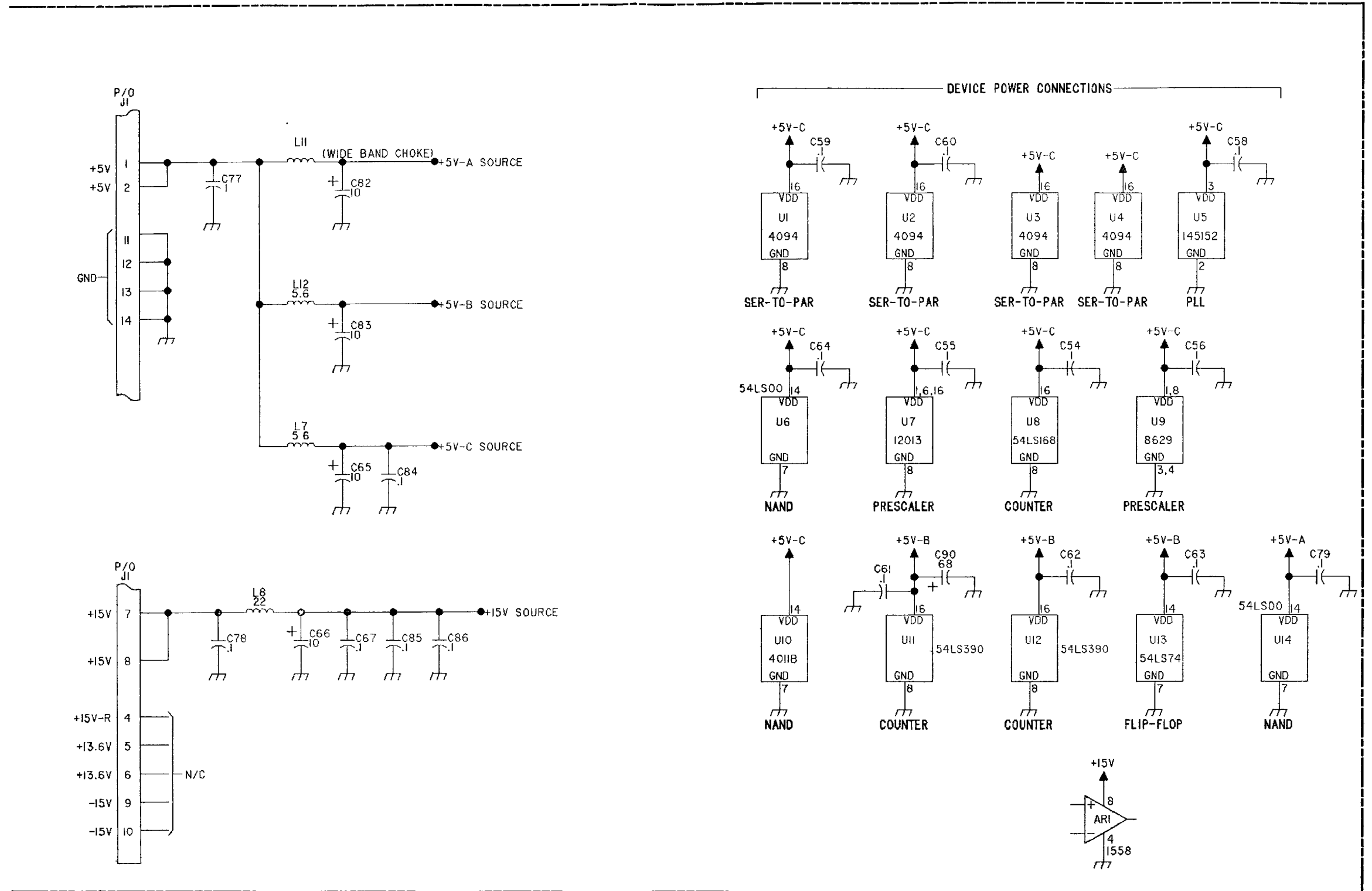





NOTE: UNLESS OTHERWISE SPECIFIED

1. PARTIAL REFERENCE DESIGNATIONS ARE SHOWN FOR DETAIL PARTS. PREFIX THESE WITH UNIT NO. AND/OR ASSEMBLY DESIGNATIONS SHOWN ON DRAWING TO OBTAIN COMPLETE DESIGNATIONS.
2. ALL RESISTOR VALUES ARE IN OHMS, 1/4W, ±5%
3. ALL CAPACITOR VALUES ARE IN MICROFARADS (UF)
4. ALL INDUCTANCE VALUES ARE IN MICROHENRIES (UH).
5. VENDOR PART NO. CALLOUTS ARE FOR REFERENCE ONLY. COMPONENTS ARE SUPPLIED PER PART NO. IN PARTS LIST
6. DC RESISTANCES OF INDUCTIVE ELEMENTS (CHOKES, COILS, MOTOR WINDINGS, ETC.) ARE LESS THAN 1 OHM.
7. PANEL DECALS ARE INDICATED BY BOLD TYPE IN A BOLD BOX, E.G. **ON/OFF**
8. ALL RELAYS ARE SHOWN IN THE DE-ENERGIZED STATE.

HIGHEST REFERENCE DESIGNATION	
REFERENCE DESIGNATIONS NOT USED	

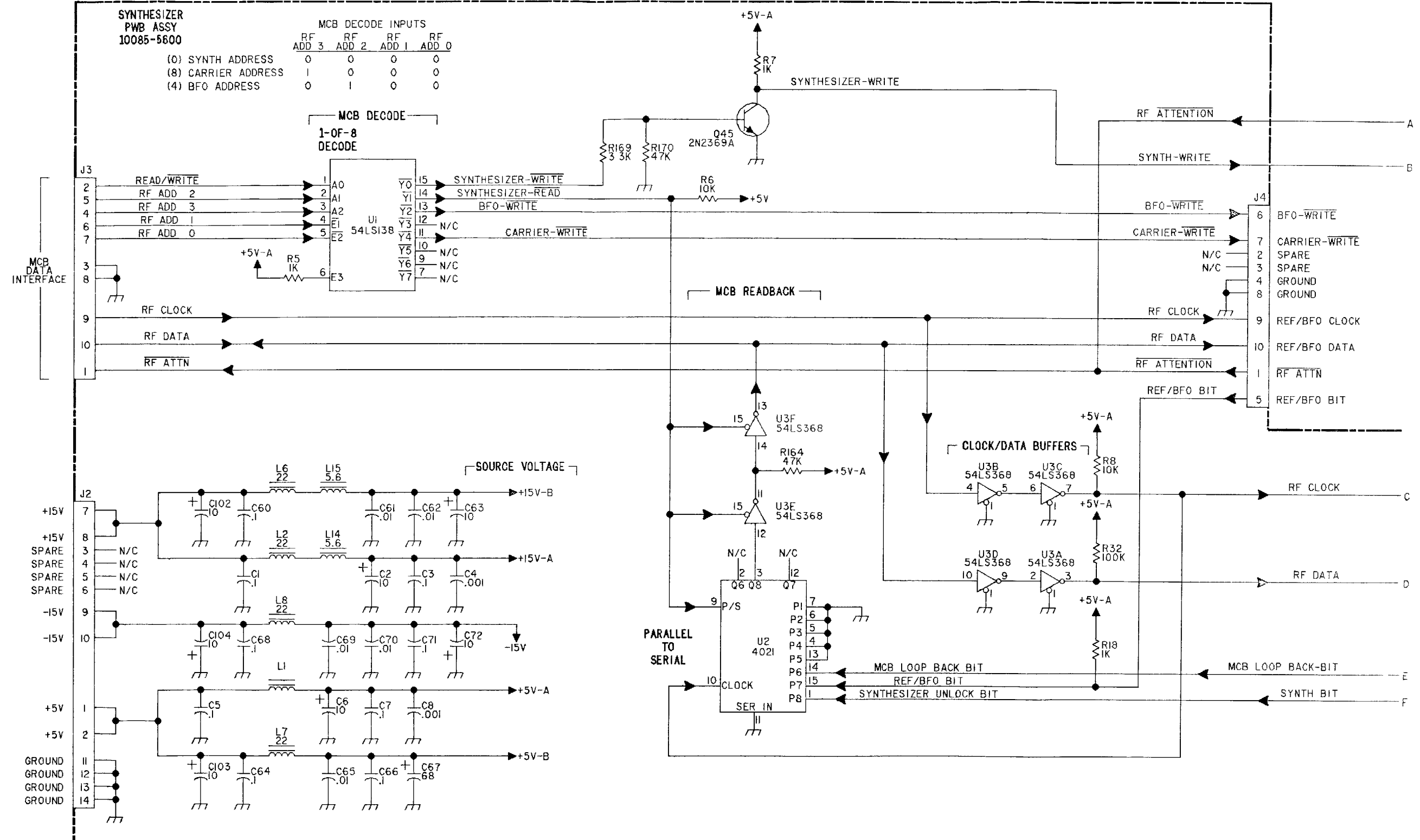
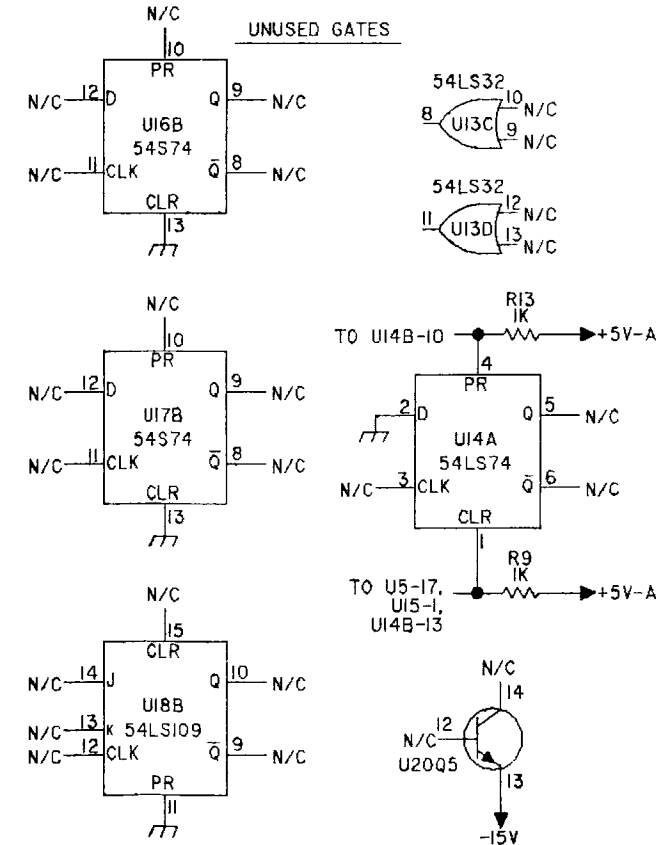

FO-11. SYNTHESIZER PWB ASSY, A1A10 (Sheet 1 of 7)



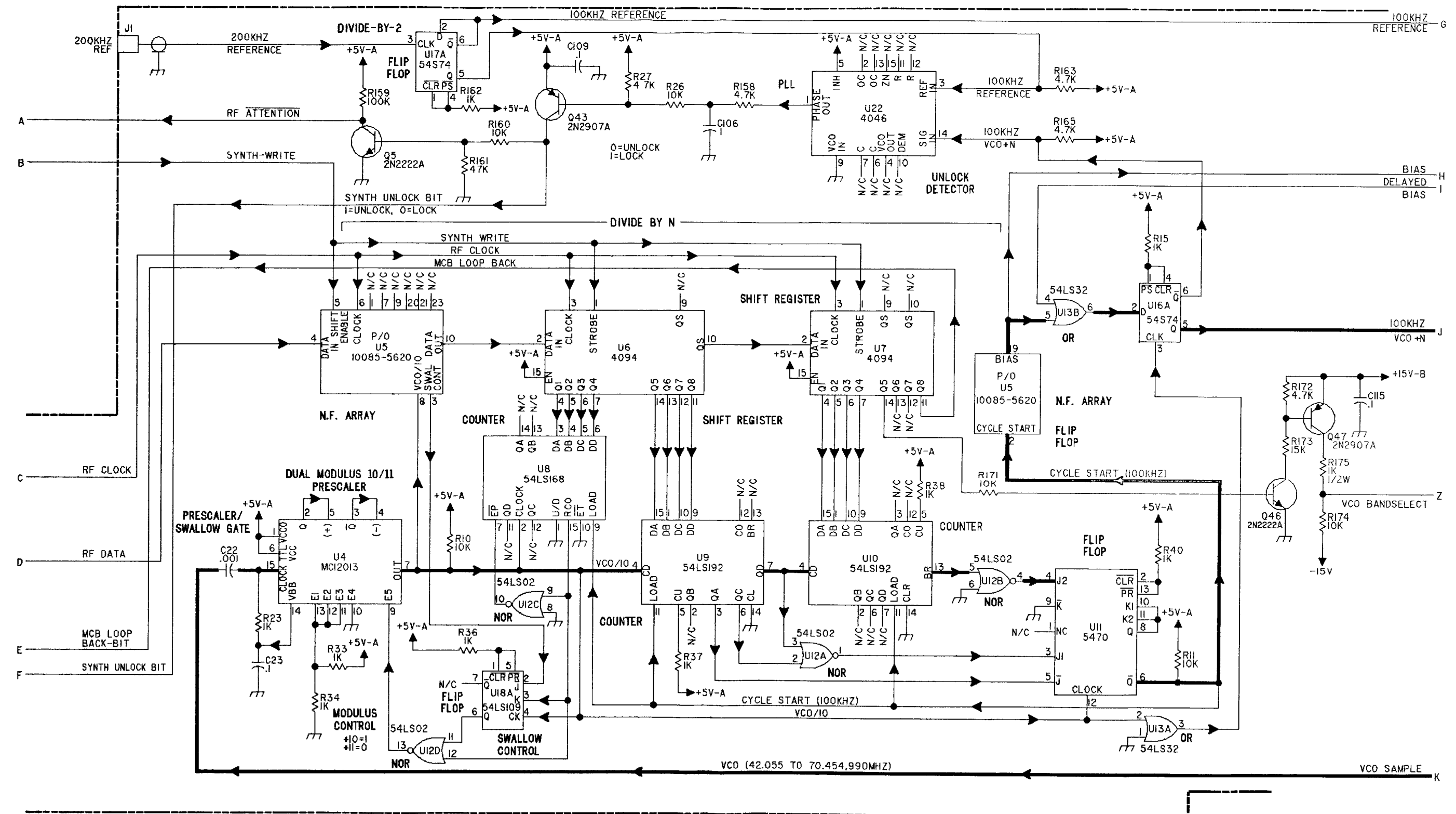

FO-11. SYNTHESIZER PWB ASSY, A1A10  
(Sheet 2 of 7)

FP-117/(FP-118 Blank)



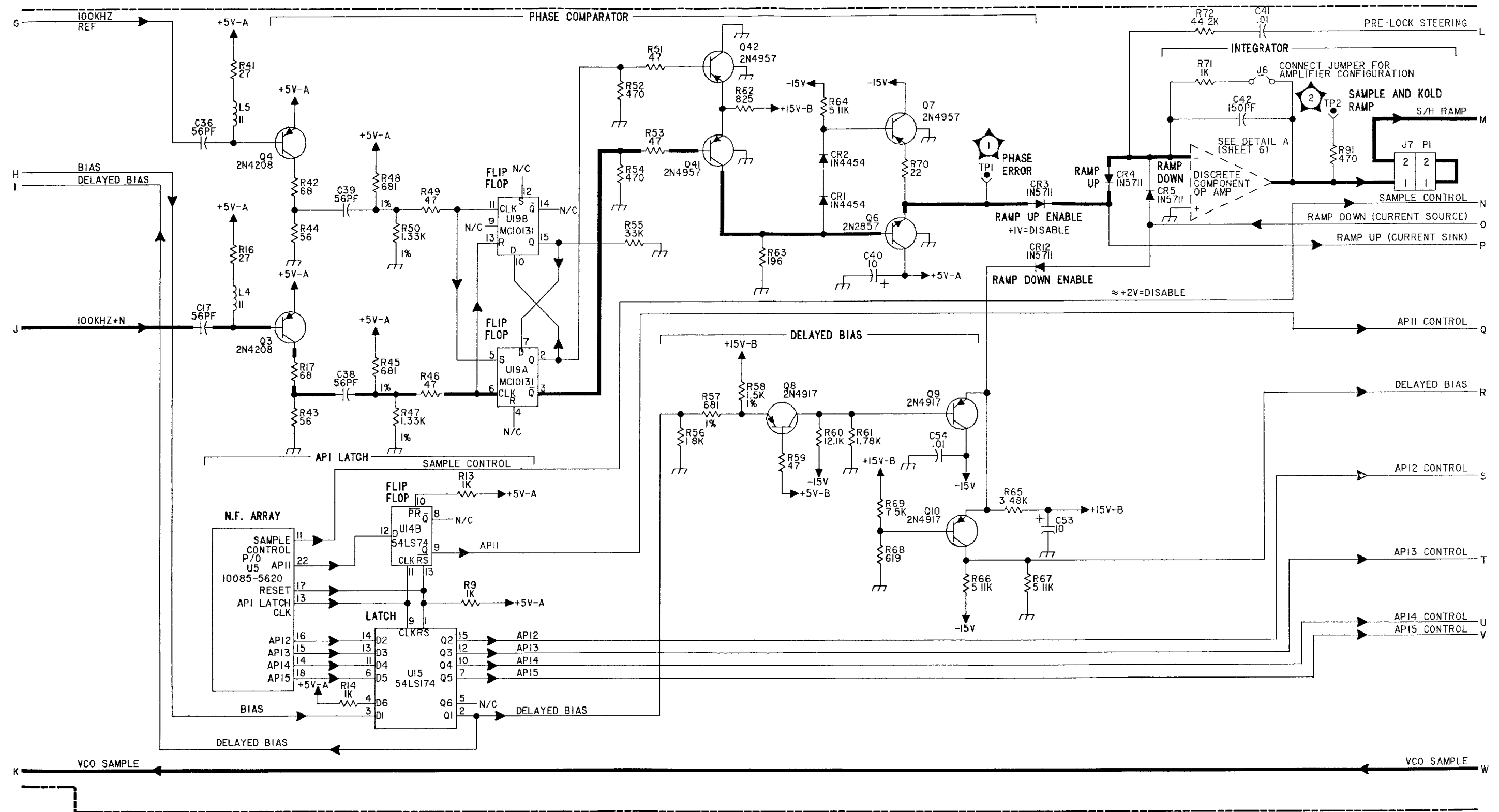



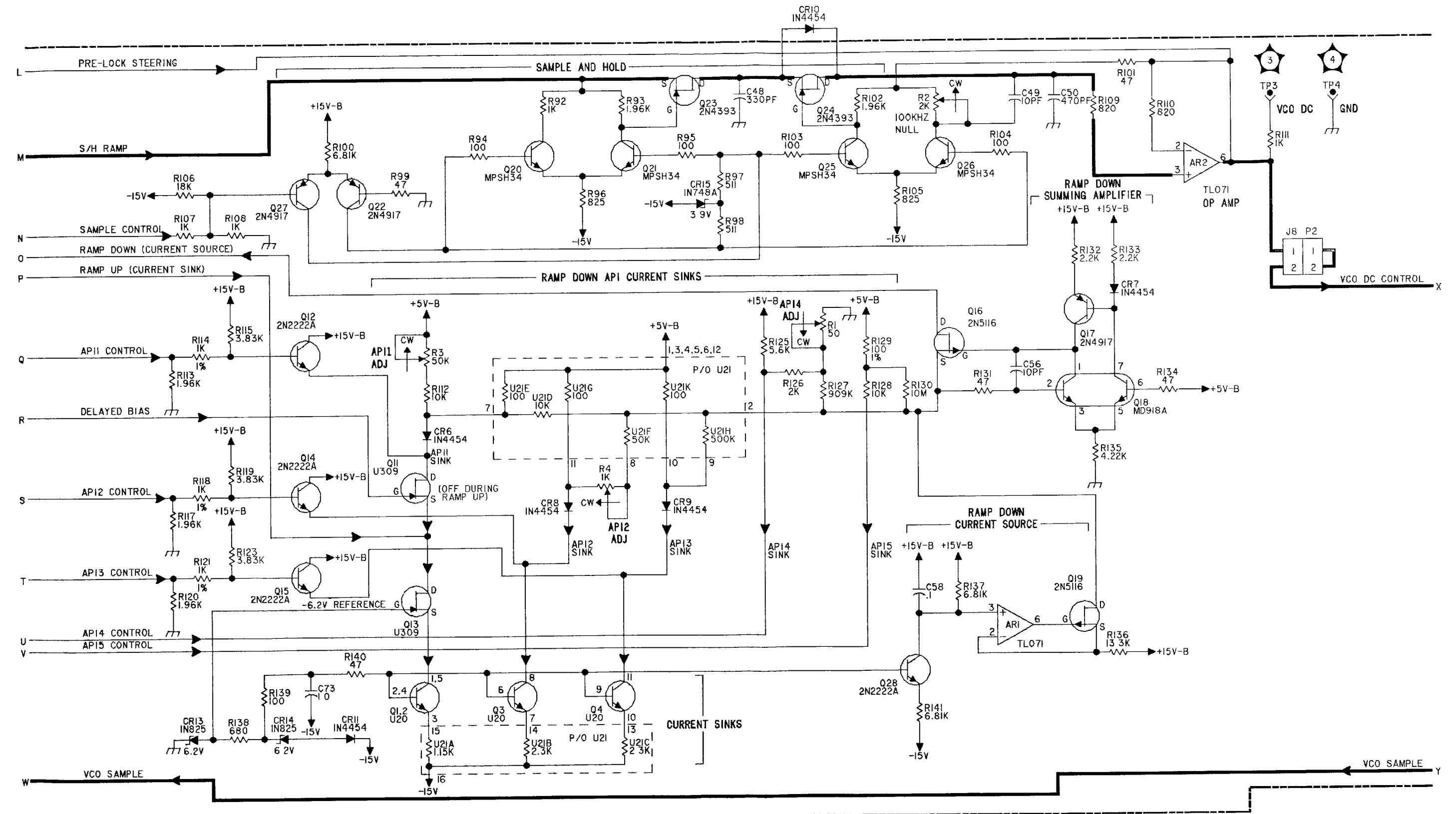

FO-11. SYNTHESIZER PWB ASSY, A1A10  
(Sheet 4 of 7)





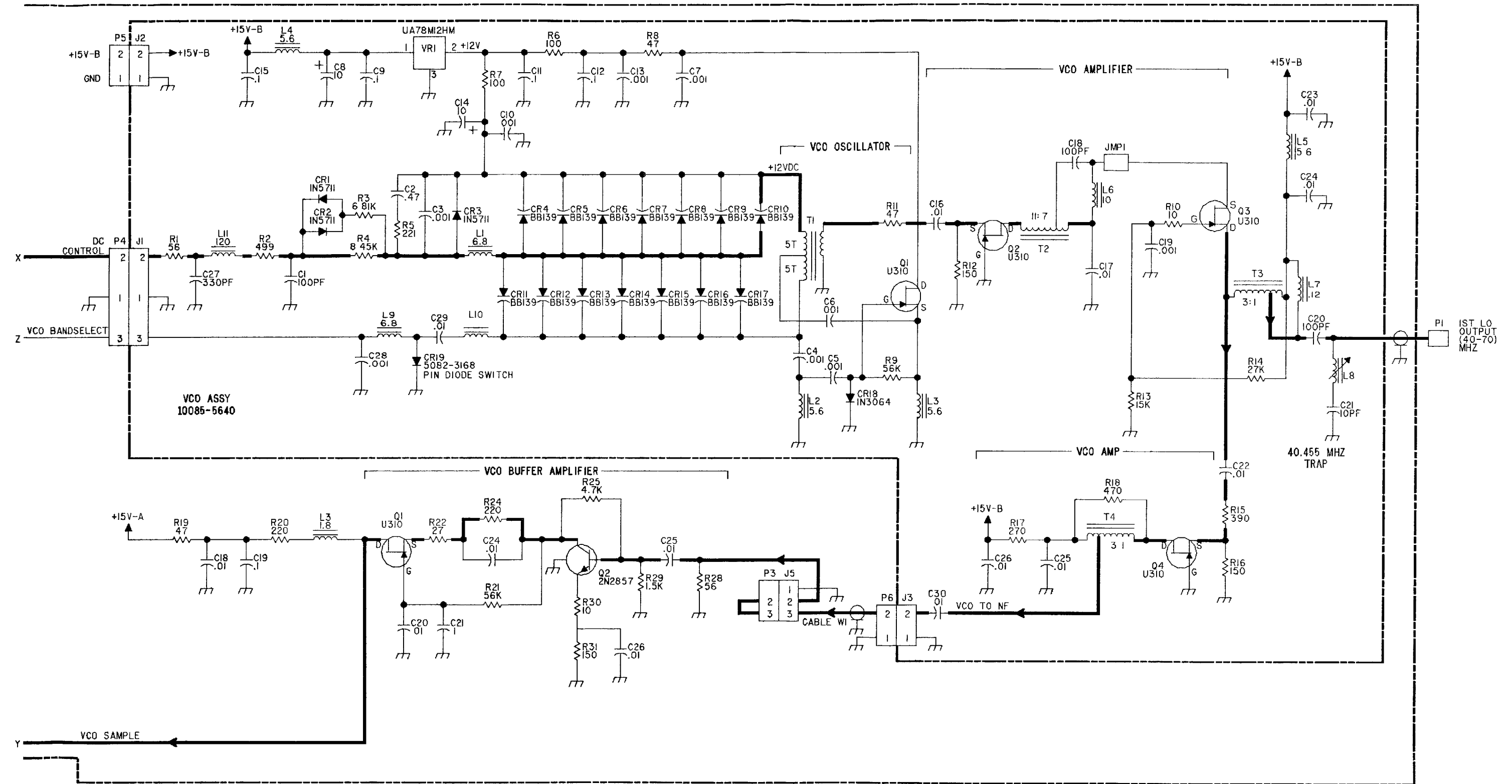

FO-11. SYNTHESIZER PWB ASSY, A1A10  
(Sheet 5 of 7)



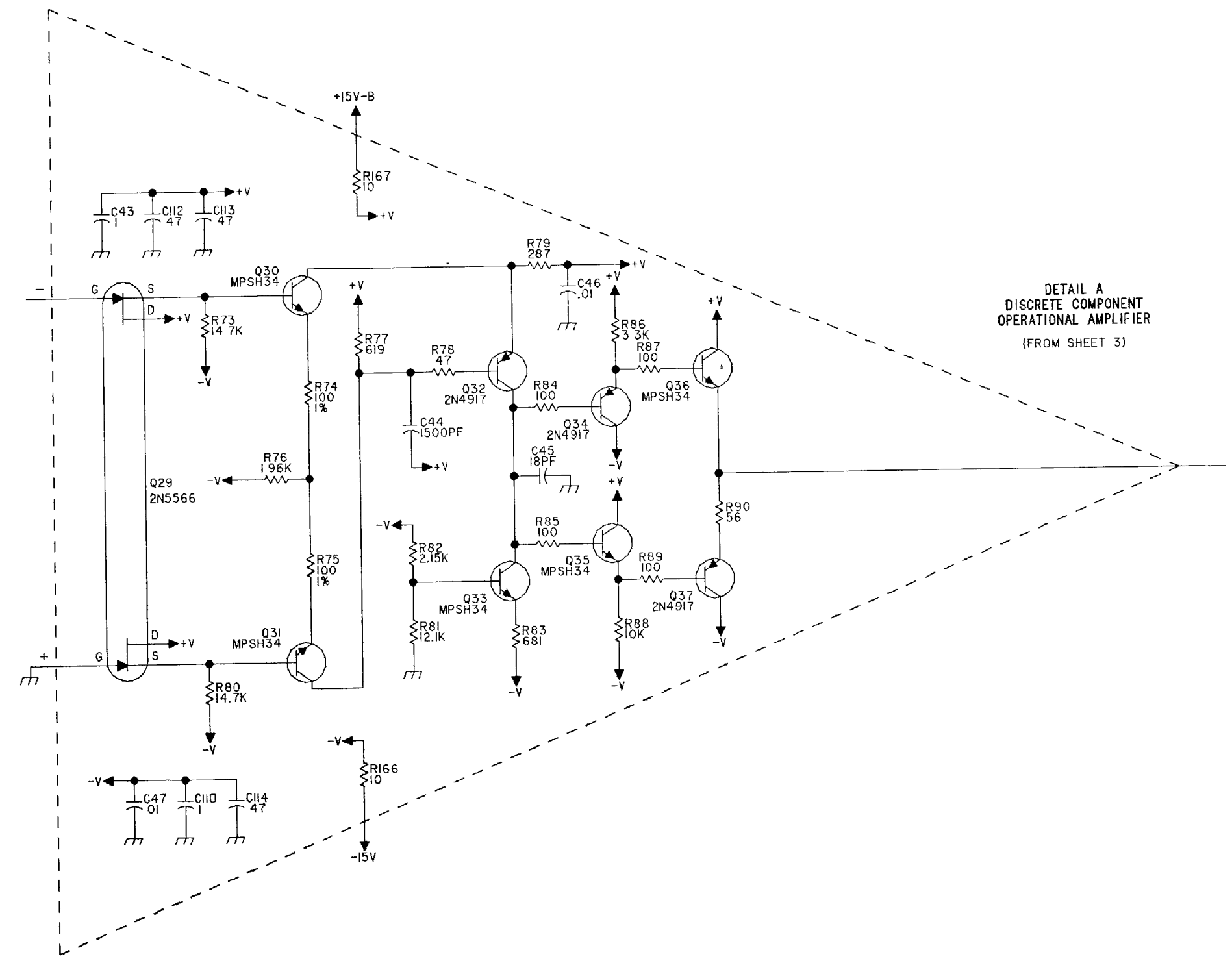
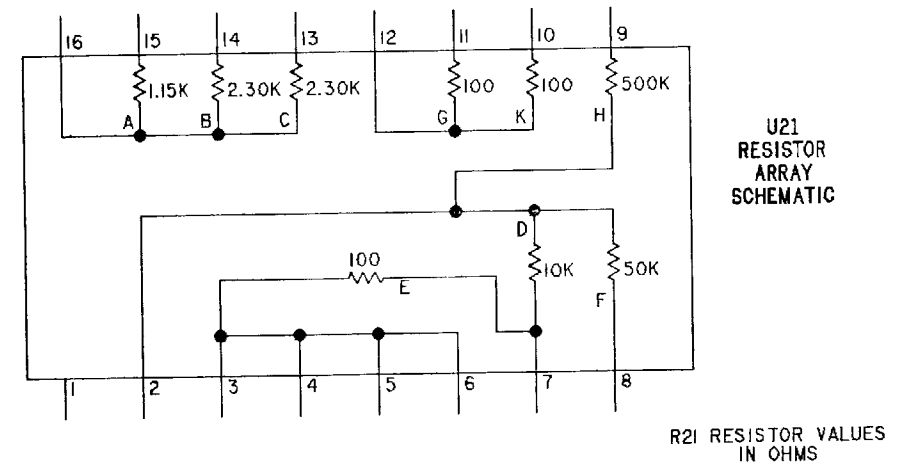



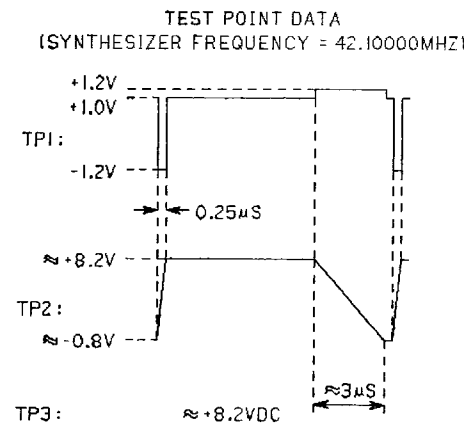
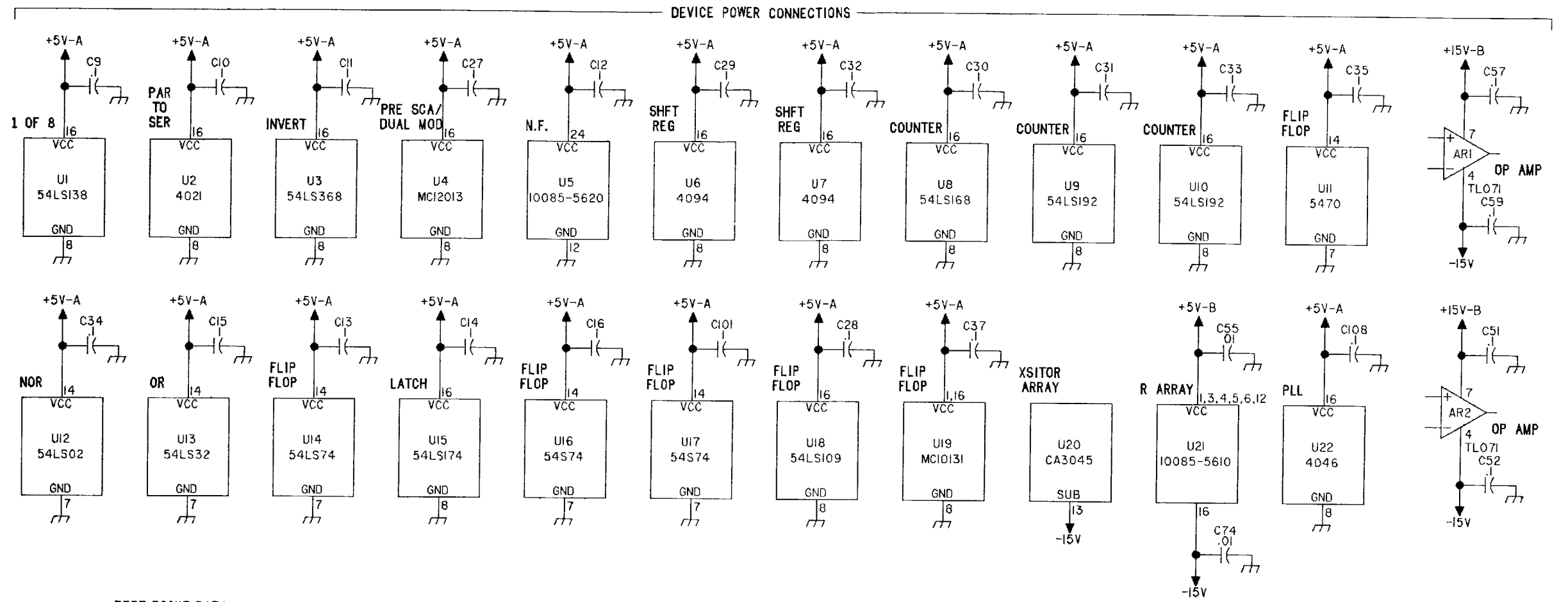



NOTE: UNLESS OTHERWISE SPECIFIED:

1. PARTIAL REFERENCE DESIGNATIONS ARE SHOWN FOR DETAIL PARTS. PREFIX THESE WITH UNIT NO. AND/OR ASSEMBLY DESIGNATIONS SHOWN ON DRAWING TO OBTAIN COMPLETE DESIGNATIONS.
2. ALL RESISTOR VALUES ARE IN OHMS, 1/4W, ±5%.
3. ALL CAPACITOR VALUES ARE IN MICROFARADS (UF)
4. ALL INDUCTANCE VALUES ARE IN MILLIHENRIES (MH)
5. VENDOR PART NO. CALLOUTS ARE FOR REFERENCE ONLY. COMPONENTS ARE SUPPLIED PER PART NO IN PARTS LIST.
6. DC RESISTANCES OF INDUCTIVE ELEMENTS (CHOKES, COILS, MOTOR WINDINGS, ETC.) ARE LESS THAN 1 OHM.
7. PANEL DECALS ARE INDICATED BY BOLD TYPE IN A BOLD BOX, E.G., **ON/OFF**.
8. ALL RELAYS ARE SHOWN IN THE DE-ENERGIZED STATE.

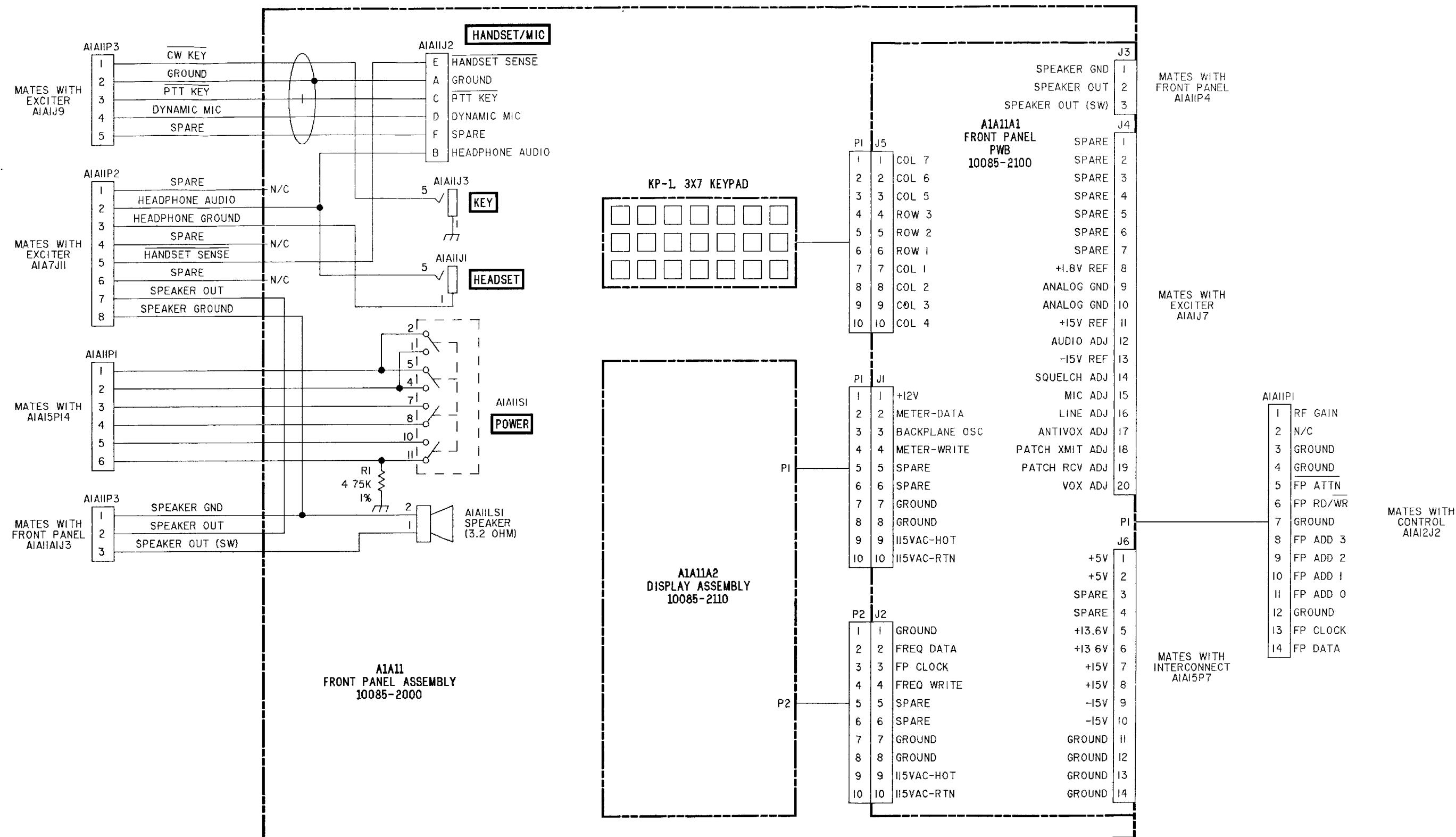

FO-12. FRONT PANEL ASSY, A1A11  
FP-129/(FP-130 Blank)





NOTE: UNLESS OTHERWISE SPECIFIED

1. PARTIAL REFERENCE DESIGNATIONS ARE SHOWN FOR DETAIL PARTS. PREFIX THESE WITH UNIT NO. AND/OR ASSEMBLY DESIGNATIONS SHOWN ON DRAWING TO OBTAIN COMPLETE DESIGNATIONS.
2. ALL RESISTOR VALUES ARE IN OHMS, 1/4W, ±5%.
3. ALL CAPACITOR VALUES ARE IN MICROFARADS (µF).
4. ALL INDUCTANCE VALUES ARE IN MICROHENRIES (µH).
5. VENDOR PART NO. CALLOUTS ARE FOR REFERENCE ONLY COMPONENTS ARE SUPPLIED PER PART NO. IN PARTS LIST
6. DC RESISTANCES OF INDUCTIVE ELEMENTS (CHOKES, COILS, MOTOR WINDINGS, ETC.,) ARE LESS THAN 1 OHM.
7. PANEL DECALS ARE INDICATED BY BOLD TYPE IN A BOLD BOX, E.G., **ON/OFF**.
8. ALL RELAYS ARE SHOWN IN THE DE-ENERGIZED STATE.
9. **4** SHOWS W/ CONNECTION AT PWB FOR PI.

HIGHEST REFERENCE DESIGNATION	
REFERENCE DESIGNATIONS NOT USED	

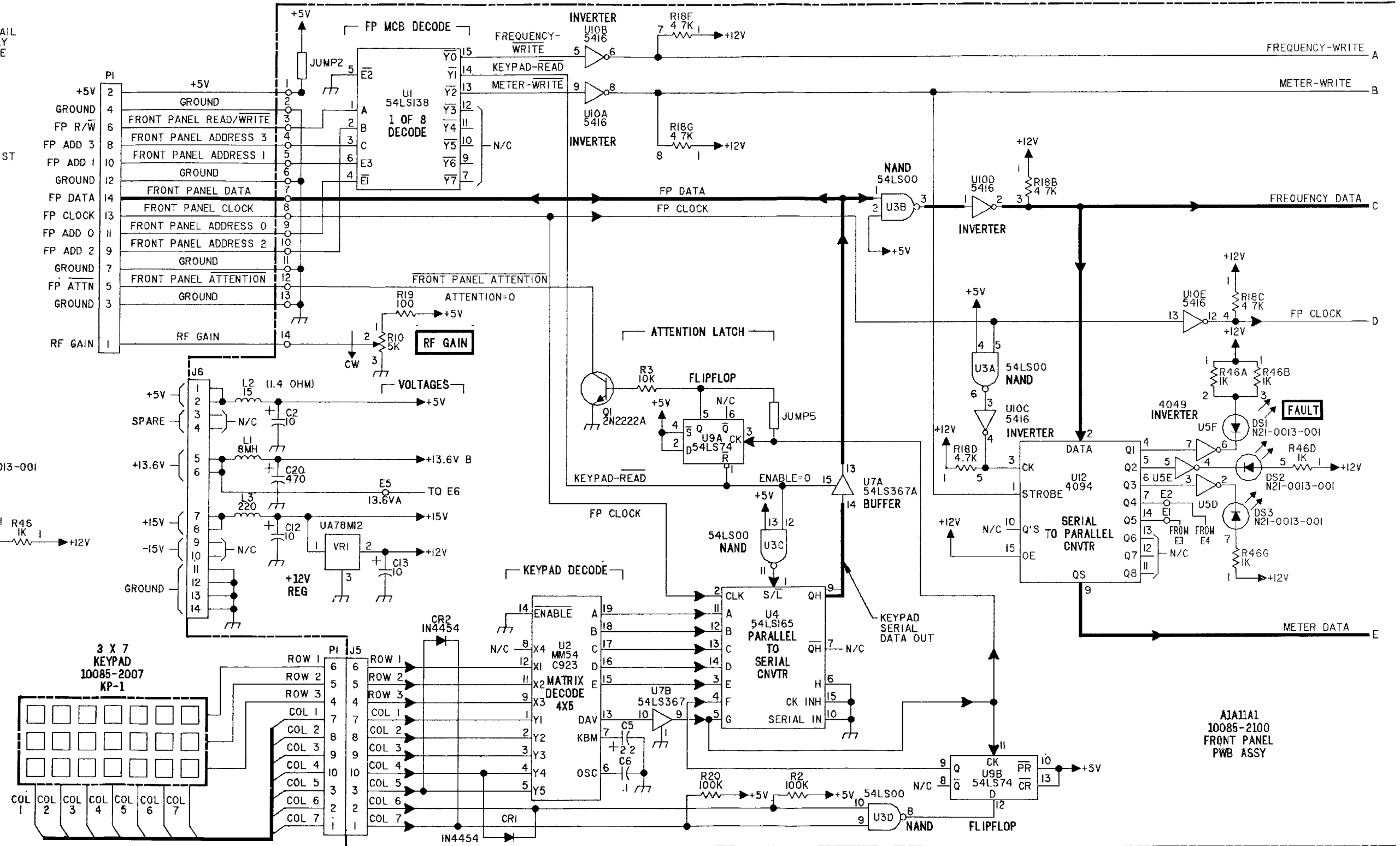
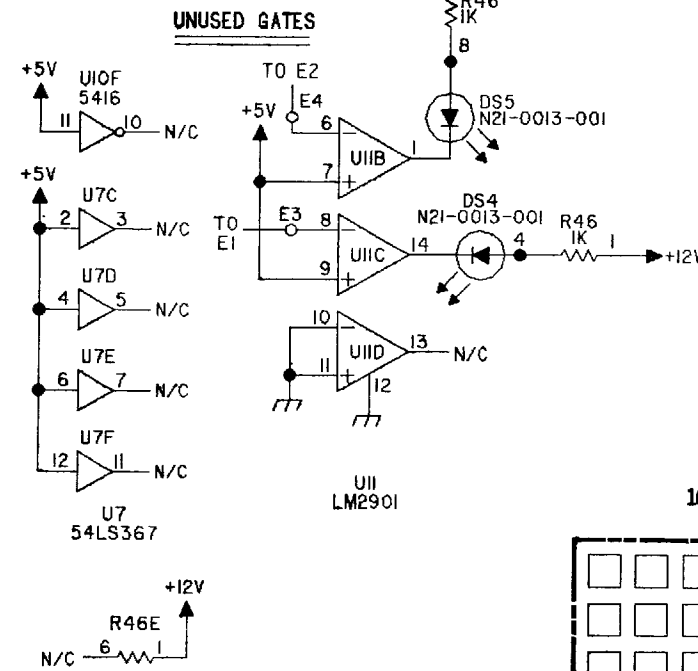

FO-13. FRONT PANEL PWB ASSY, A1A11A1 (Sheet 1 of 2)  
FP-131/(FP-132 Blank)



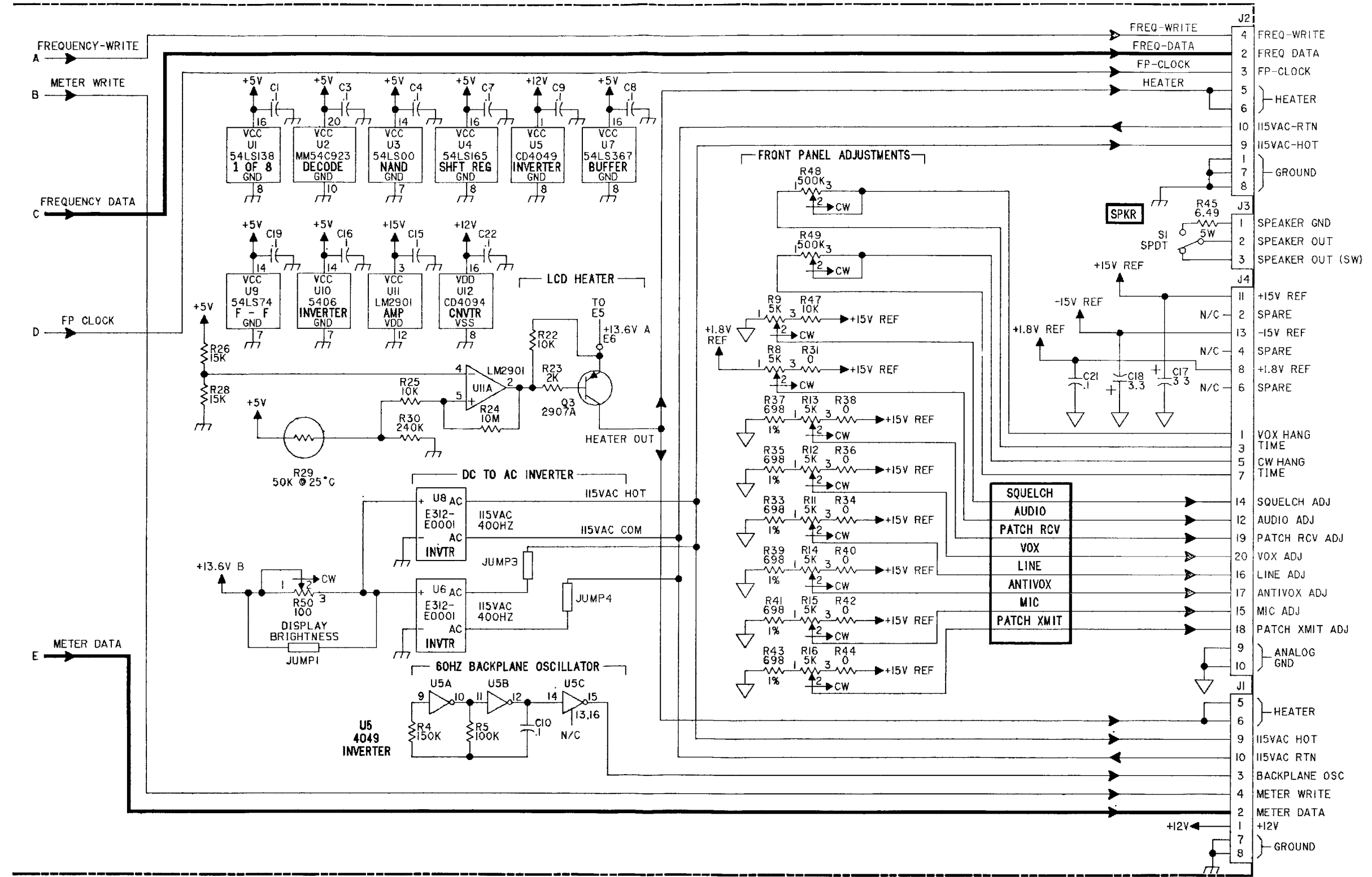

FO-13. FRONT PANEL PWB ASSY, A1A11A1 (Sheet 2 of 2)



NOTE: UNLESS OTHERWISE SPECIFIED:

1. PARTIAL REFERENCE DESIGNATIONS ARE SHOWN FOR DETAIL PARTS. PREFIX THESE WITH UNIT NO. AND/OR ASSEMBLY DESIGNATIONS SHOWN ON DRAWING TO OBTAIN COMPLETE DESIGNATIONS.
2. ALL RESISTOR VALUES ARE IN OHMS, 1/4W, ±5%
3. ALL CAPACITOR VALUES ARE IN MICROFARADS (UF).
4. ALL INDUCTANCE VALUES ARE IN MILLIHENRIES (MH).
5. VENDOR PART NO. CALLOUTS ARE FOR REFERENCE ONLY. COMPONENTS ARE SUPPLIED PER PART NO. IN PARTS LIST.
6. DC RESISTANCES OF INDUCTIVE ELEMENTS (CHOKES, COILS, MOTOR WINDINGS, ETC.) ARE LESS THAN 1 OHM.
7. PANEL DECALS ARE INDICATED BY BOLD TYPE IN A BOLD BOX, E.G., **ON/OFF**.
8. ALL RELAYS ARE SHOWN IN THE DE-ENERGIZED STATE.

HIGHEST REFERENCE DESIGNATION			
REFERENCE DESIGNATIONS NOT USED			

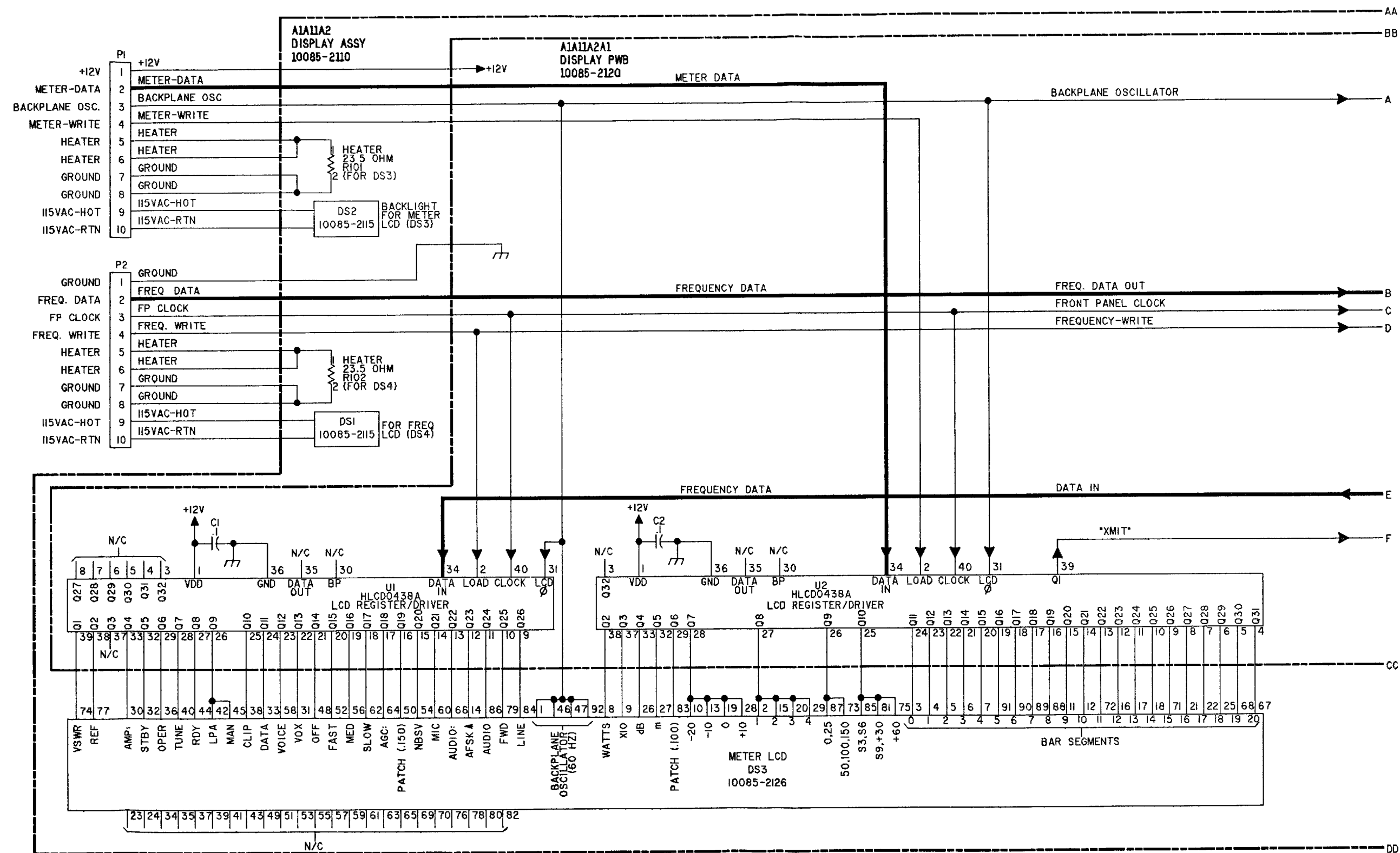

FO-14. DISPLAY ASSY, A1A11A2  
(Sheet 1 of 3)



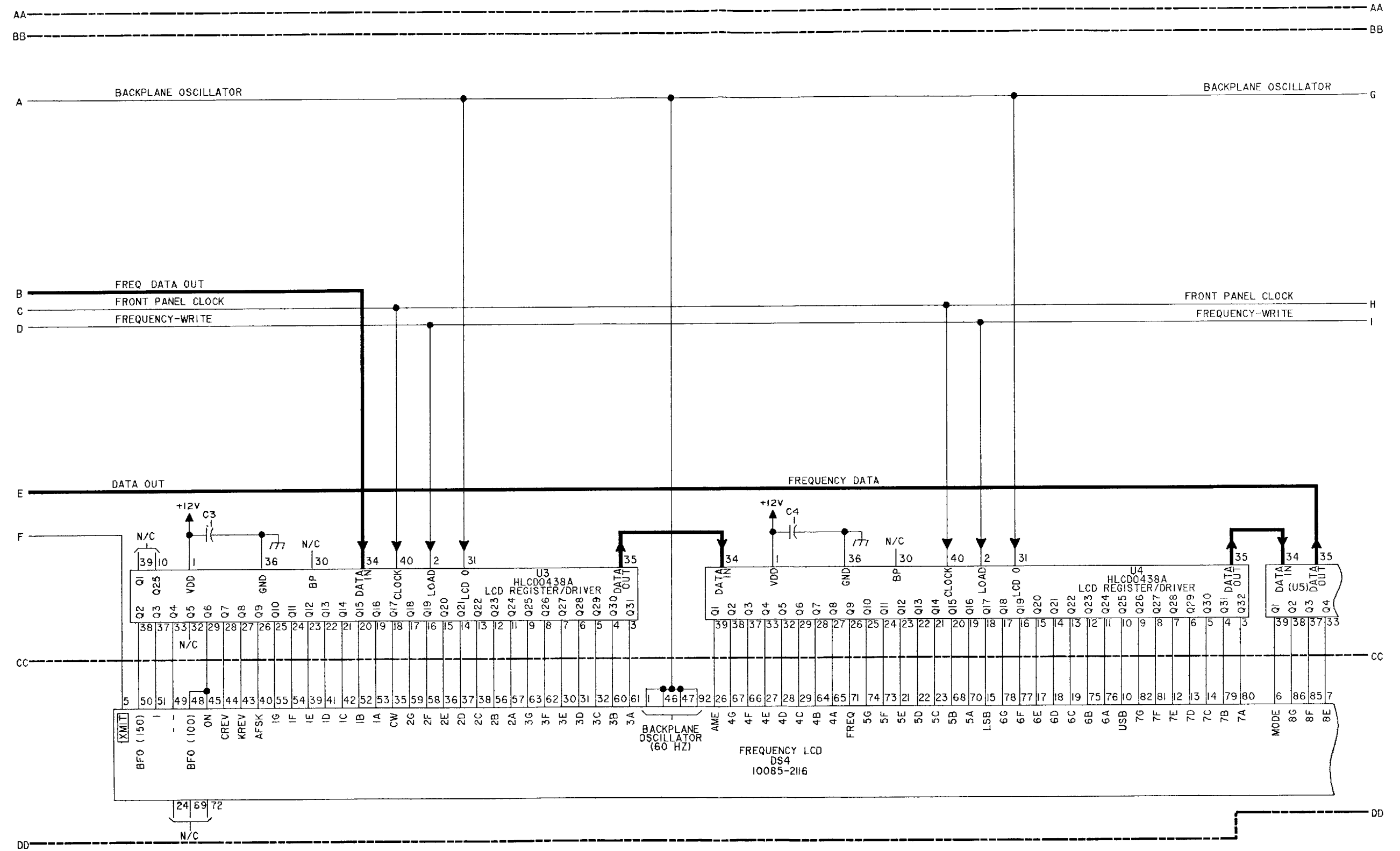

FO-14. DISPLAY ASSY, A1A11A2  
(Sheet 2 of 3)





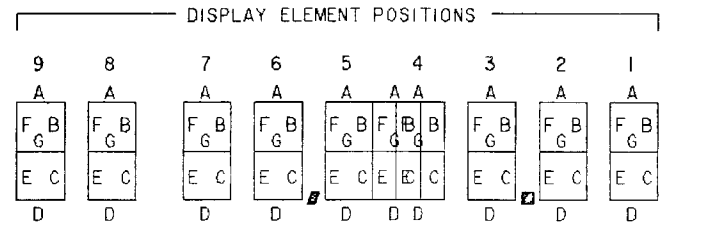
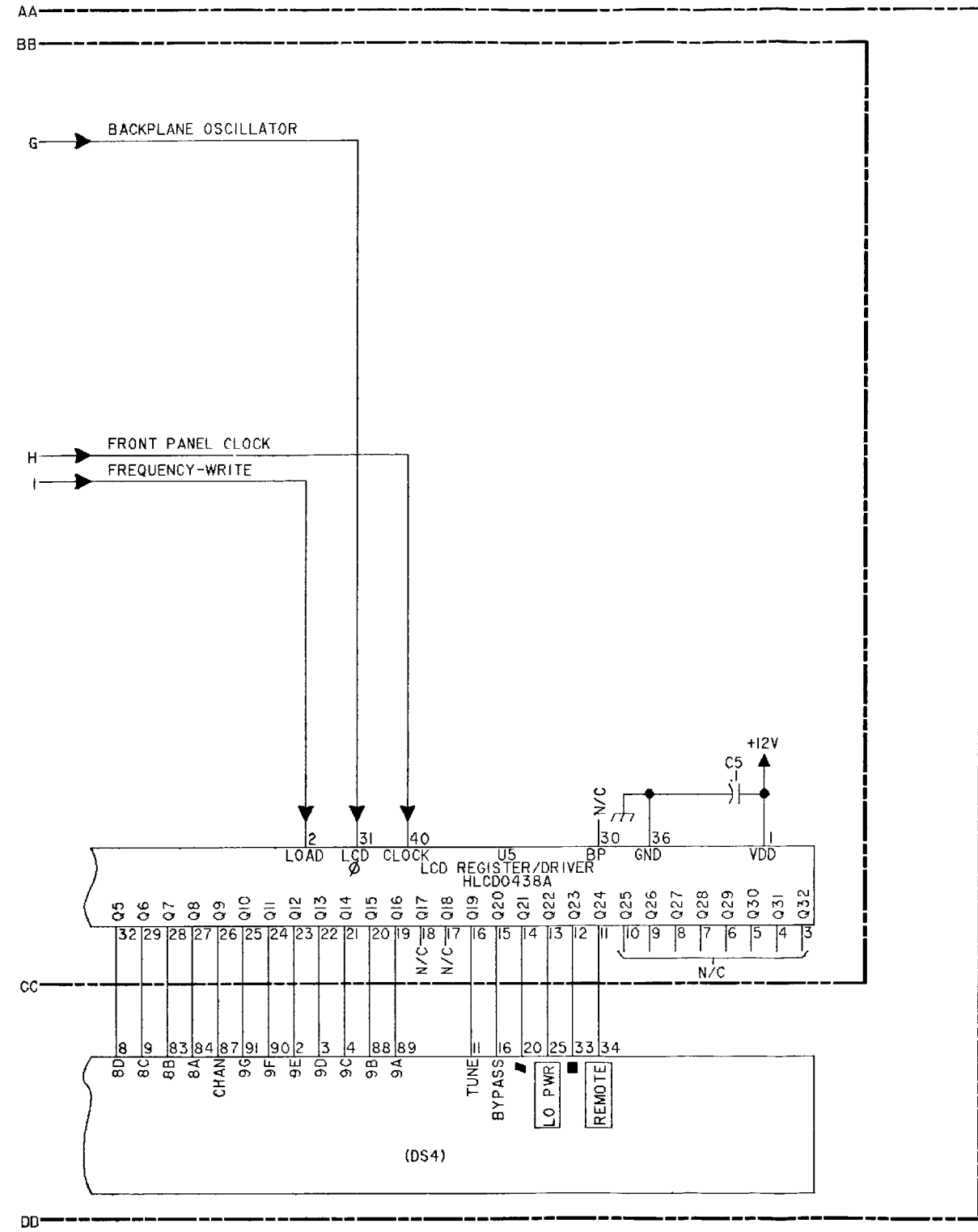



NOTE: UNLESS OTHERWISE SPECIFIED:

1. PARTIAL REFERENCE DESIGNATIONS ARE SHOWN FOR DETAIL PARTS. PREFIX THESE WITH UNIT NO. AND/OR ASSEMBLY DESIGNATIONS SHOWN ON DRAWING TO OBTAIN COMPLETE DESIGNATIONS.
2. ALL RESISTOR VALUES ARE IN OHMS, 1/4W, ±5%.
3. ALL CAPACITOR VALUES ARE IN MICROFARADS (UF).
4. ALL INDUCTANCE VALUES ARE IN MICROHENRIES (UH).
5. VENDOR PART NO. CALLOUTS ARE FOR REFERENCE ONLY. COMPONENTS ARE SUPPLIED PER PART NO. IN PARTS LIST.
6. DC RESISTANCES OF INDUCTIVE ELEMENTS (CHOKES, COILS, MOTOR WINDINGS, ETC.) ARE LESS THAN 1 OHM.
7. PANEL DECALS ARE INDICATED BY BOLD TYPE IN A BOLD BOX, E.G., **ON/OFF**.
8. ALL RELAYS ARE SHOWN IN THE DE-ENERGIZED STATE.

HIGHEST REFERENCE DESIGNATION						
BT1	C60	CR5	J6	L4		
R73	SI	TPI	U42	VR4	Y1	
REFERENCE DESIGNATIONS NOT USED						

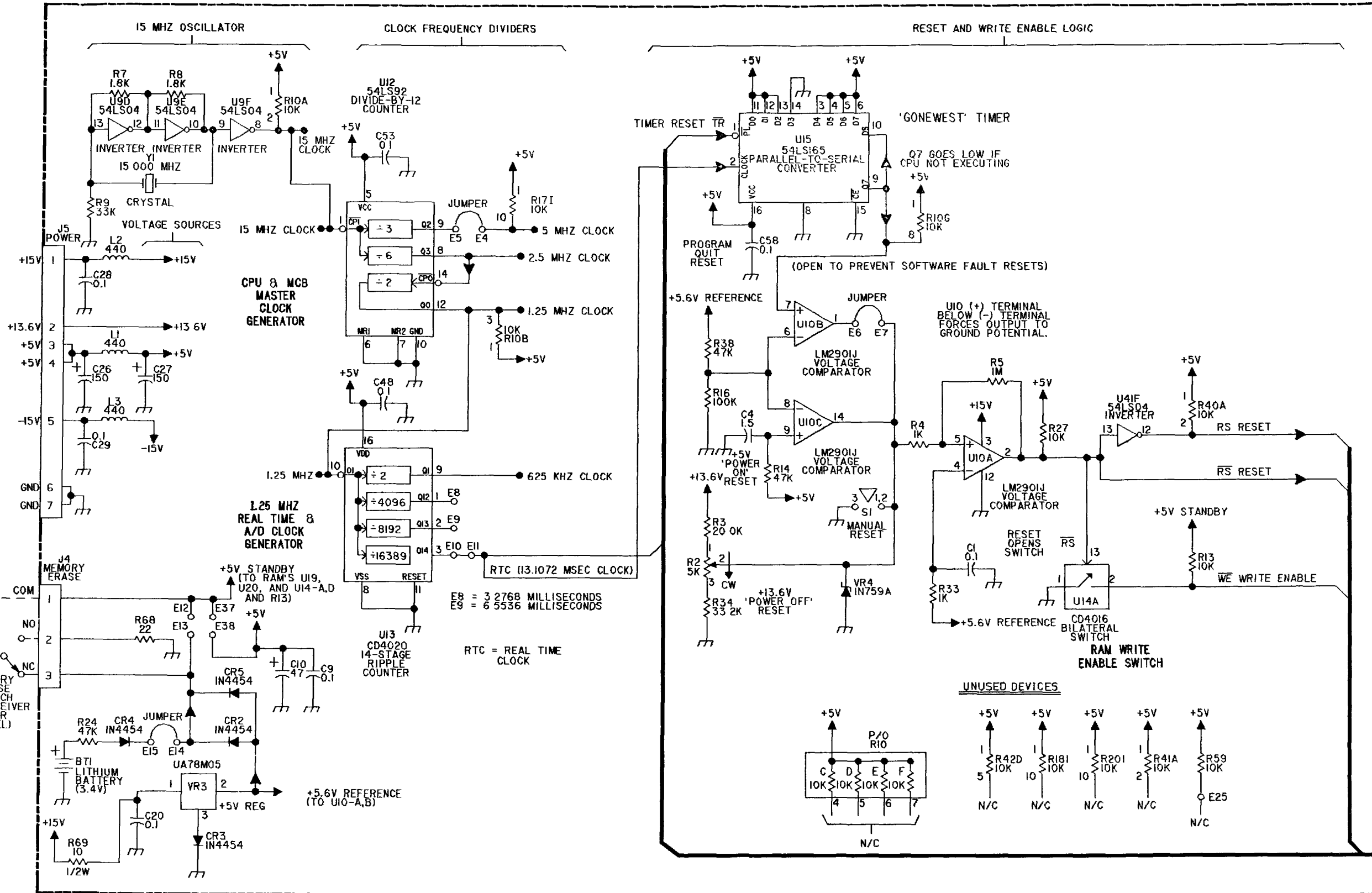
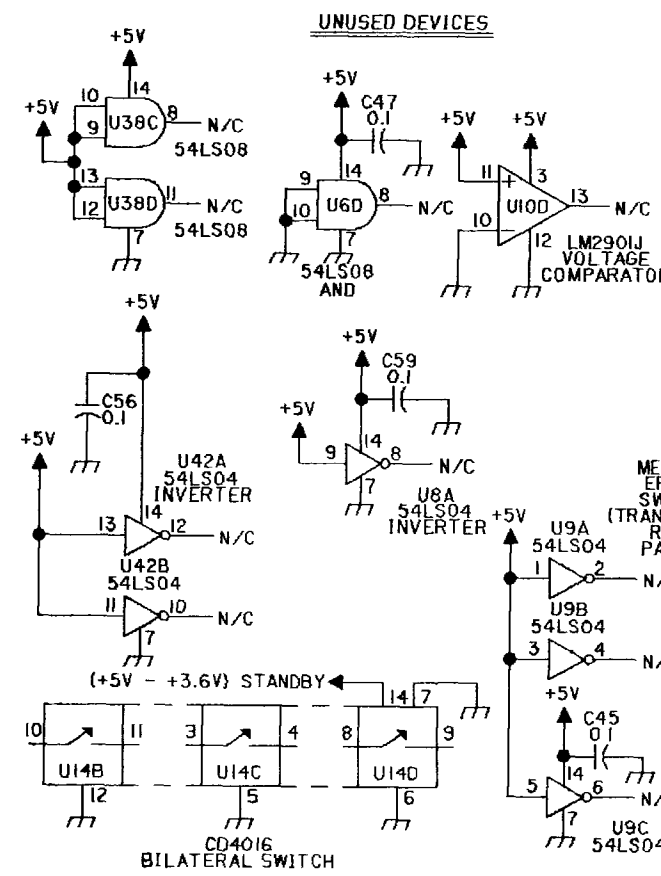

FO-15. TRANSCIVER CONTROL PWB ASSY, A1A12 (Sheet 1 of 9)



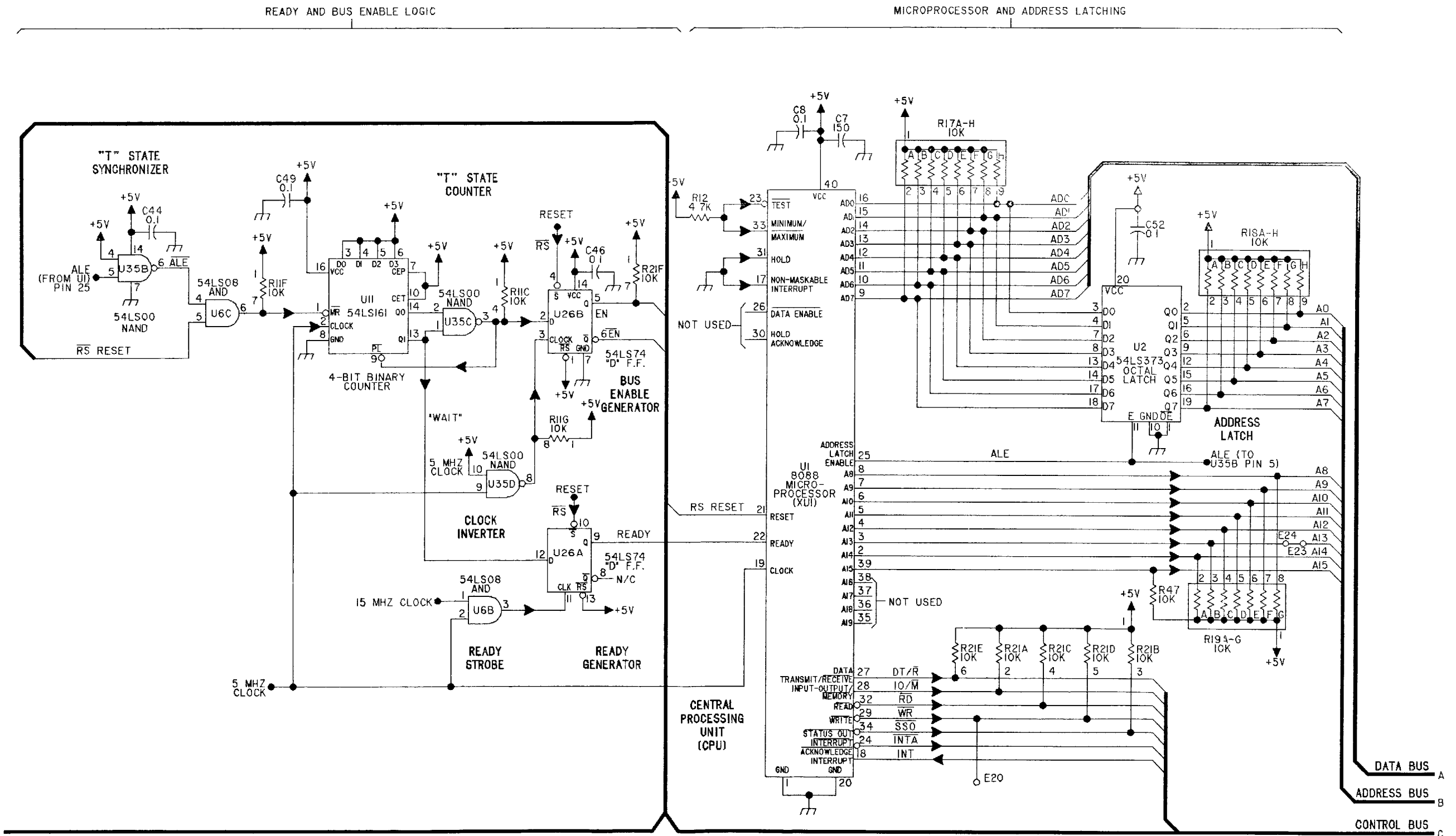

FO-15. TRANSCEIVER CONTROL PWB ASSY, A1A12 (Sheet 2 of 9)



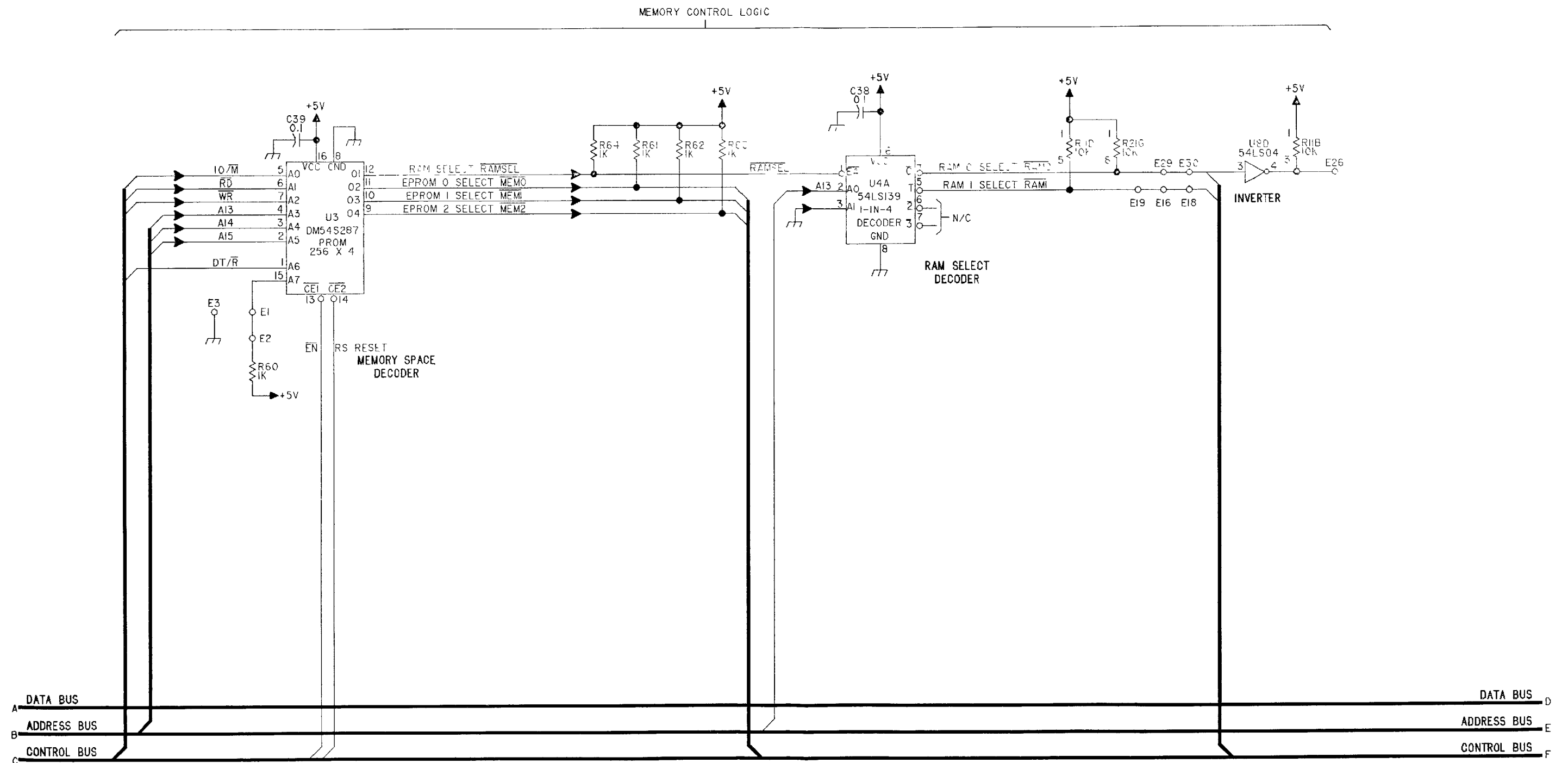

FO-15. TRANSCEIVER CONTROL PWB ASSY, A1A12 (Sheet 3 of 9)





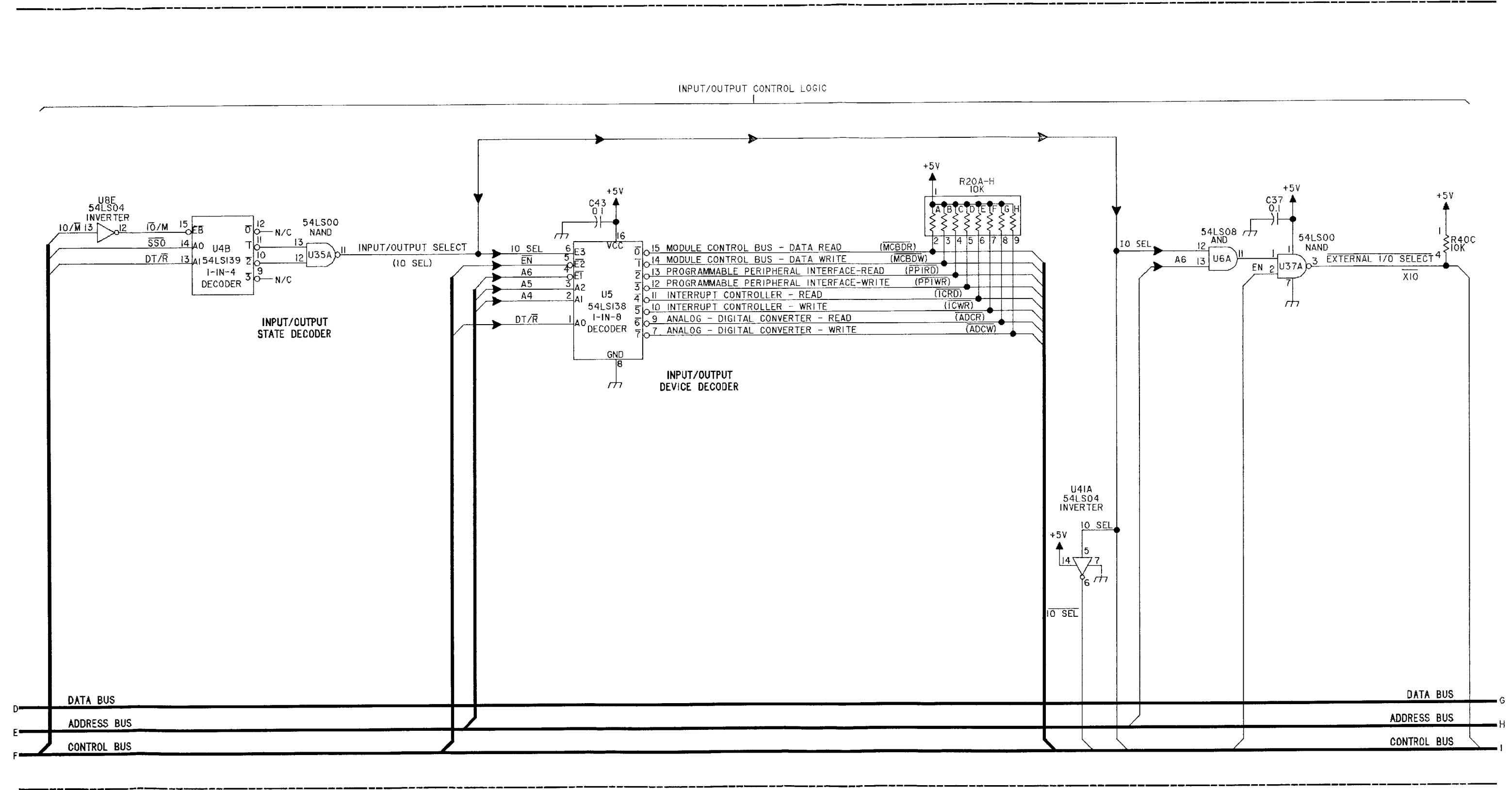

FO-15. TRANSCEIVER CONTROL PWB ASSY, A1A12 (Sheet 4 of 9)



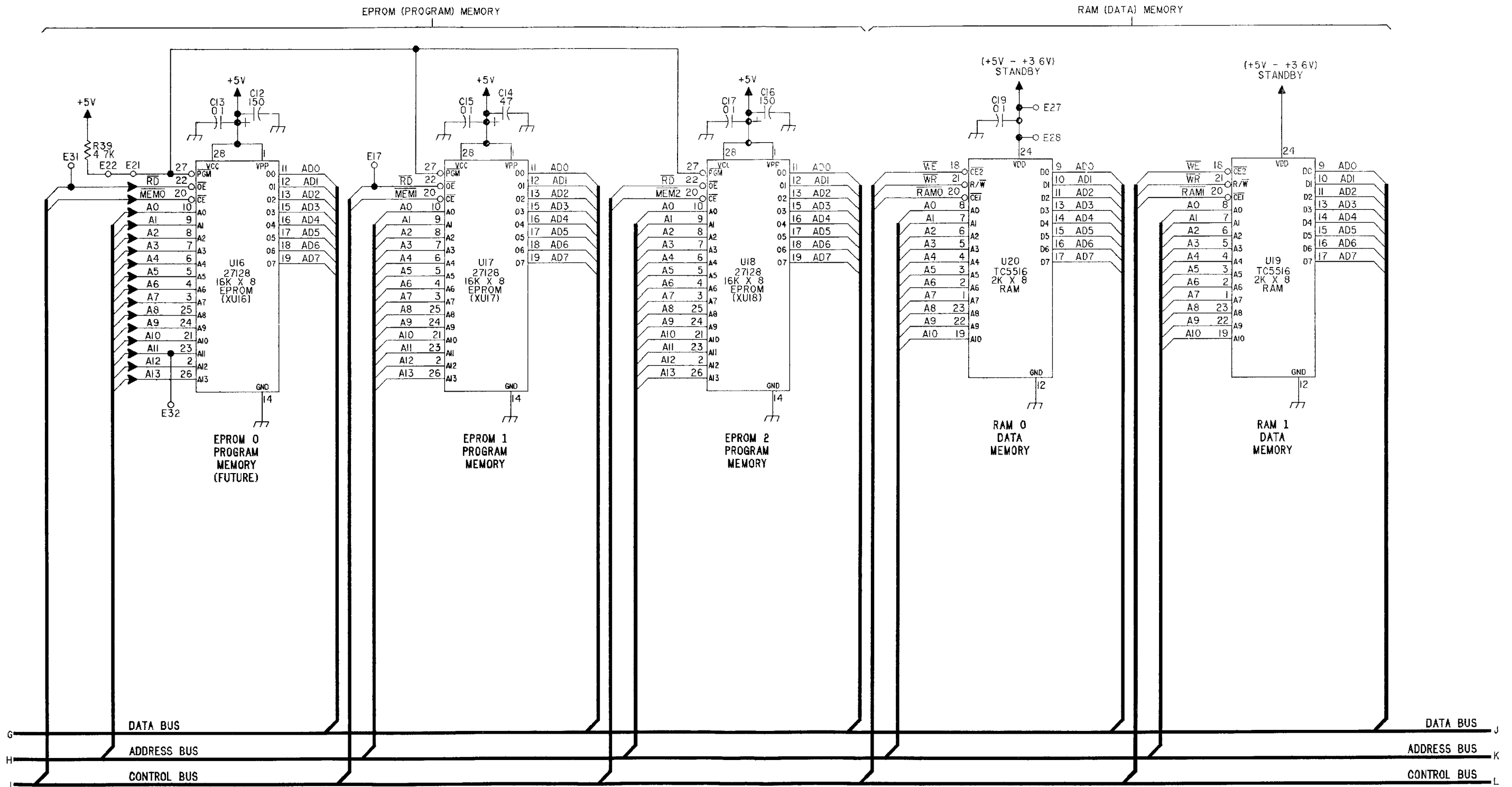



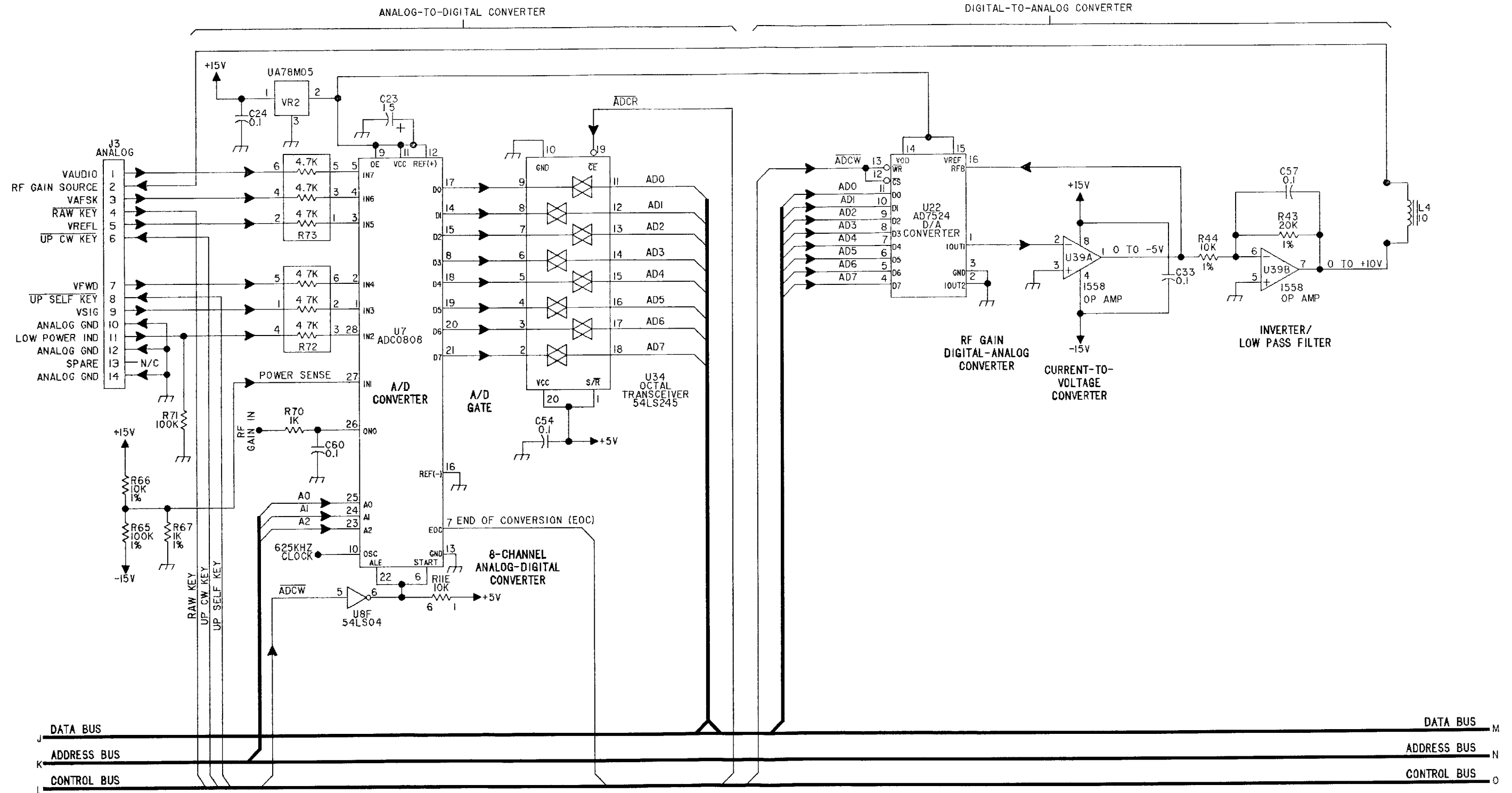

FO-15. TRANSCEIVER CONTROL PWB ASSY, A1A12 (Sheet 6 of 9)



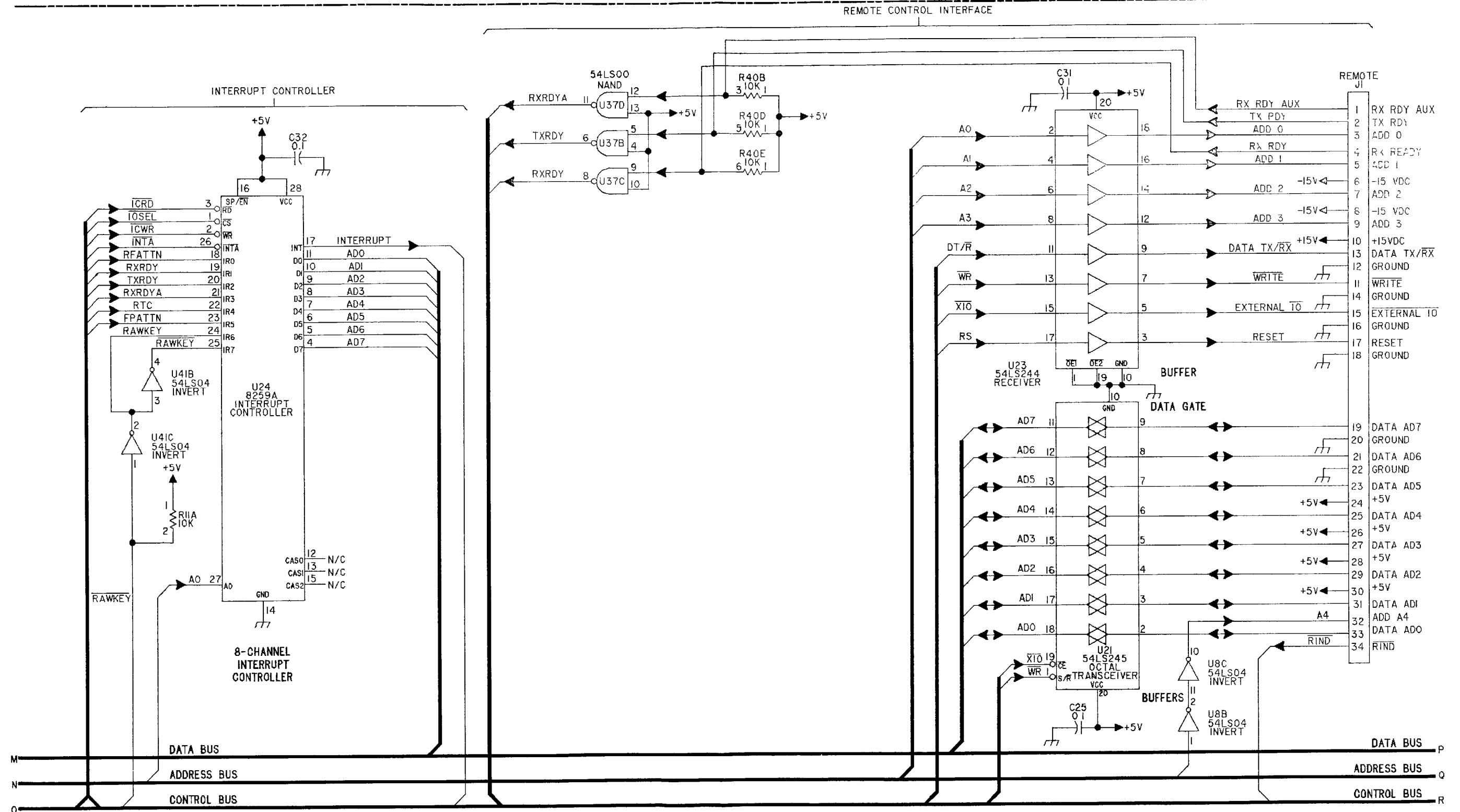

FO-15. TRANSCIVER CONTROL PWB ASSY, A1A12 (Sheet 7 of 9)





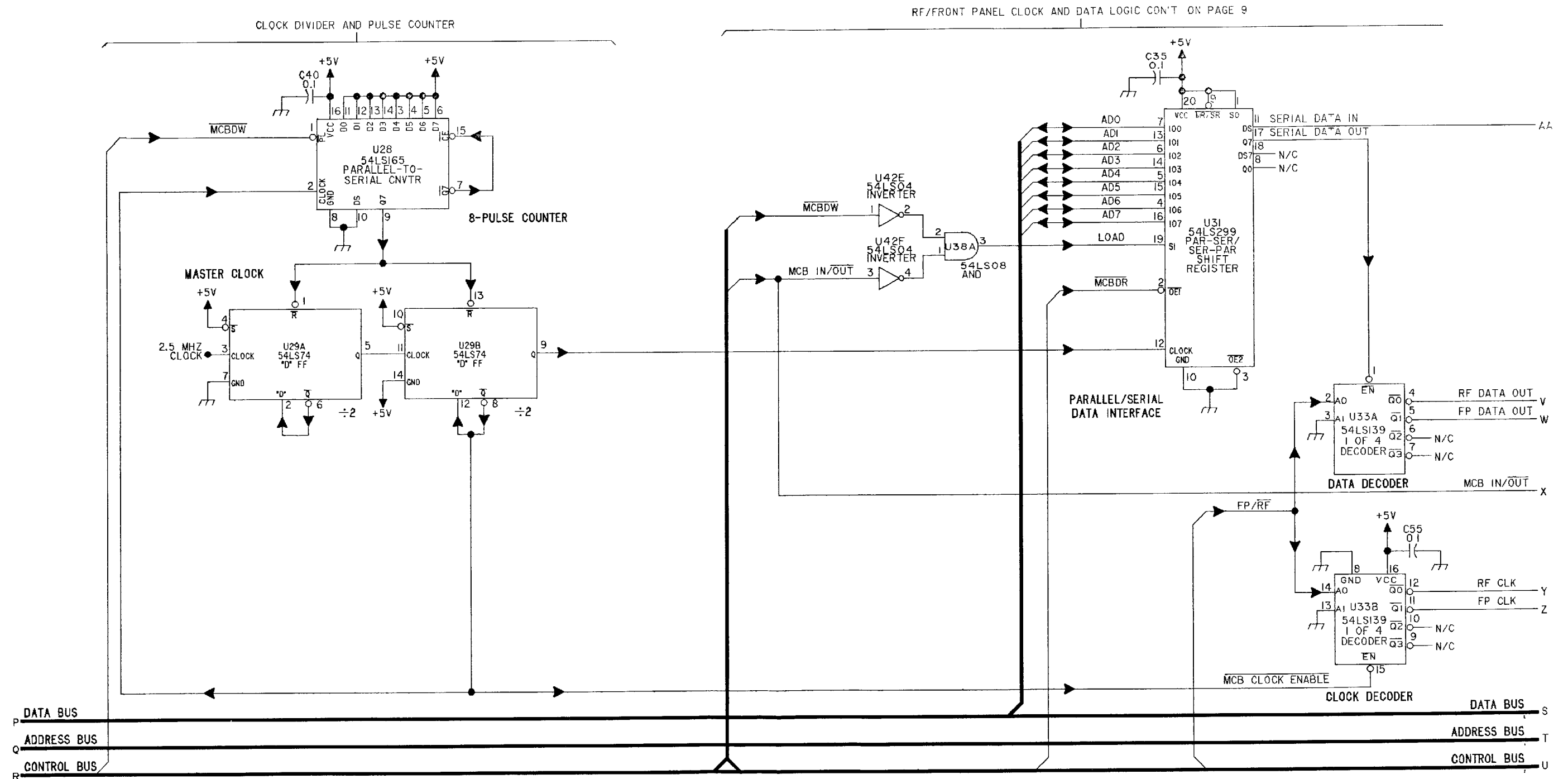



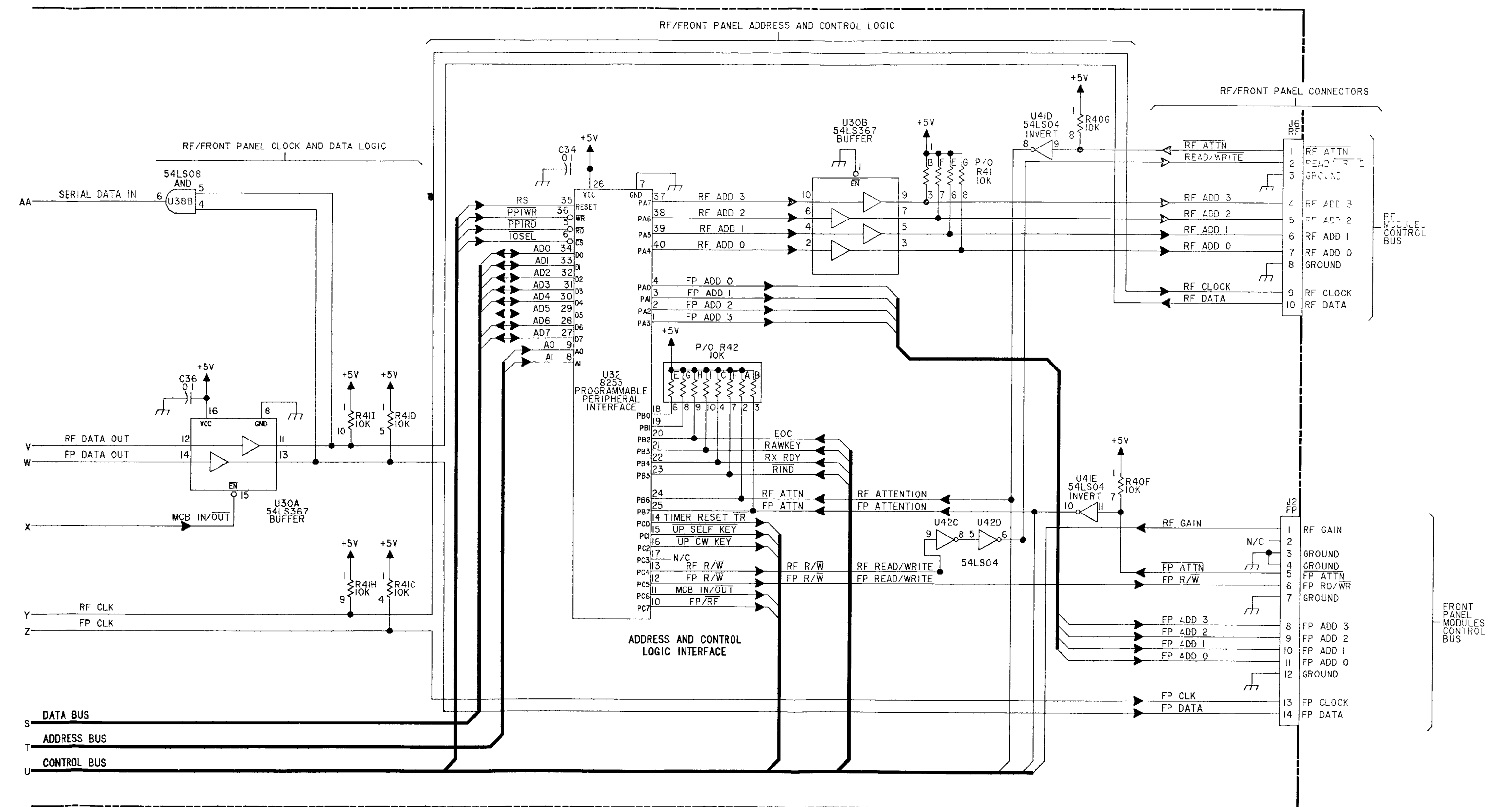

FO-15. TRANSCIVER CONTROL PWB  
 ASSY, A1A12 (Sheet 9 of 9)  
 FP-157/(FP-158 Blank)



NOTE UNLESS OTHERWISE SPECIFIED:

- PARTIAL REFERENCE DESIGNATIONS ARE SHOWN FOR DETAIL PARTS. PREFIX THESE WITH UNIT NO. AND/OR ASSEMBLY DESIGNATIONS SHOWN ON DRAWING TO OBTAIN COMPLETE DESIGNATIONS.
- ALL RESISTOR VALUES ARE IN OHMS. 1/4W. ±5%
- ALL CAPACITOR VALUES ARE IN MICROFARADS (µF).
- ALL INDUCTANCE VALUES ARE IN MICROHENRIES (µH).
- VENDOR PART NO. CALLOUTS ARE FOR REFERENCE ONLY. COMPONENTS ARE SUPPLIED PER PART NO. IN PARTS LIST.
- DC RESISTANCES OF INDUCTIVE ELEMENTS (CHOKES, COILS, MOTOR WINDINGS, ETC.) ARE LESS THAN 1 OHM.
- PANEL DECALS ARE INDICATED BY BOLD TYPE IN A BOLD BOX, E.G. **ON/OFF**.
- ALL RELAYS ARE SHOWN IN THE DE-ENERGIZED STATE.

HIGHEST REFERENCE DESIGNATION			
REFERENCE DESIGNATIONS NOT USED			

UNUSED GATES

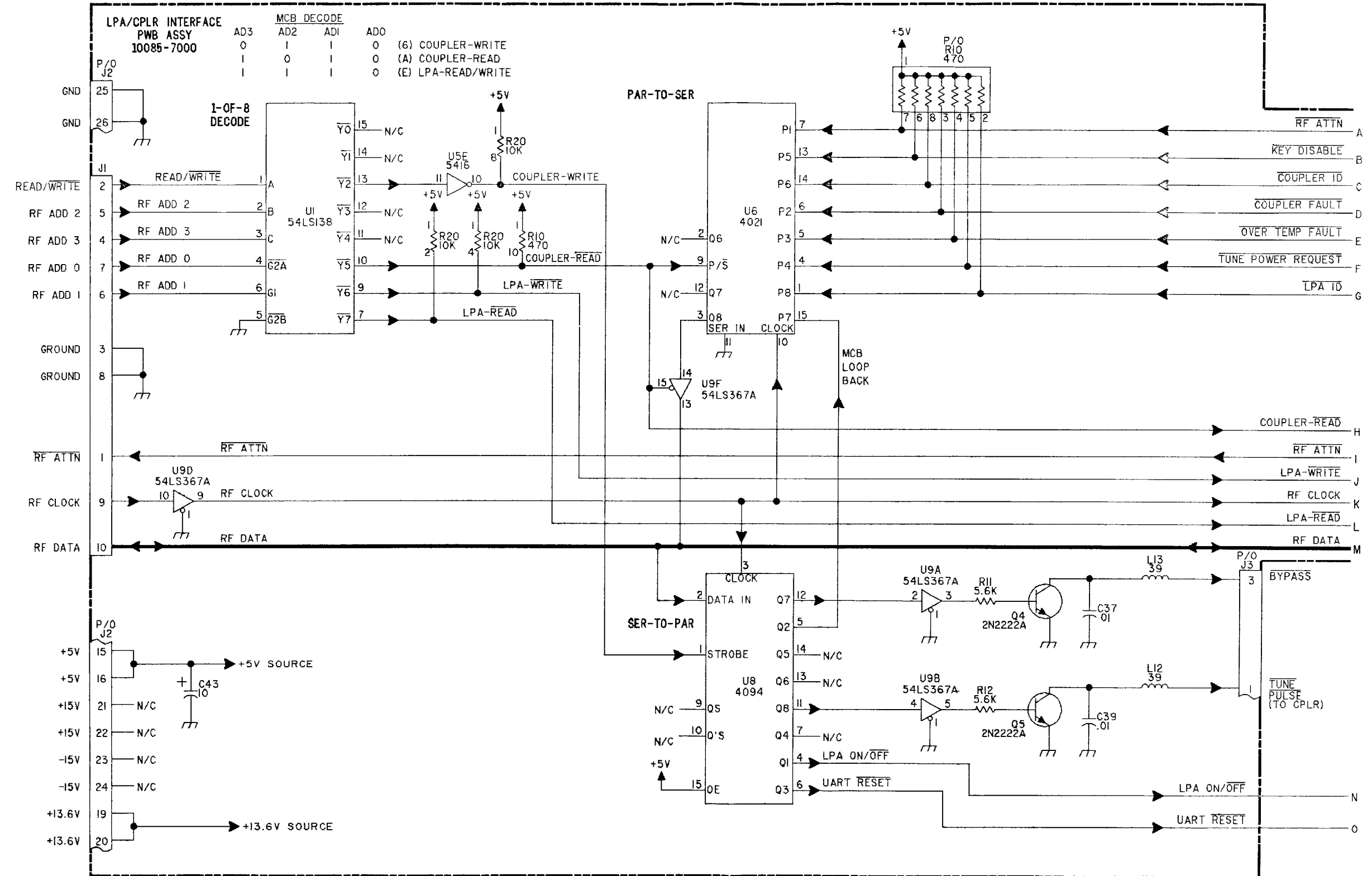
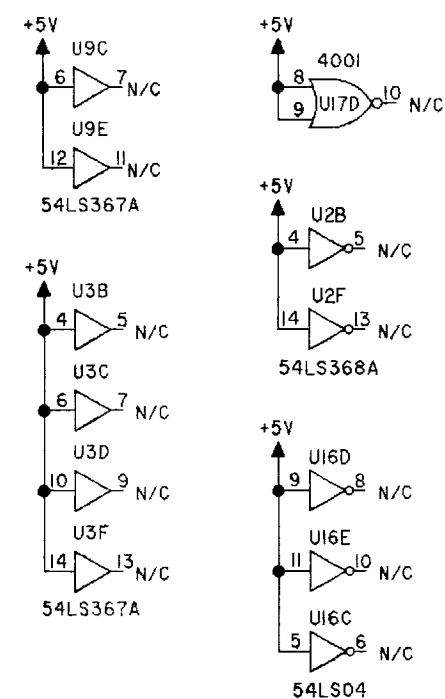

FO-16. LPA/COUPLER INTERFACE PWB ASSY, A1A13 (Sheet 1 of 4)



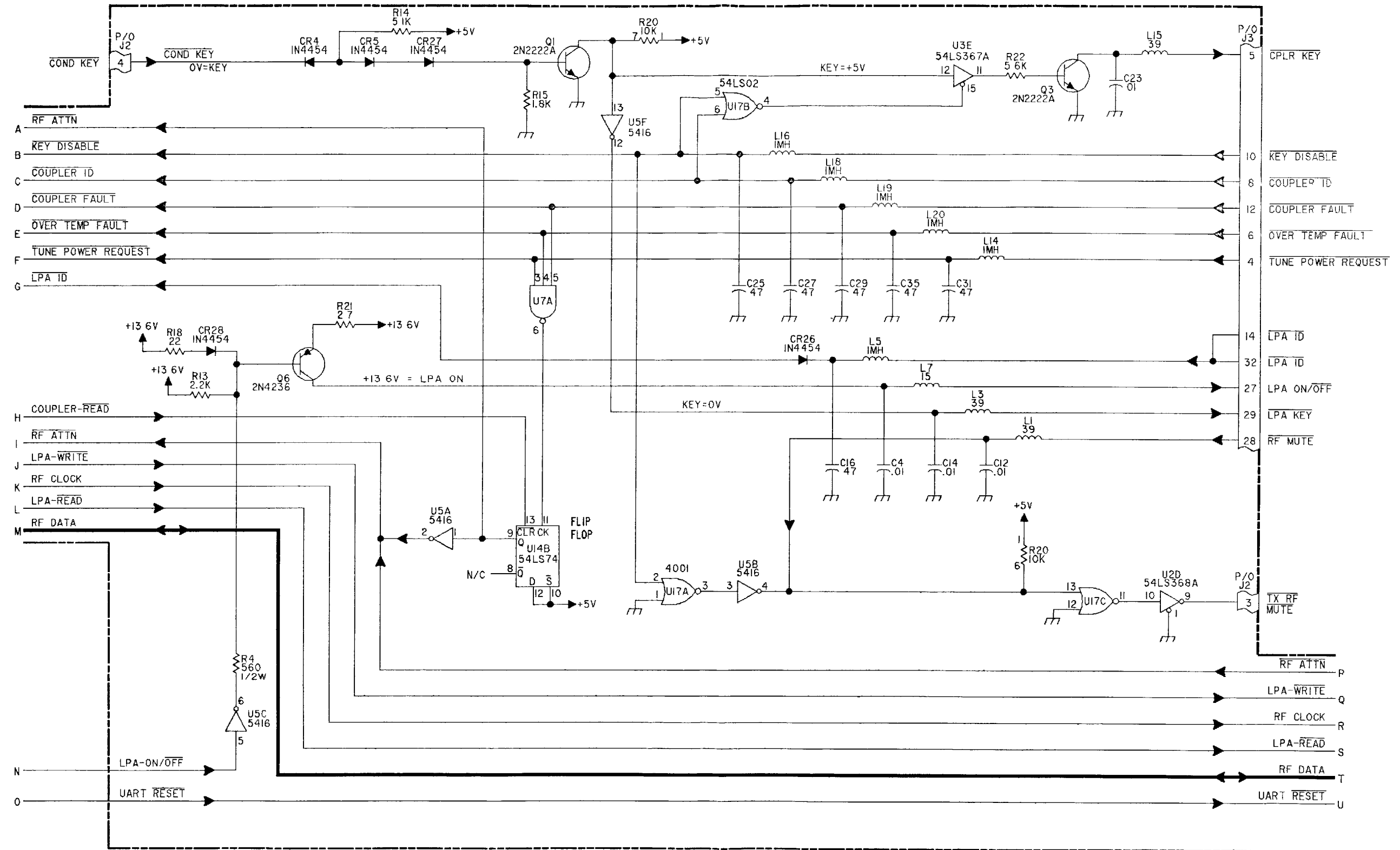

FO-16. LPA/COUPLER INTERFACE PWB ASSY, A1A13 (Sheet 2 of 4)

FP-161(FP-162 Blank)





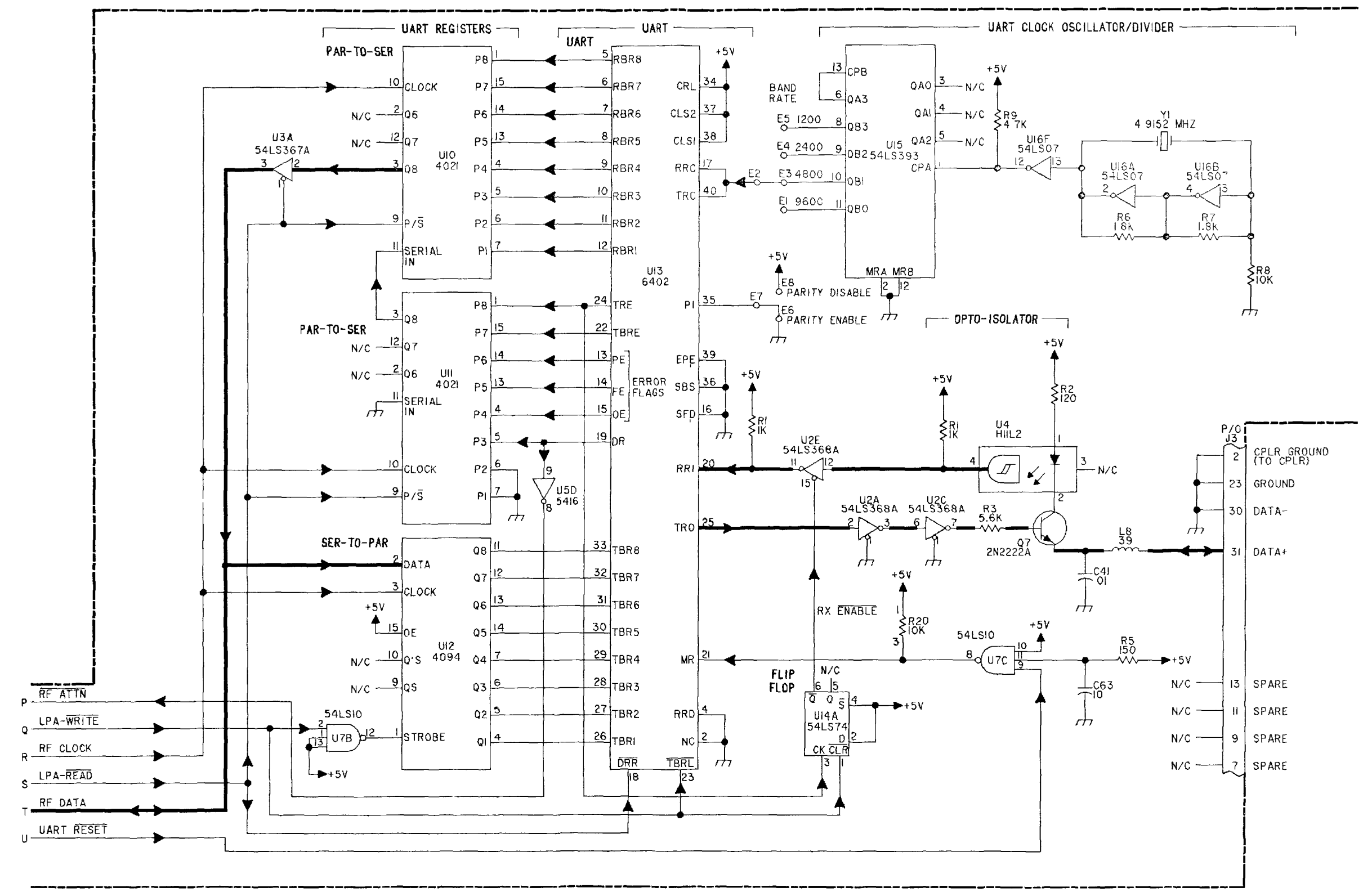

FO-16. LPA/COUPLER INTERFACE PWB ASSY, A1A13 (Sheet 3 of 4)



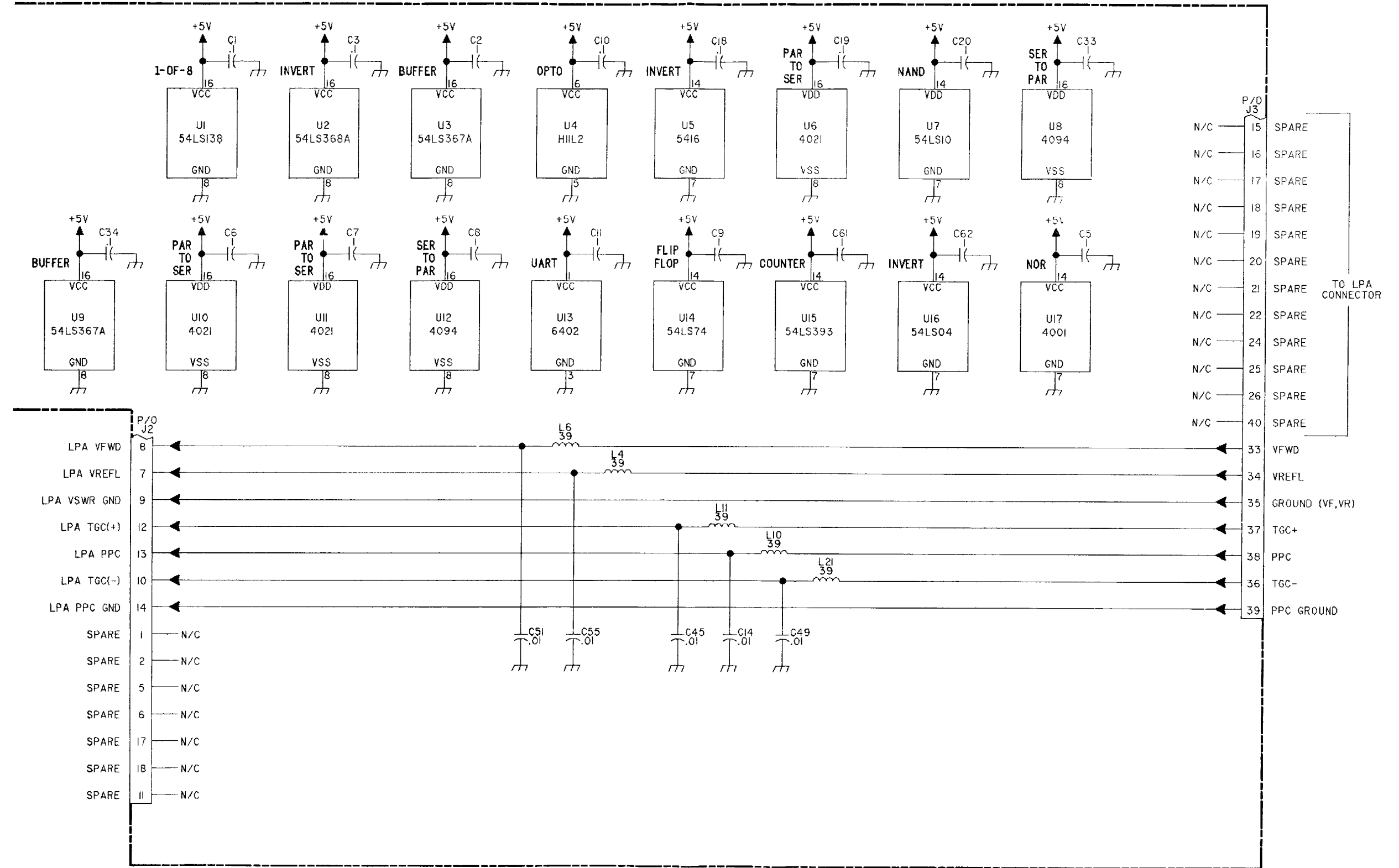

FO-16. LPA/COUPLER INTERFACE PWB ASSY, A1A13 (Sheet 4 of 4)



NOTE UNLESS OTHERWISE SPECIFIED:

1. PARTIAL REFERENCE DESIGNATIONS ARE SHOWN FOR DETAIL PARTS. PREFIX THESE WITH UNIT NO. AND/OR ASSEMBLY DESIGNATIONS SHOWN ON DRAWING TO OBTAIN COMPLETE DESIGNATIONS.
2. ALL RESISTOR VALUES ARE IN OHMS, 1/4W, ±5%
3. ALL CAPACITOR VALUES ARE IN MICROFARADS (µF).
4. ALL INDUCTANCE VALUES ARE IN MICROHENRIES (µH)
5. VENDOR PART NO. CALLOUTS ARE FOR REFERENCE ONLY. COMPONENTS ARE SUPPLIED PER PART NO. IN PARTS LIST
6. DC RESISTANCES OF INDUCTIVE ELEMENTS (CHOKES, COILS, MOTOR WINDINGS, ETC.) ARE LESS THAN 1 OHM.
7. PANEL DECALS ARE INDICATED BY BOLD TYPE IN A BOLD BOX, E.G., **ON/OFF**.
8. ALL RELAYS ARE SHOWN IN THE DE-ENERGIZED STATE.

HIGHEST REFERENCE DESIGNATION	
REFERENCE DESIGNATIONS NOT USED	

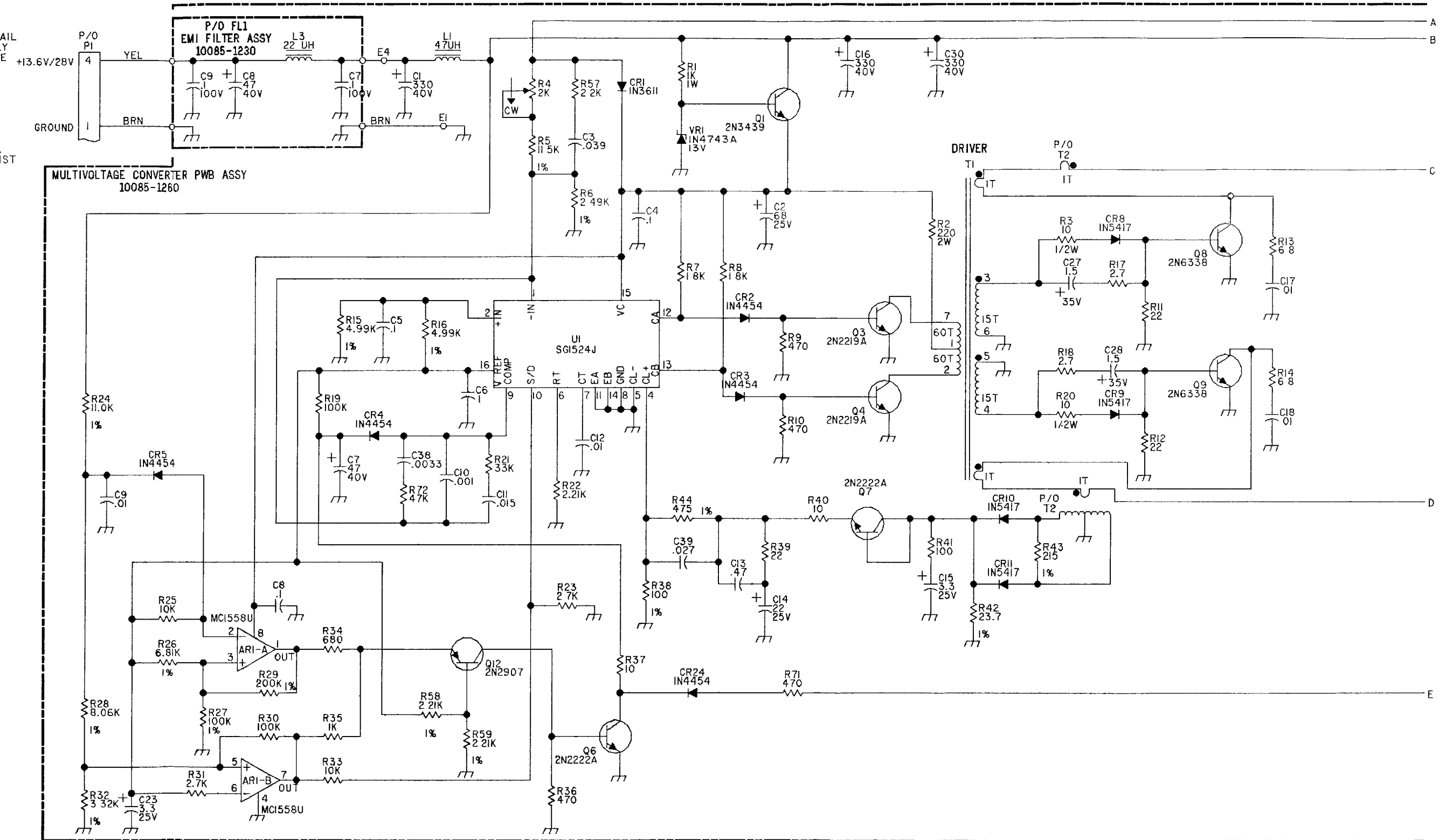

FO-17. MULTIVOLTAGE SUPPLY PWB ASSY, A1A14A1 (Sheet 1 of 2)



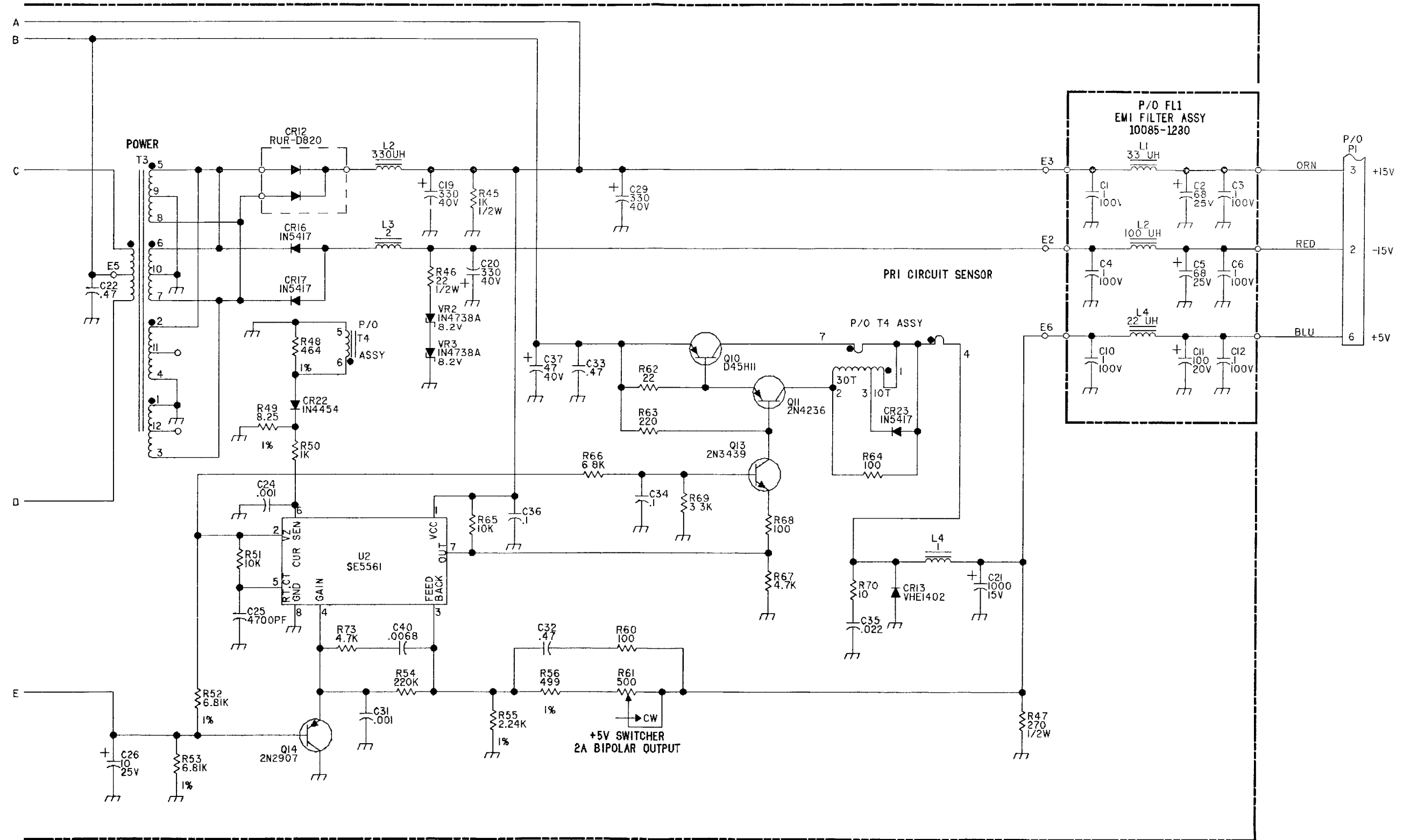

FO-17. MULTIVOLTAGE SUPPLY PWB ASSY, A1A14A1 (Sheet 2 of 2)





NOTE: UNLESS OTHERWISE SPECIFIED:

- PARTIAL REFERENCE DESIGNATIONS ARE SHOWN FOR DETAIL PARTS. PREFIX THESE WITH UNIT NO AND/OR ASSEMBLY DESIGNATIONS SHOWN ON DRAWING TO OBTAIN COMPLETE DESIGNATIONS
- VENDOR PART NO. CALLOUTS ARE FOR REFERENCE ONLY. COMPONENTS ARE SUPPLIED PER PART NO. IN PARTS LIST
- PANEL DECALS ARE INDICATED BY BOLD TYPE IN A BOLD BOX, E.G., **ON/OFF**

HIGHEST REFERENCE DESIGNATION	
REFERENCE DESIGNATIONS NOT USED	

*A MULTIPLE ROUTE SIGNALS		
SIGNAL	ORIGIN	TERMINATIONS
COND KEY	J7-3	J6-16, J8-10, P3-3, P13-4
+15R	P6-8	P1-8, P3-4, P9-28, P11-38, P12-22
+15T	P6-7	P1-7, P9-27, P11-37, P12-21

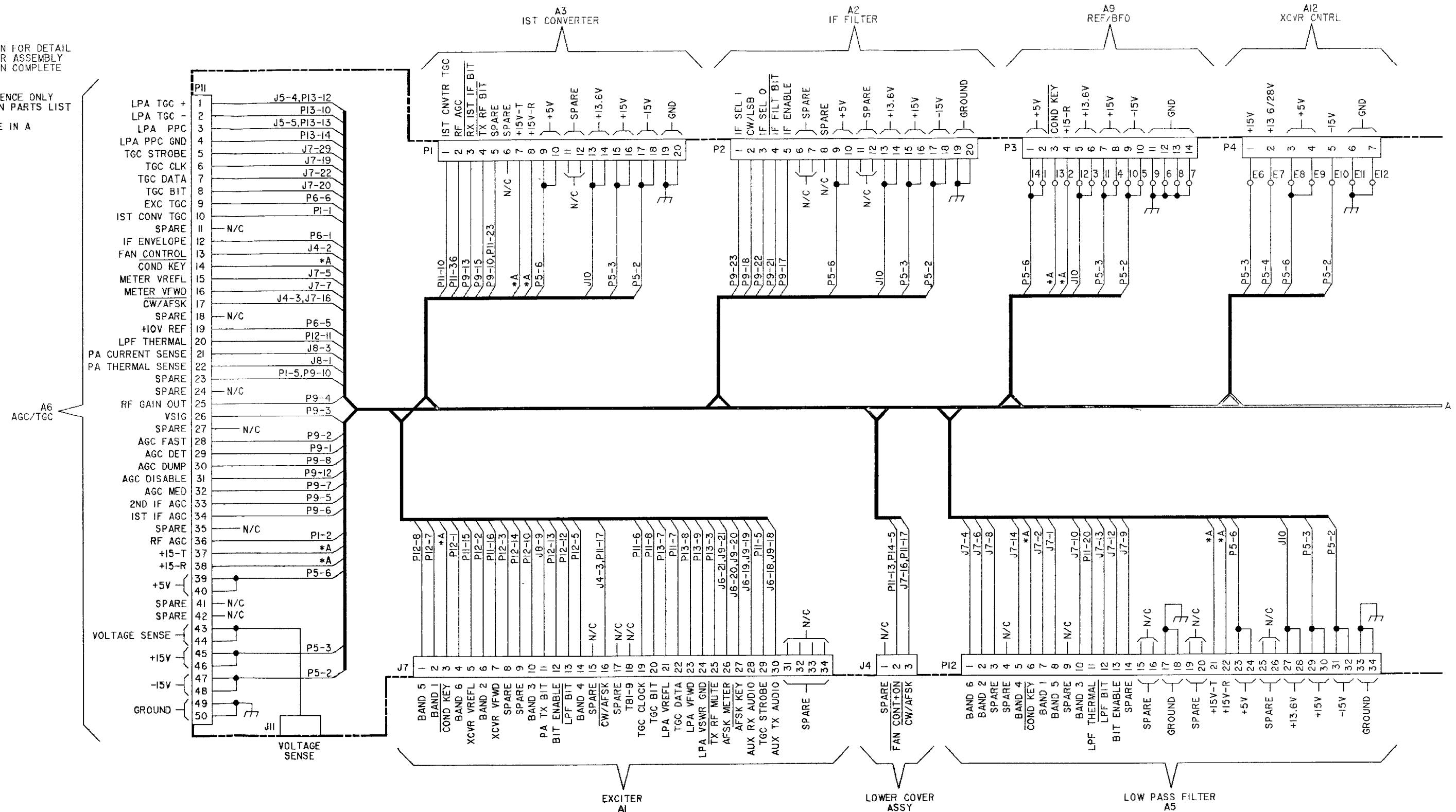

FO-18. INTERCONNECT PWB ASSY, A1A15 (Sheet 1 of 3)

FP-171/(FP-172 Blank)



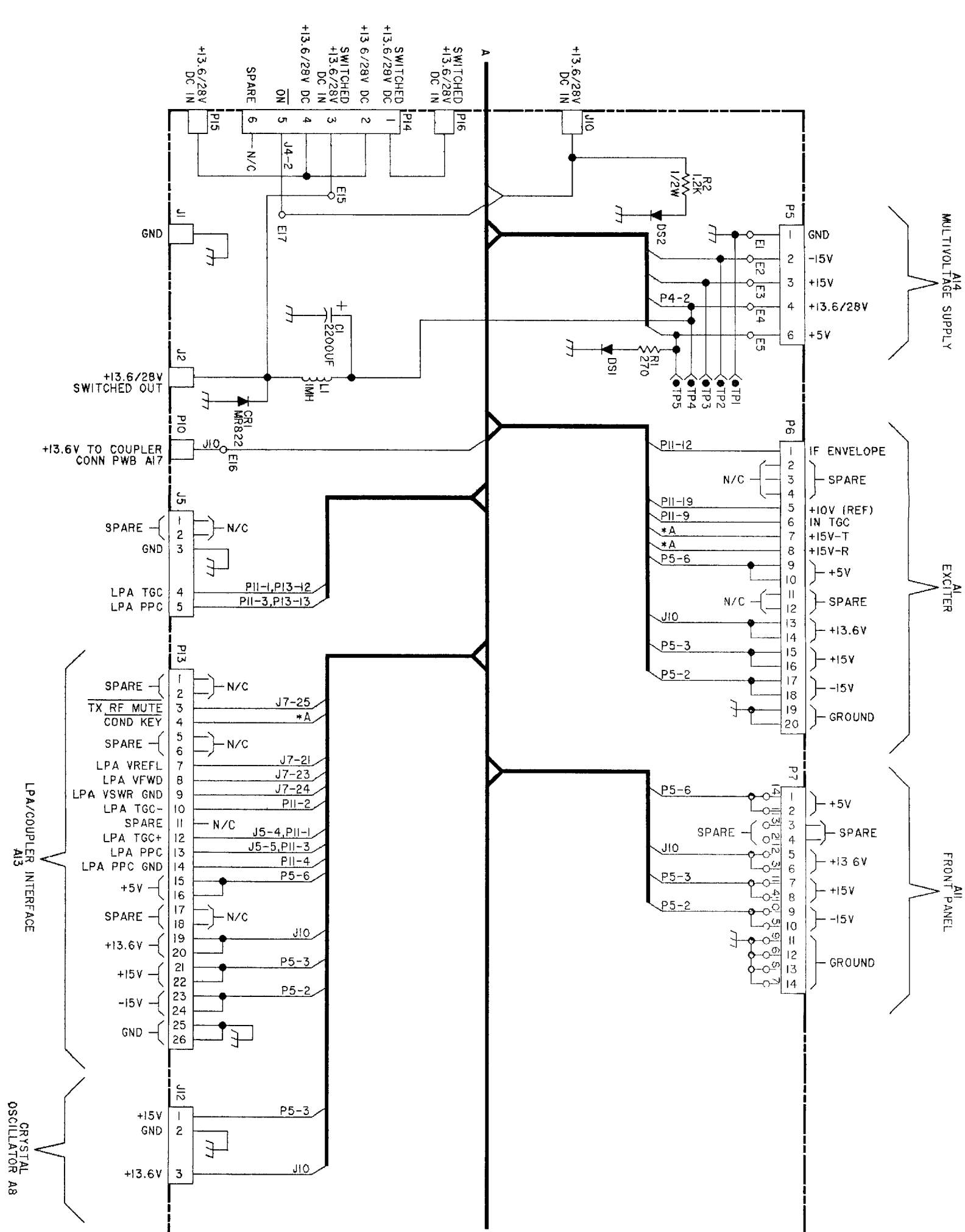

FO-18. INTERCONNECT PWB ASSY, A1A15  
(Sheet 2 of 3)

FP-173/(FP-174 Blank)



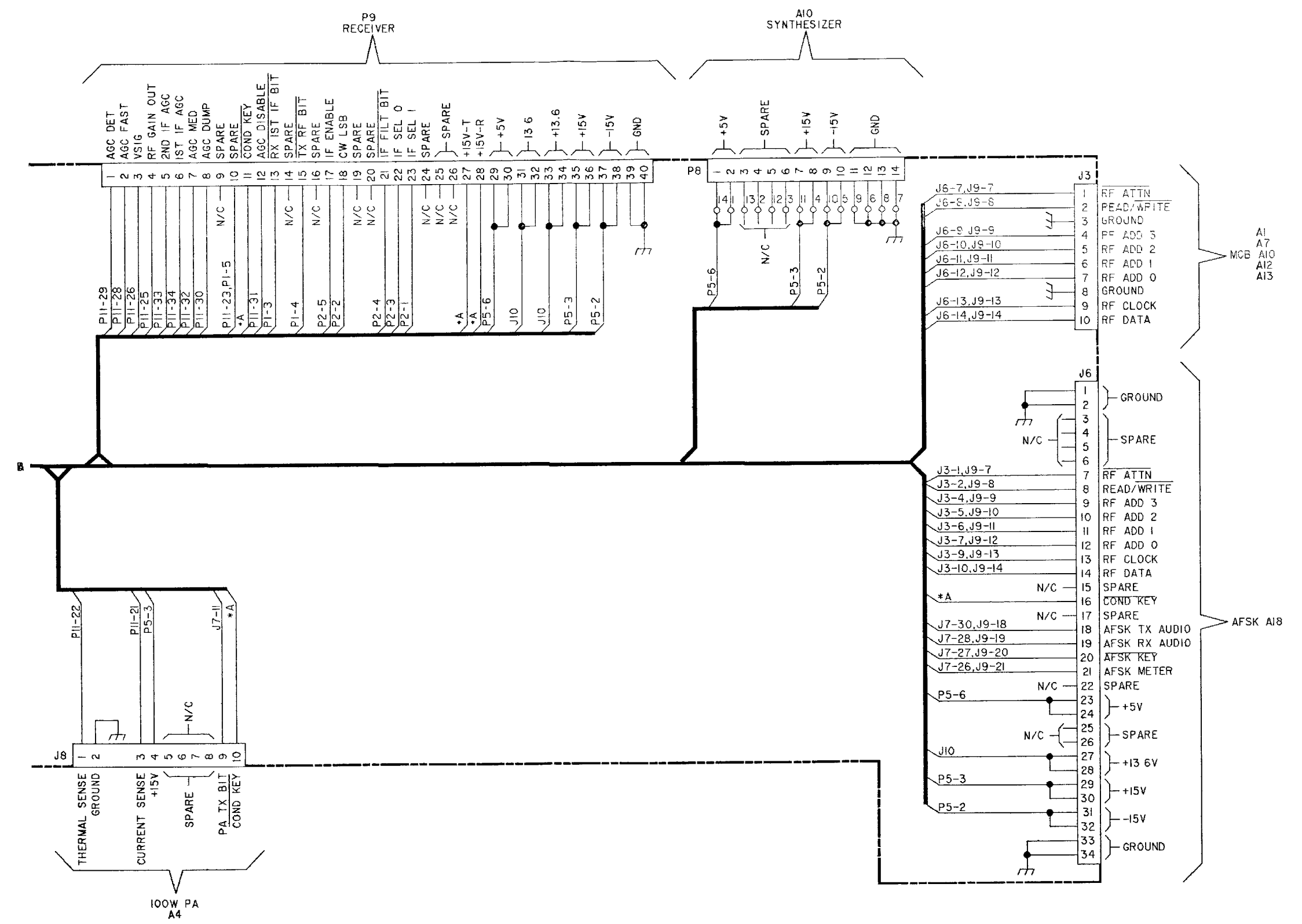

FO-18. INTERCONNECT PWB ASSY, A1A15 (Sheet 3 of 3)

FP-175/(FP-176 Blank)



NOTE UNLESS OTHERWISE SPECIFIED

- 1 PARTIAL REFERENCE DESIGNATIONS ARE SHOWN FOR DETAIL PARTS PREFIX THESE WITH UNIT NO AND/OR ASSEMBLY DESIGNATIONS SHOWN ON DRAWING TO OBTAIN COMPLETE DESIGNATIONS
- 2 ALL RESISTOR VALUES ARE IN OHMS, 1/4W, 15%
- 3 ALL CAPACITOR VALUES ARE IN MICROFARADS (uF)
- 4 ALL INDUCTANCE VALUES ARE IN MICROHENRIES (uH)
- 5 VENDOR PART NO CALLOUTS ARE FOR REFERENCE ONLY COMPONENTS ARE SUPPLIED PER PART NO IN PARTS LIST
- 6 DC RESISTANCES OF INDUCTIVE ELEMENTS (CHOKES, COILS, MOTOR WINDINGS, ETC.) ARE LESS THAN 1 OHM
- 7 PANEL DECALS ARE INDICATED BY BOLD TYPE IN A BOLD BOX, E.G., **ON/OFF**
- 8 ALL RELAYS ARE SHOWN IN THE DE-ENERGIZED STATE

HIGHEST REFERENCE DESIGNATION	
REFERENCE DESIGNATIONS NOT USED	

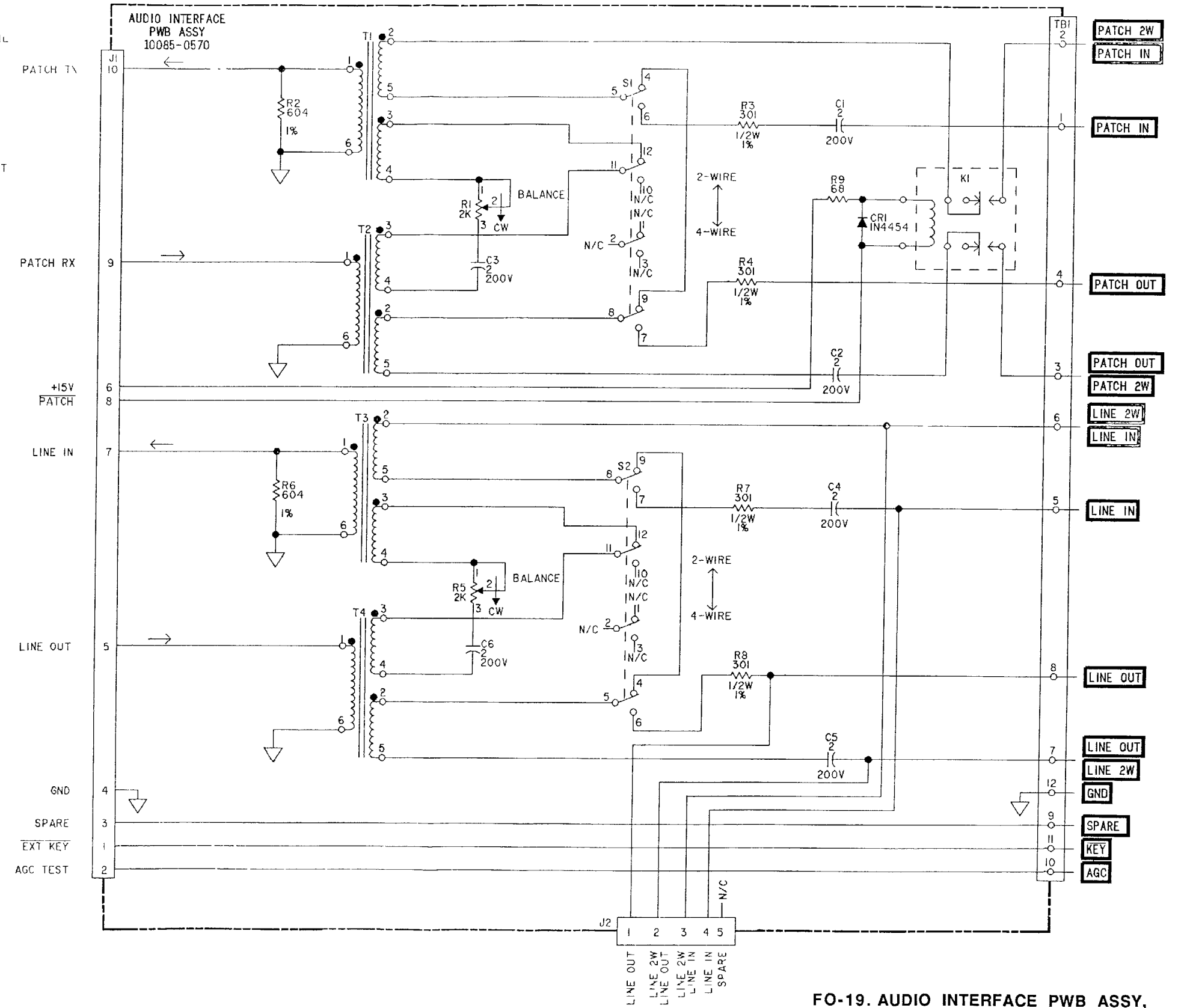

FO-19. AUDIO INTERFACE PWB ASSY, A1A16





NOTE UNLESS OTHERWISE SPECIFIED

- 1 PARTIAL REFERENCE DESIGNATIONS ARE SHOWN FOR DETAIL PARTS. PREFIX THESE WITH UNIT NO. AND/OR ASSEMBLY DESIGNATIONS SHOWN ON DRAWING TO OBTAIN COMPLETE DESIGNATIONS.
- 2 ALL RESISTOR VALUES ARE IN OHMS, 1/4W. ±5%
- 3 ALL CAPACITOR VALUES ARE IN MICROFARADS (UF)
4. ALL INDUCTANCE VALUES ARE IN MILLIHENRIES (MH).
5. VENDOR PART NO. CALLOUTS ARE FOR REFERENCE ONLY. COMPONENTS ARE SUPPLIED PER PART NO. IN PARTS LIST
6. DC RESISTANCES OF INDUCTIVE ELEMENTS (CHOKES, COILS, MOTOR WINDINGS, ETC.) ARE LESS THAN 1 OHM.
7. PANEL DECALS ARE INDICATED BY BOLD TYPE IN A BOLD BOX, E.G., **ON/OFF**
8. ALL RELAYS ARE SHOWN IN THE DE-ENERGIZED STATE.

HIGHEST REFERENCE DESIGNATION			
REFERENCE DESIGNATIONS NOT USED			

TO J3  
LPA/COUPLER  
INTERFACE PWB  
A1A13  
10085-7000

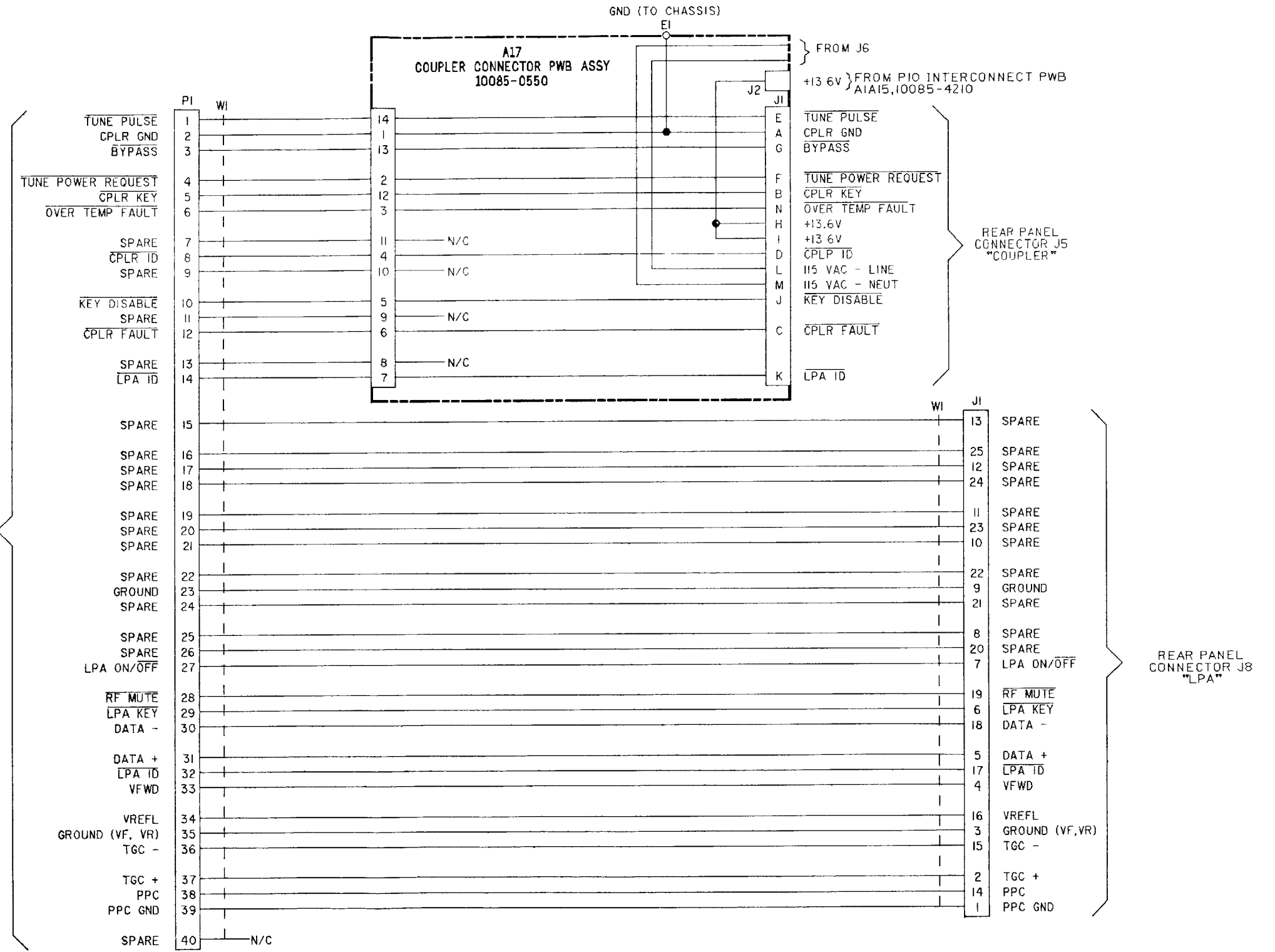

FO-20. COUPLER CONNECTOR PWB ASSY, A1A17



NOTE: UNLESS OTHERWISE SPECIFIED:

- 1. PARTIAL REFERENCE DESIGNATIONS ARE SHOWN FOR DETAIL PARTS. PREFIX THESE WITH UNIT NO AND/OR ASSEMBLY DESIGNATIONS SHOWN ON DRAWING TO OBTAIN COMPLETE DESIGNATIONS.
- 2. ALL RESISTOR VALUES ARE IN OHMS, 1/4W, ±5%
- 3. ALL CAPACITOR VALUES ARE IN MICROFARADS (µF).
- 4. ALL INDUCTANCE VALUES ARE IN MICROHENRIES (µH)
- 5. VENDOR PART NO. CALLOUTS ARE FOR REFERENCE ONLY. COMPONENTS ARE SUPPLIED PER PART NO. IN PARTS LIST
- 6. DC RESISTANCES OF INDUCTIVE ELEMENTS (CHOKES, COILS, MOTOR WINDINGS, ETC.) ARE LESS THAN 1 OHM.
- 7. PANEL DECALS ARE INDICATED BY BOLD TYPE IN A BOLD BOX, E.G. **ON/OFF**
- 8. ALL RELAYS ARE SHOWN IN THE DE-ENERGIZED STATE.

HIGHEST REFERENCE DESIGNATION	
REFERENCE DESIGNATIONS NOT USED	

UNUSED GATES

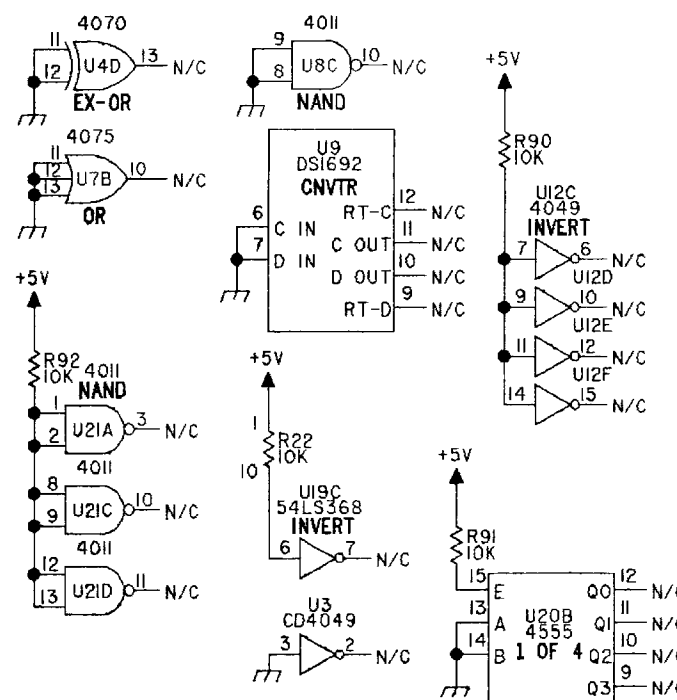

UNUSED GATES

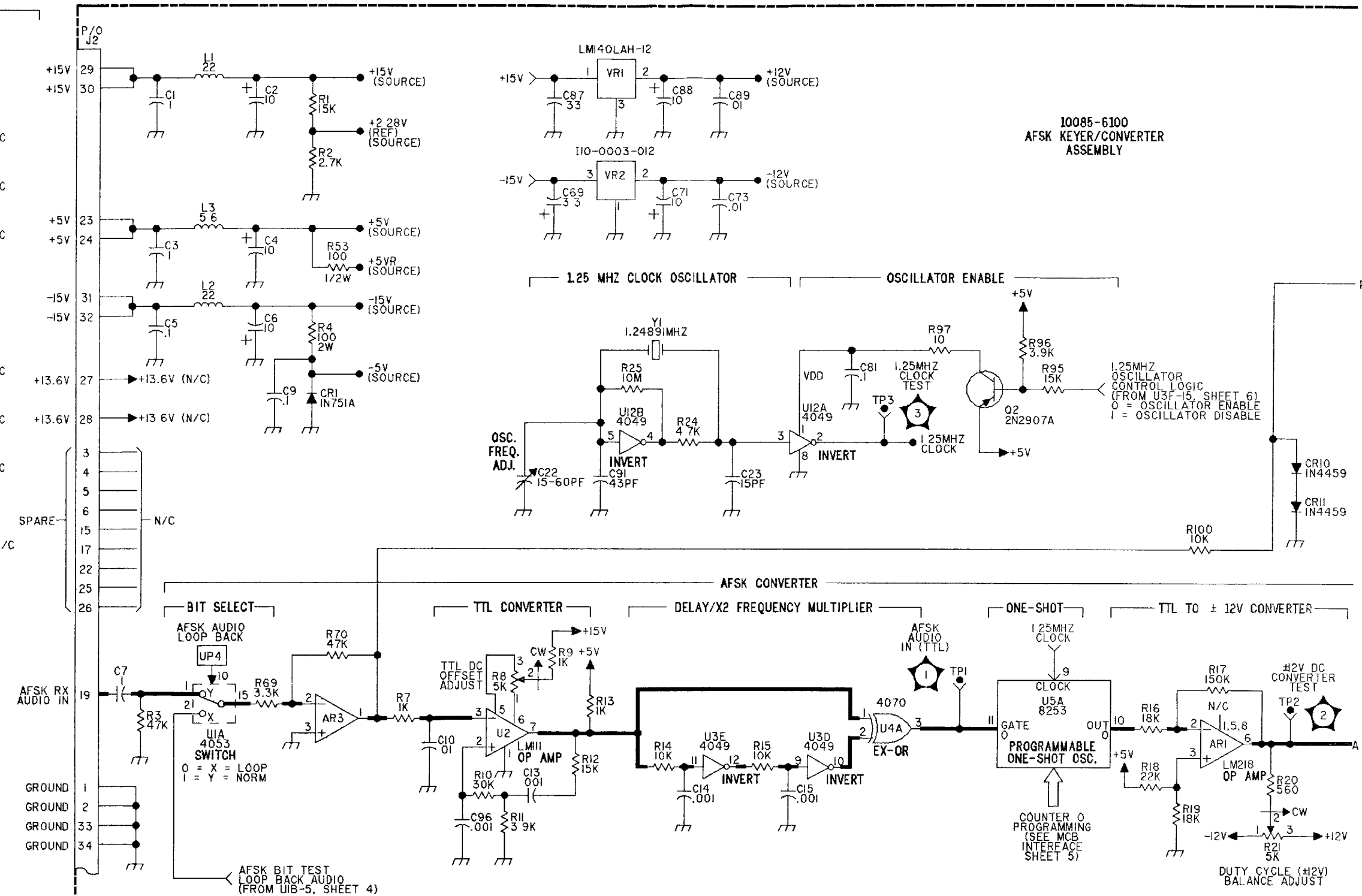
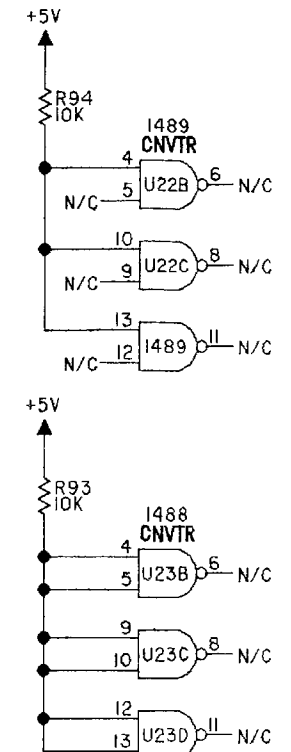

FO-21. AFSK MODULE ASSY, A1A18 (Sheet 1 of 6)



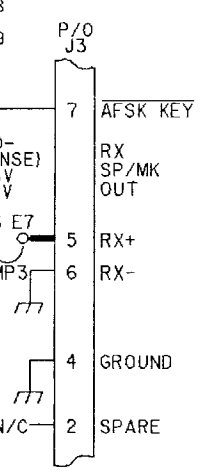
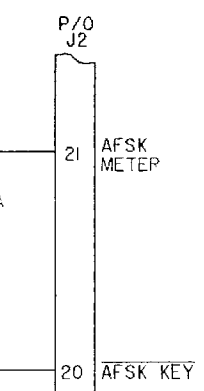
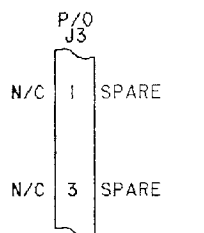
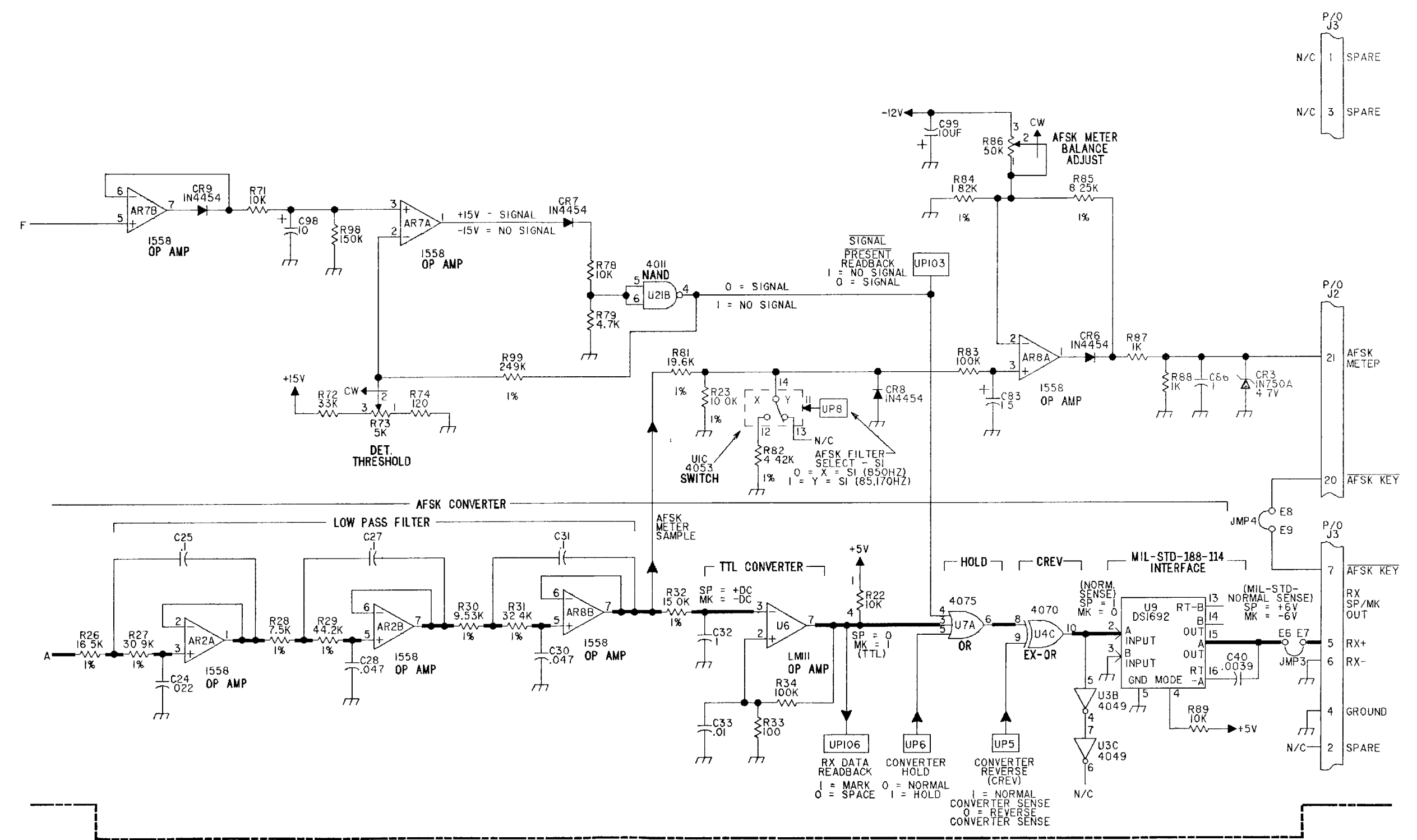

FO-21. AFSK MODULE ASSY, A1A18  
(Sheet 2 of 6)



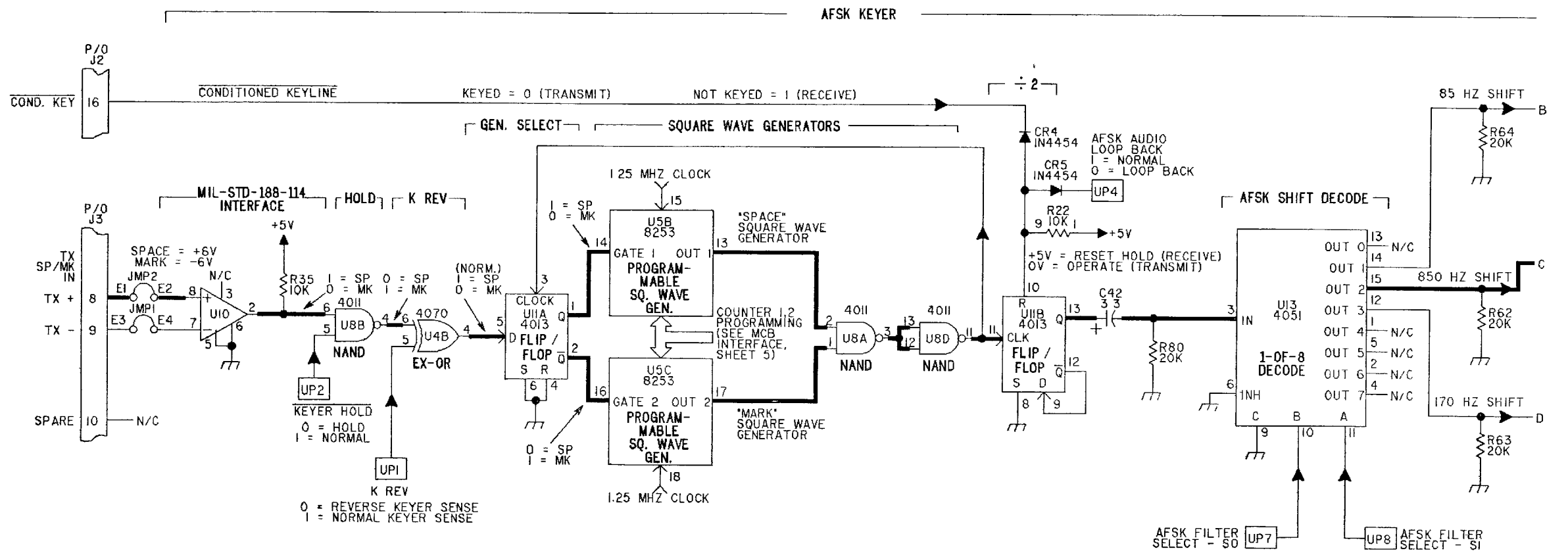

FO-21. AFSK MODULE ASSY, A1A18  
(Sheet 3 of 6)





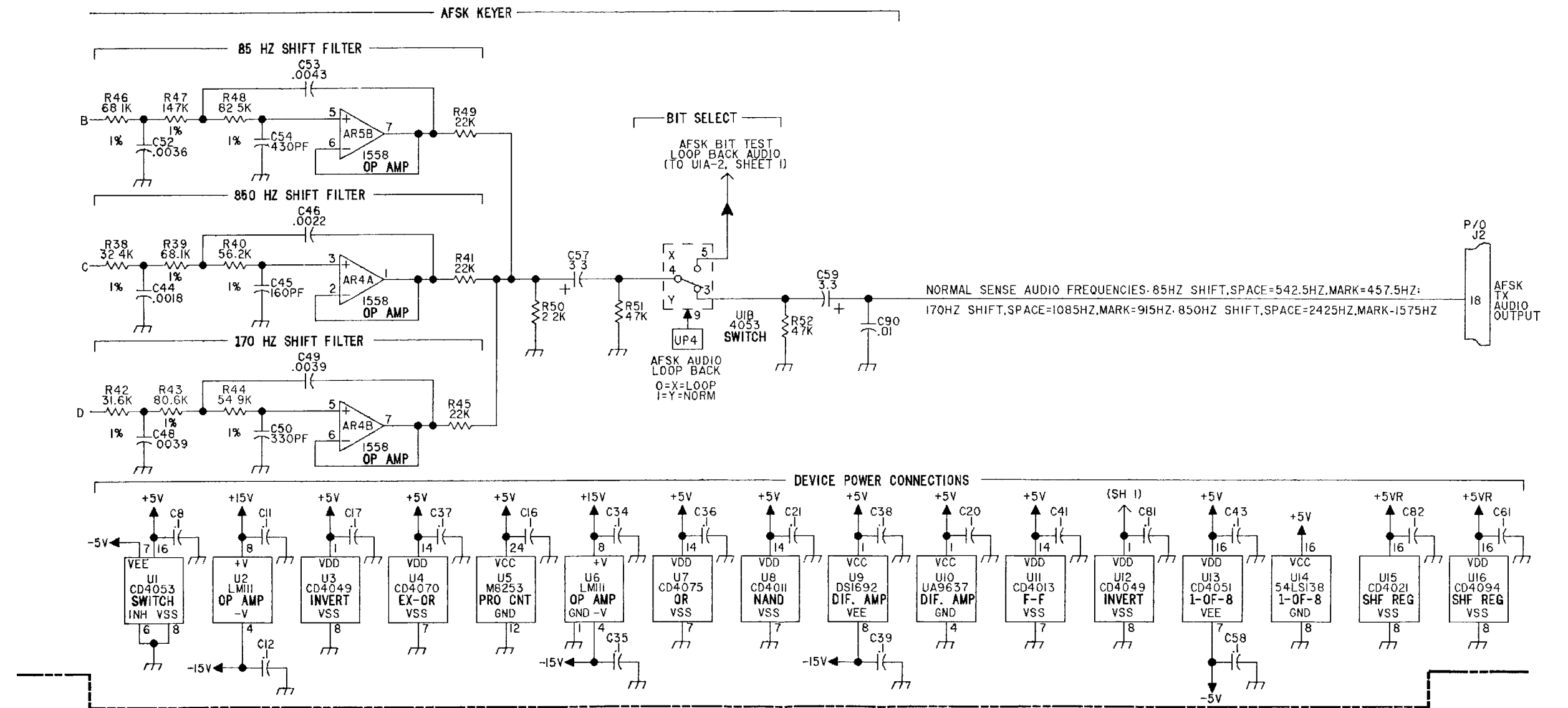

FO-21. AFSK MODULE ASSY, A1A18  
(Sheet 4 of 6)



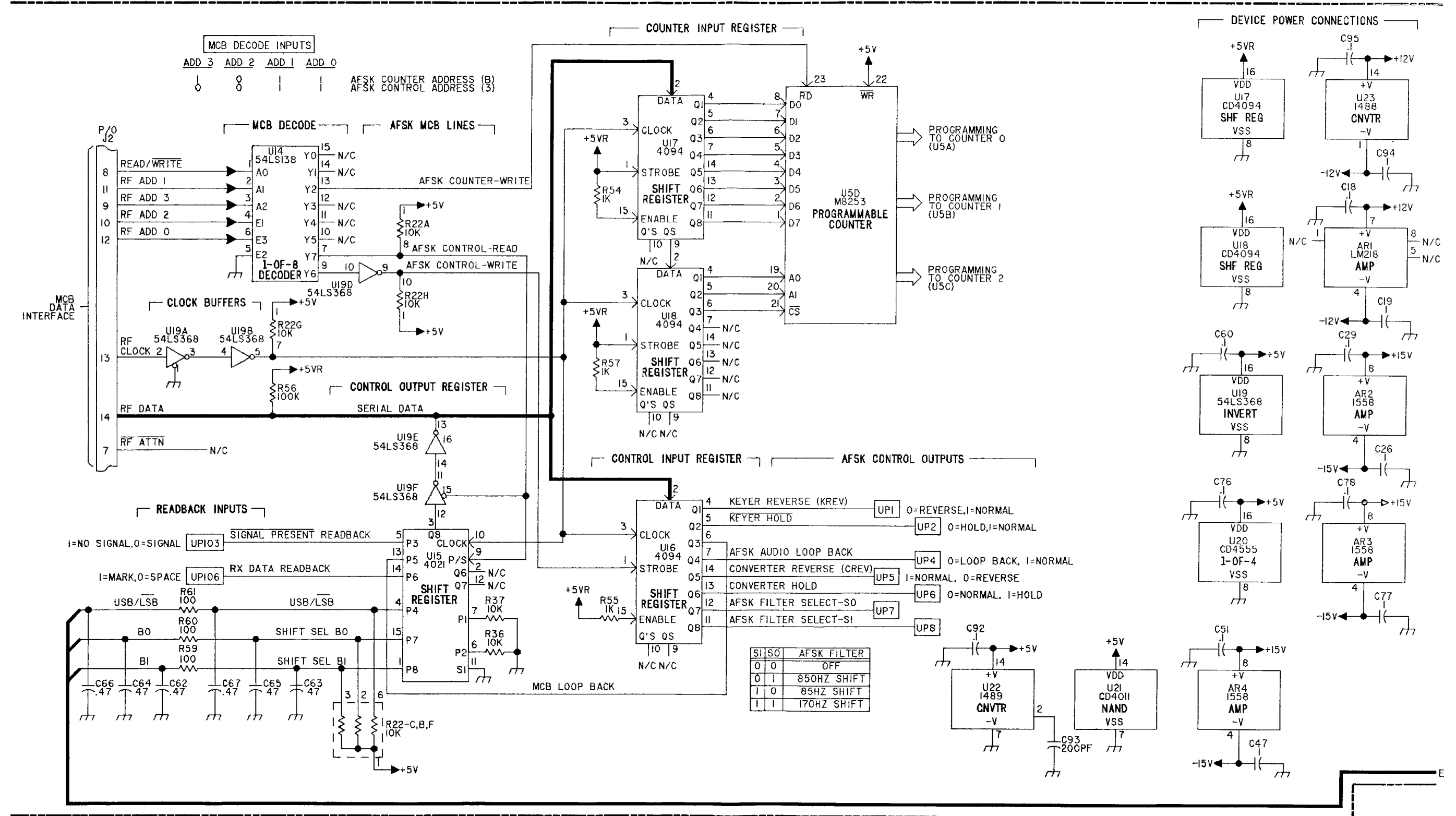

FO-21. AFSK MODULE ASSY, A1A18  
(Sheet 5 of 6)



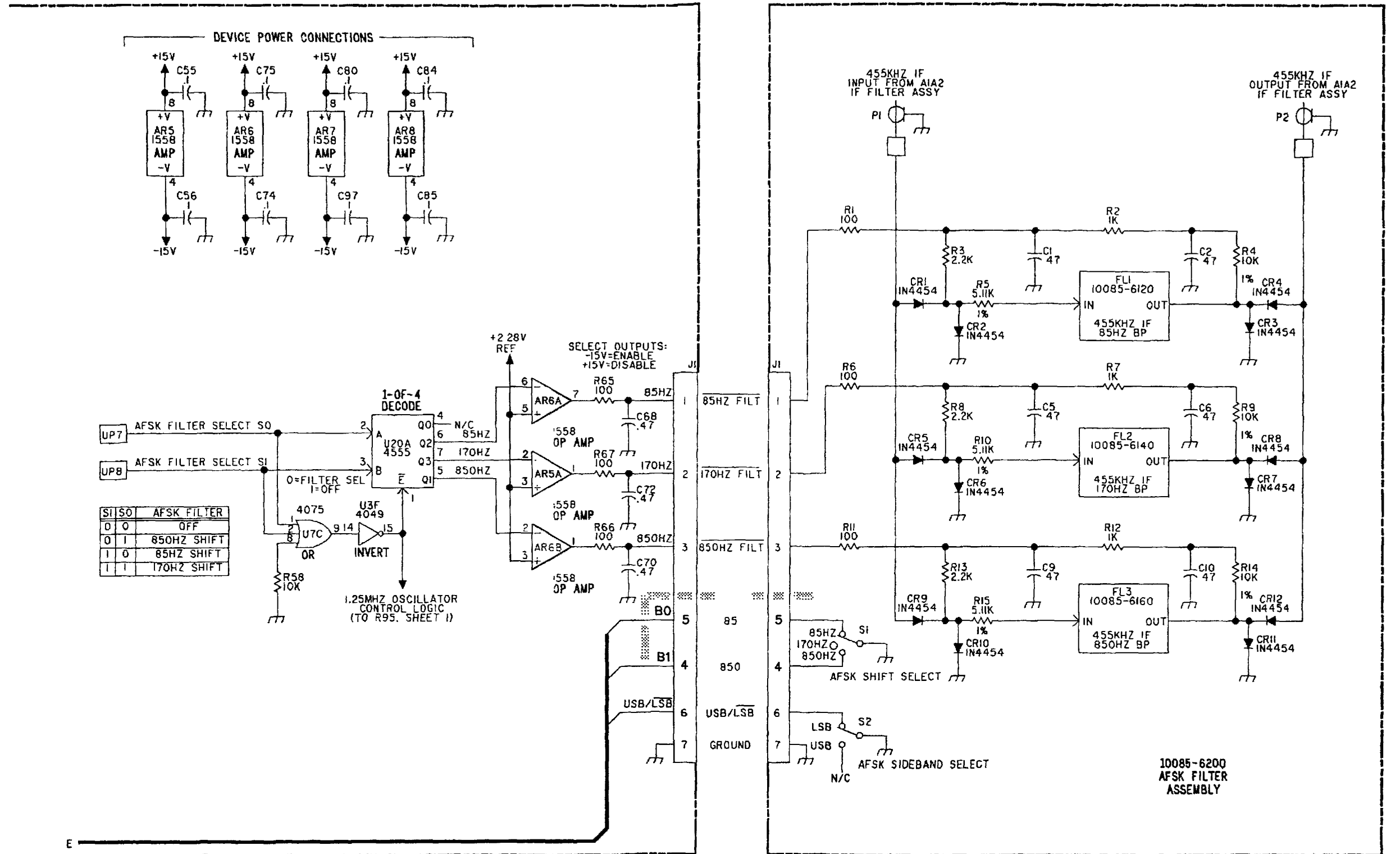



NOTE: UNLESS OTHERWISE SPECIFIED:

1. PARTIAL REFERENCE DESIGNATIONS ARE SHOWN FOR DETAIL PARTS. PREFIX THESE WITH UNIT NO AND/OR ASSEMBLY DESIGNATIONS SHOWN ON DRAWING TO OBTAIN COMPLETE DESIGNATIONS
2. ALL RESISTOR VALUES ARE IN OHMS, 1/4W, ±5%.
3. ALL CAPACITOR VALUES ARE IN MICROFARADS (UF)
4. ALL INDUCTANCE VALUES ARE IN MILLIHENRIES (MH)
5. VENDOR PART NO. CALLOUTS ARE FOR REFERENCE ONLY. COMPONENTS ARE SUPPLIED PER PART NO IN PARTS LIST
6. DC RESISTANCES OF INDUCTIVE ELEMENTS (CHOKES, COILS, MOTOR WINDINGS, ETC.) ARE LESS THAN 1 OHM.
7. PANEL DECALS ARE INDICATED BY BOLD TYPE IN A BOLD BOX, E.G. **ON/OFF**
8. ALL RELAYS ARE SHOWN IN THE DE-ENERGIZED STATE

HIGHEST REFERENCE DESIGNATION			

REFERENCE DESIGNATIONS NOT USED			

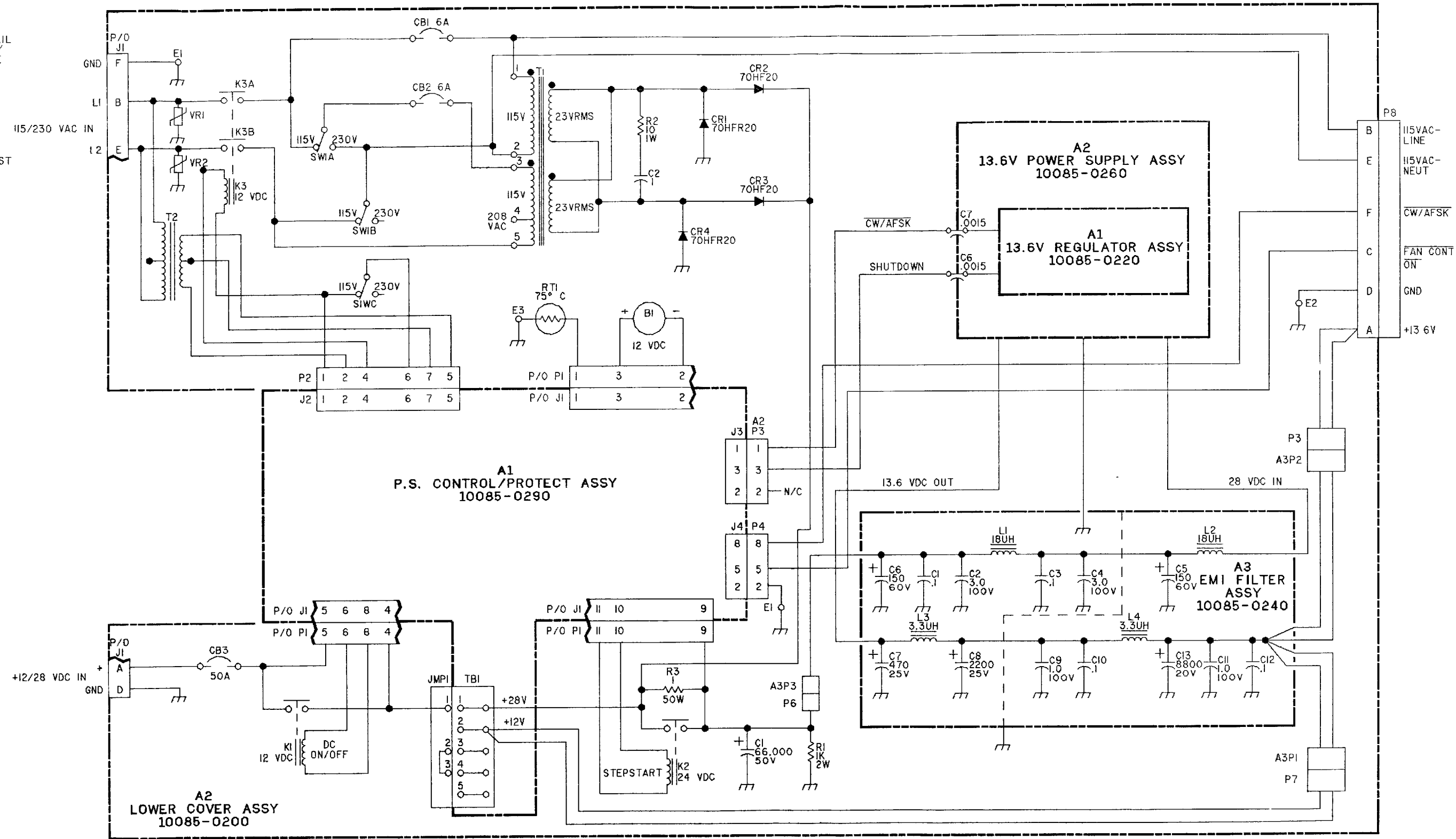

FO-22. POWER SUPPLY ASSY, A2  
FP-193/(FP-194 Blank)





NOTE: UNLESS OTHERWISE SPECIFIED:

1. PARTIAL REFERENCE DESIGNATIONS ARE SHOWN FOR A COMPLETE DESIGNATION. PREFIX WITH UNIT NO. AND/OR ASSEMBLY NO. DESIGNATION.
2. ALL RESISTOR VALUES ARE IN OHMS, 1/4W, ±5%.
3. ALL CAPACITOR VALUES ARE IN MICROFARADS.
4. VENDOR PART NO. CALLOUTS ARE FOR REFERENCE ONLY. COMPONENTS ARE SUPPLIED PER PART NO. IN PARTS LIST.

HIGHEST REFERENCE DESIGNATION			
ARI	C10	CR31	DS3 J4
I1	Q17	R58	TBI

REFERENCE DESIGNATIONS NOT USED			
R1	R27	R39	CR17/CR18
CR21	CR22		

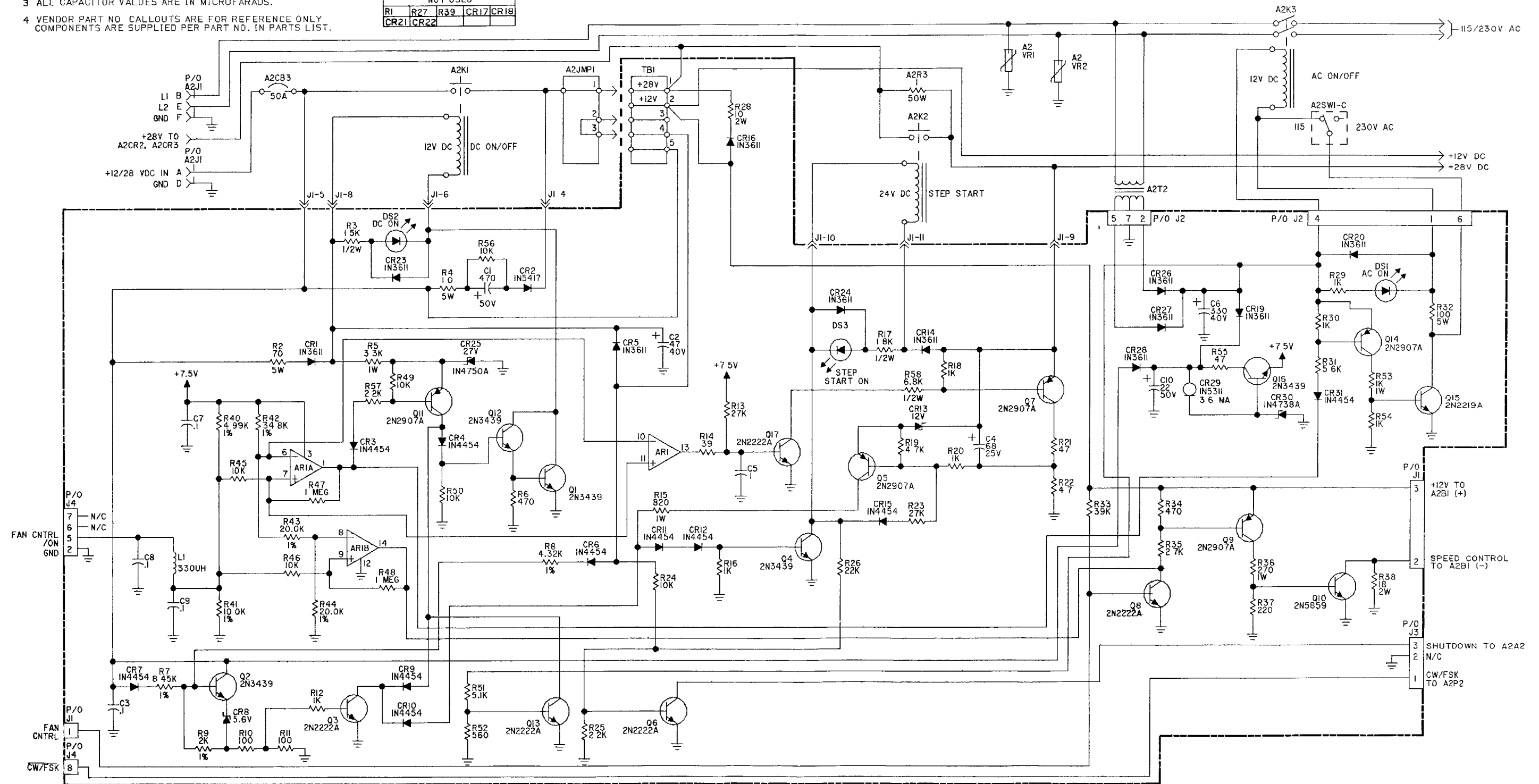

FO-23. POWER SUPPLY PROTECTION AND CONTROL PWB ASSY, A2A1

FP-195/(FP-196 Blank)



NOTE UNLESS OTHERWISE SPECIFIED:

- PARTIAL REFERENCE DESIGNATIONS ARE SHOWN FOR DETAIL PARTS. PREFIX THESE WITH UNIT NO. AND/OR ASSEMBLY DESIGNATIONS SHOWN ON DRAWING TO OBTAIN COMPLETE DESIGNATIONS.
- ALL RESISTOR VALUES ARE IN OHMS. 1/4W. ±5%
- ALL CAPACITOR VALUES ARE IN MICROFARADS (UF).
- ALL INDUCTANCE VALUES ARE IN MILLIHENRIES (MH).
- VENDOR PART NO. CALLOUTS ARE FOR REFERENCE ONLY. COMPONENTS ARE SUPPLIED PER PART NO. IN PARTS LIST
- DC RESISTANCES OF INDUCTIVE ELEMENTS (CHOKES, COILS, MOTOR WINDINGS, ETC.) ARE LESS THAN 1 OHM.
- PANEL DECALS ARE INDICATED BY BOLD TYPE IN A BOLD BOX, E.G. **ON/OFF**.
- ALL RELAYS ARE SHOWN IN THE DE-ENERGIZED STATE.

HIGHEST REFERENCE DESIGNATION	
REFERENCE DESIGNATIONS NOT USED	

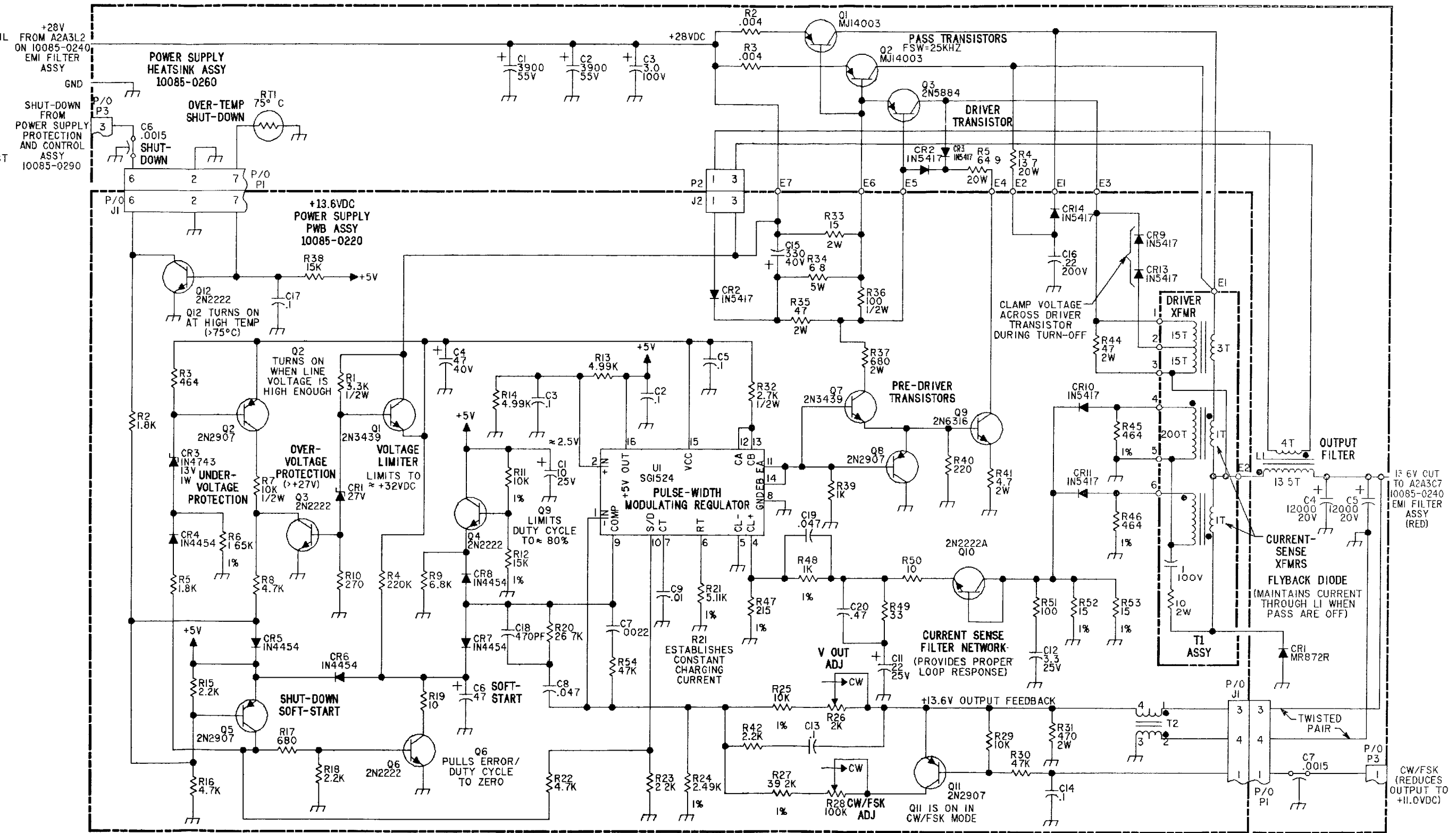

FO-24 13.6V POWER SUPPLY ASSY, A2A2

FP-197/(FP-198 Blank)

